

SPLIT

Concept of the park and memorial





The military dictatorship in Argentina (1976–1983) split society in two. In this situation, one ordinary person became an executioner, while another became a victim. The regime itself divided them, creating a mechanism in which yesterday's neighbor began to torture, and yesterday's friend disappeared forever. Who were they? How did they live before the dictatorship entered their homes? Who were the people who found themselves on opposite sides: those who were kidnapped and those who did the

kidnapping? How did they end up here: by chance, through denunciation, by order, out of conviction? What happened to them within these walls in the clandestine detention center, in the cells, during interrogations, in the «death flights»? How did they leave this place, or did they never leave at all? And what became of them afterwards: were the victims ever able to return to life, and did the executioners ever come to understand what they had done? Our memory is the only protection against this

happening again. This memorial on the site of the «Arsenal,» the former base of the Argentine Army's «Miguel de Azcuénaga» Arsenal Company, where a clandestine detention, torture, and extermination center operated from 1976 to 1978, does more than document crimes. It gives back a voice to those who were meant to be erased. It asks questions of those who would rather forget. Because only by understanding what they felt can we recognize in time the signs of a repeating history.

Concept
Split

1955 marks a turning point: on June 16, military aircraft bombed the Plaza de Mayo in Buenos Aires, where supporters of President Peron had gathered. More than 300 civilians were killed and around 800 wounded.

In September 1955, the military overthrew Peron, and the so-called «Liberation Revolution» came to power.

1973–1975 – Increase in political violence: assassinations of activists, trade unionists, and students.

1975 – Beginning of the «Dirty War»: Operation against guerrillas in Tucuman.

1976–1978 – Peak of repression: 10–30 thousand «disappeared», 340 underground torture centers, «death flights», kidnapping of children (about 500).

1977 – The first marches of the «Mothers of May Square».

1983 - Return of democracy, but without punishment of the guilty.

The fight for justice and memory: Opening museums and memorials at the sites of former torture centers (ESMA – since 2015). Enshrining in national memory the commitment to prevent a repetition of the dictatorship's crimes.



1973–1975 – Crisis: after Peron's death, widow Isabel rules, economic chaos, violence from the left (Montoneros) and right (AAA).

March 24, 1976 - Military coup: overthrow of Isabel Peron.

1976–1978 – The «National Reorganization Process» is established. A network of 340 clandestine centers is created (ESMA is a model). The military develops «death flights,» child abductions, and torture protocols.

1975–1978 – Operation Condor: Coordination of repression between the dictatorships of the Southern Cone.

1981–1982 — frequent changes of military rulers (Videla Viola Galtieri). April–June 1982 — Argentina's defeat in the Falklands War. June 18, 1982 — Galtieri is removed, the regime finally collapses.

1982–1983 — The last junta, led by Bignone, announces elections, destroys evidence of crimes, and passes a law granting self-amnesty to the military. December 10, 1983 — The dictatorship falls, and power is transferred to a civilian government.

1986–1990 – Amnesty and pardon laws (Alfonso, then Menem). Trial of the juntas, first verdicts for victims of justice. 2005 – Amnesties rescinded, military trials resumed.

Memorial concept
Visualisation



Masterplan

Full diagram

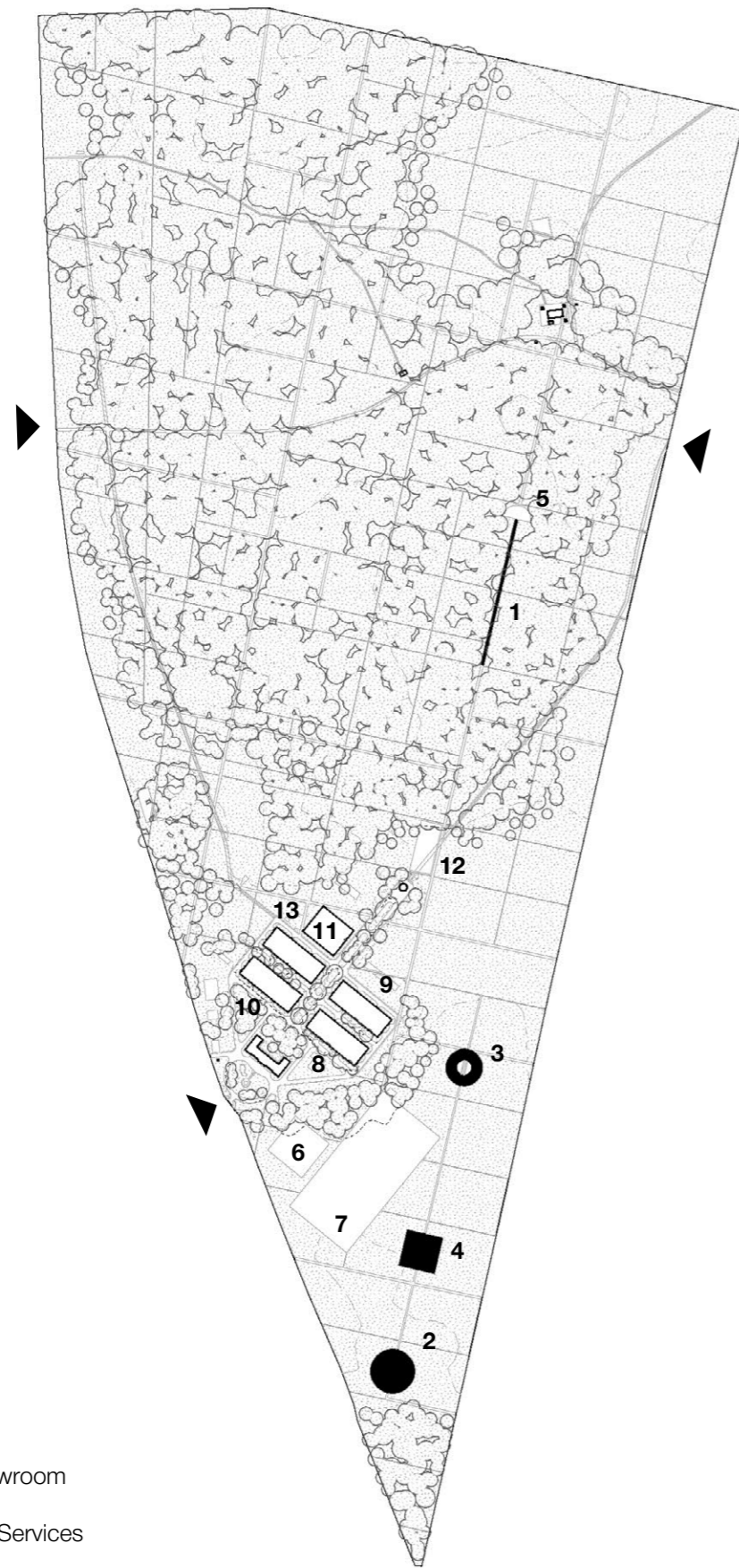

Legend

- 1 - Memorial
- 2 - Concert/Recital Hall
- 3 - Classroom Complex
- 4 - Conference Room Complex
- 5 - Amphitheater
- 6 - Parking A
- 7 - Parking B
- 8 - Administration
- 9 - Historical Exhibition Pavilion
- 10 - Memorial Art Gallery
- 11 - Immersive Audiovisual Showroom
- 12 - Memory Plaza
- 13 - Commercial Premises and Services

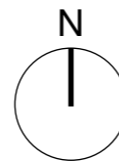
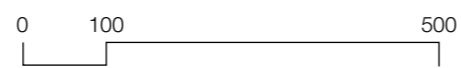

Context paths and buildings

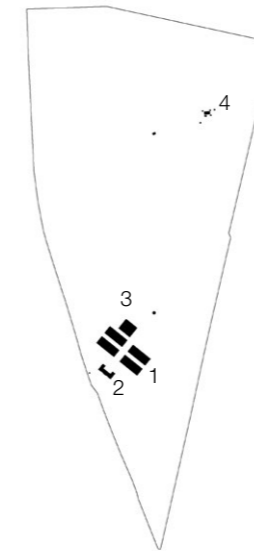

- 1 - Barracks
- 2 - Administration
- 3 - Warehouse
- 4 - Warehouse 9

Terrain

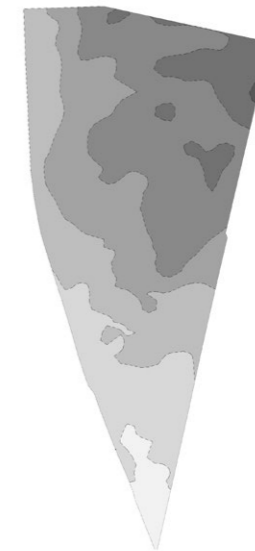

- the highest level
- the lowest level

Vegetations



- Current vegetations

New interventions

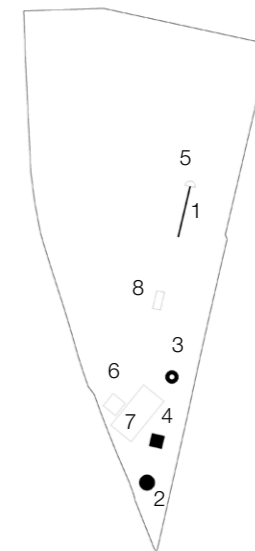

- 1 - Memorial
- 2 - Concert/Recital Hall
- 3 - Classroom Complex
- 4 - Conference Complex
- 5 - Amphitheater
- 6 - Parking A
- 7 - Parking B
- 8 - Memory Plaza

Landscape yards

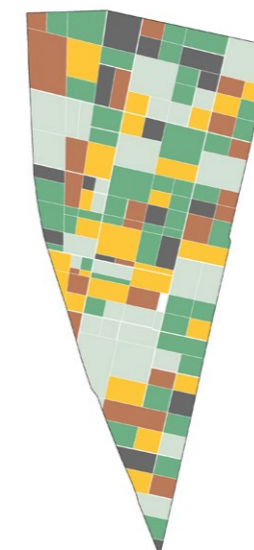

- Yards

Functional zones

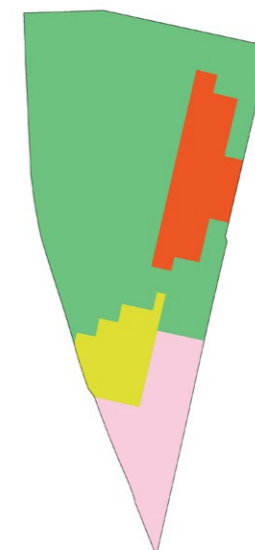

- Park
- Interpretation center
- Complement
- Memorial

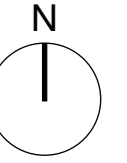

A
Context

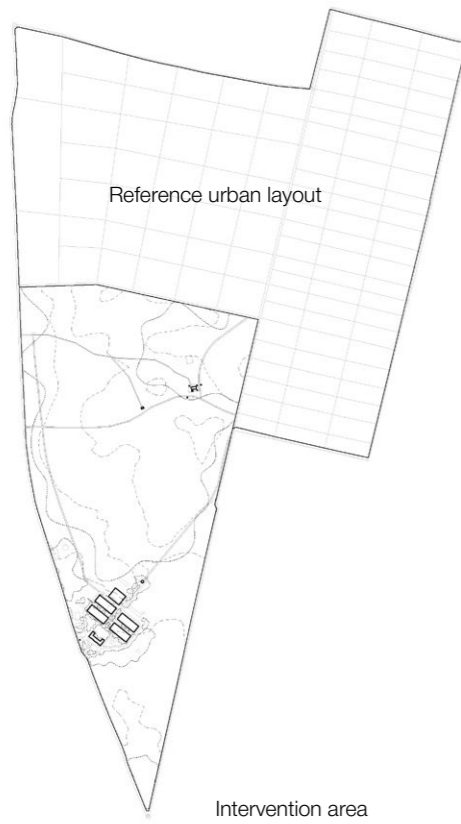

In developing the concept for territorial planning, much attention was paid to the provided urban context.

B
Landscape grid

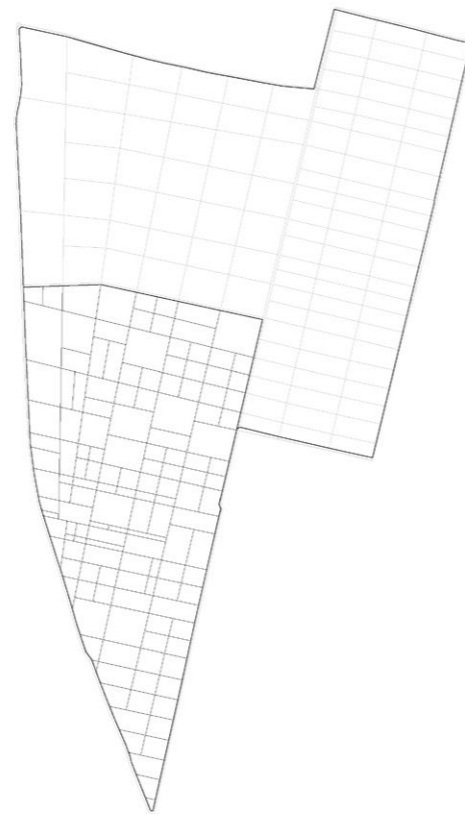

We propose to mentally extend the existing urban grid into the park area, thereby linking the park with the city at the planning and semantic levels.

C
Landscape yards

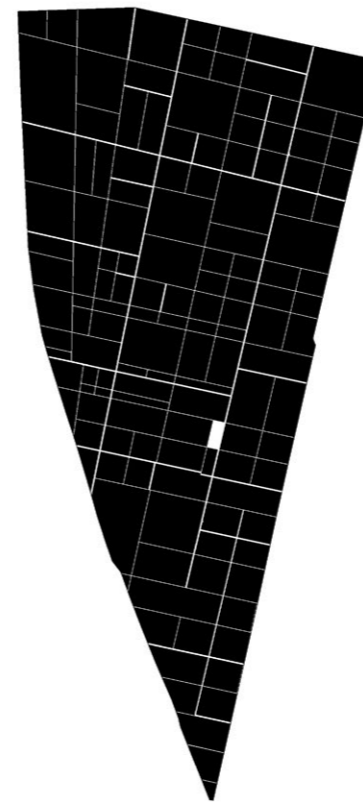

The resulting network of roads, paths and architecture forms a space of diverse gardens.

D
Context + Landscape yards



This structure of gardens symbolizes the history of the Argentine state, where the events raised in the memorial occupy only one period of time, but nevertheless influence the whole history.

Memorial concept
Visualisation



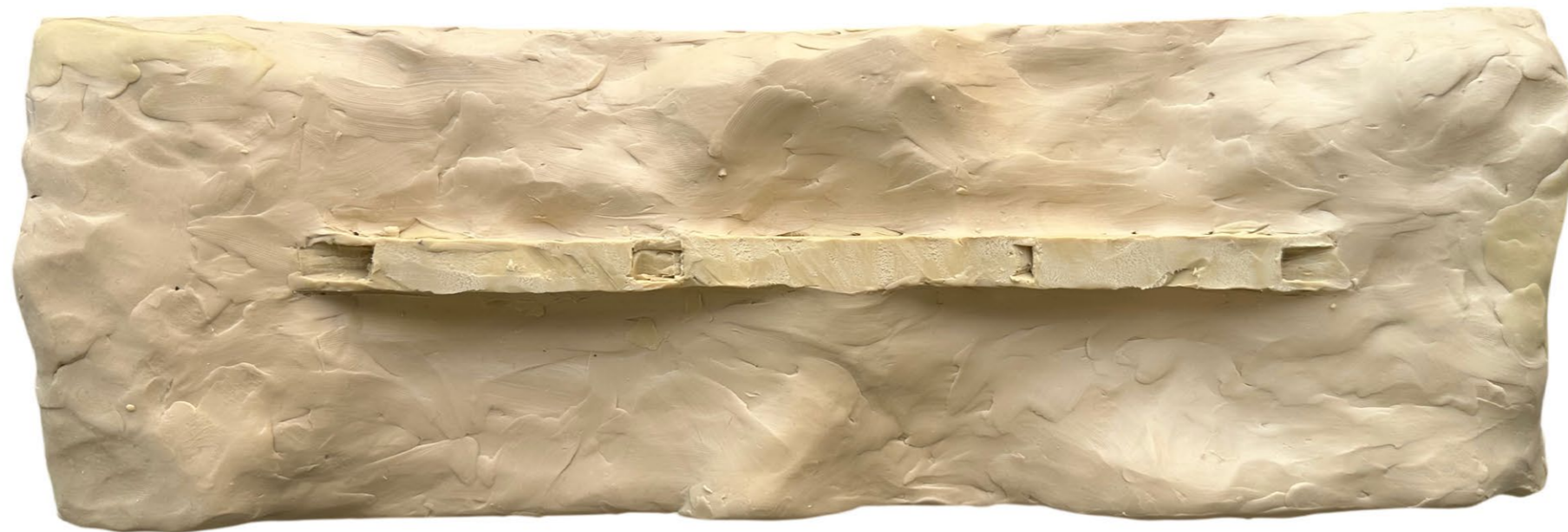
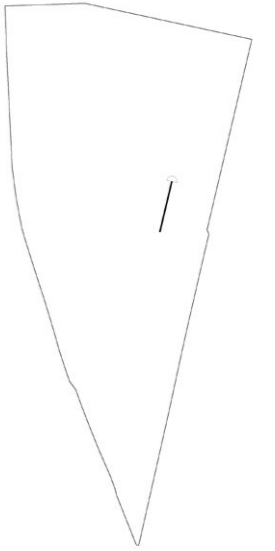

As previously stated, the planning structure of the park within the design area replicates the urban fabric of its surroundings. The lines of this grid embody all the lines of Argentina's state history. The memorial, in this context, represents one of the threads of this rich history. We would like to emphasize both the finite nature of the hot phase of this social conflict and its impact on the entire historical trajectory of Argentina. This is how the structure of the memorial

itself took shape: an elongated line in plan, sinking into the existing topography of the site. The length of this memorial line symbolically coincides with the duration of the political regime. Thus, the memorial actively interacts with the park's terrain. At times it rises openly to the surface, while at others it completely conceals itself within the thickness of the earth, allowing a visitor to walk past without noticing anything out of the ordinary.

The memorial has one main entrance and one main exit at the two ends of the line. There are also additional entry and exit points along its length, allowing visitors to leave the exhibition early. The exterior architecture is modernistically ascetic and minimalist, which discourages any external observer from drawing conclusions about the site's history.

Memorial concept

Narrative

Despite the external simplicity of the memorial, its internal composition is far more complex and multifaceted, much like the history it addresses.

The narrative here is divided according to the stages outlined in the exhibition scenario. At the same time, the duality of the historical perspective on this incident is preserved. The entire story is told in a linear and chronological sequence.

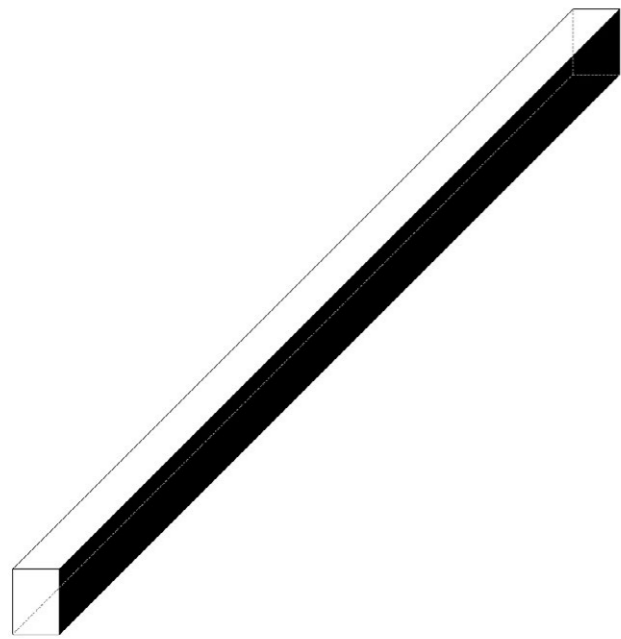
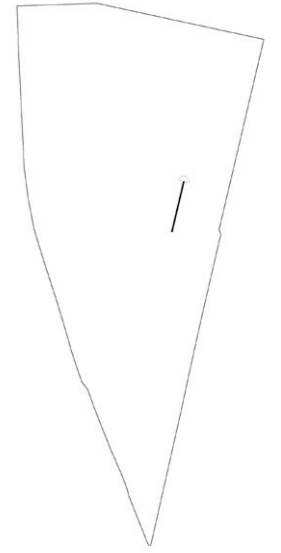

1. FORM - line

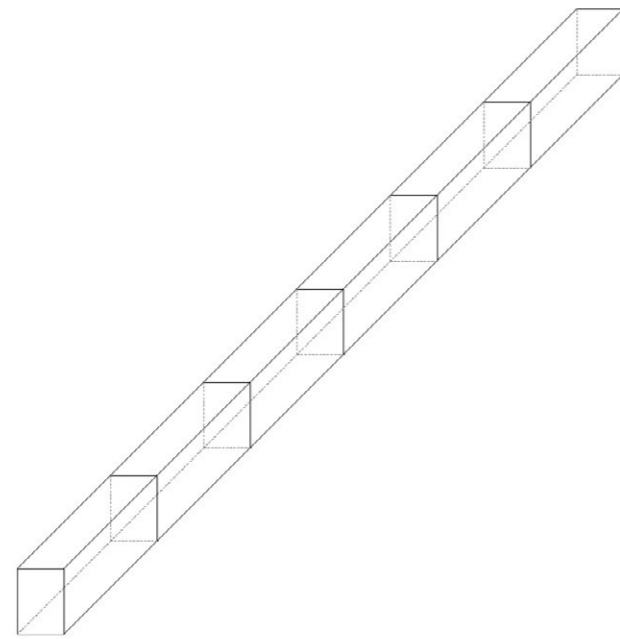

2. NARRATIVE - stages

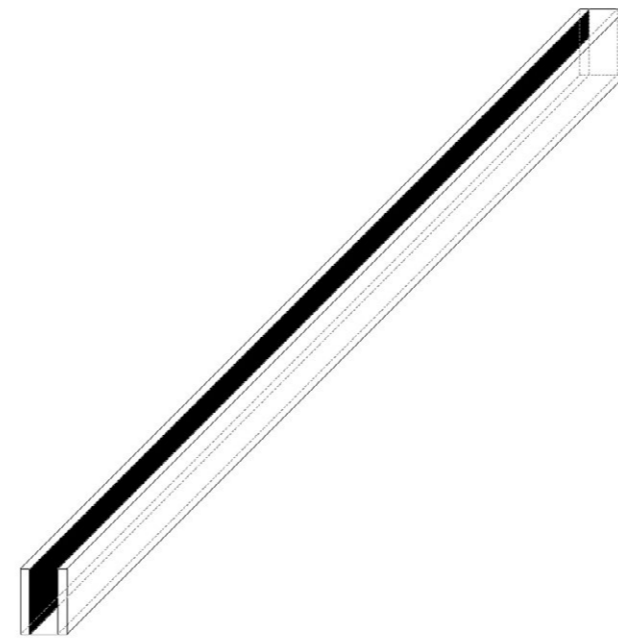

3. NARRATIVE - duality

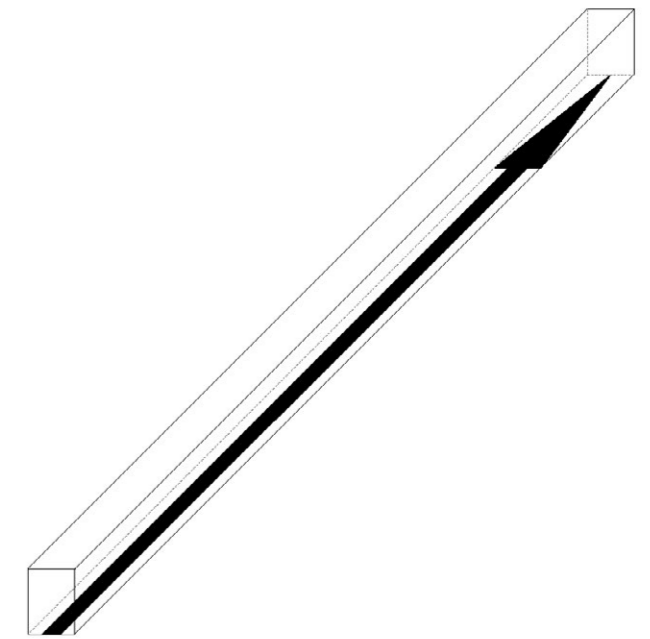

4. NARRATIVE - linearity

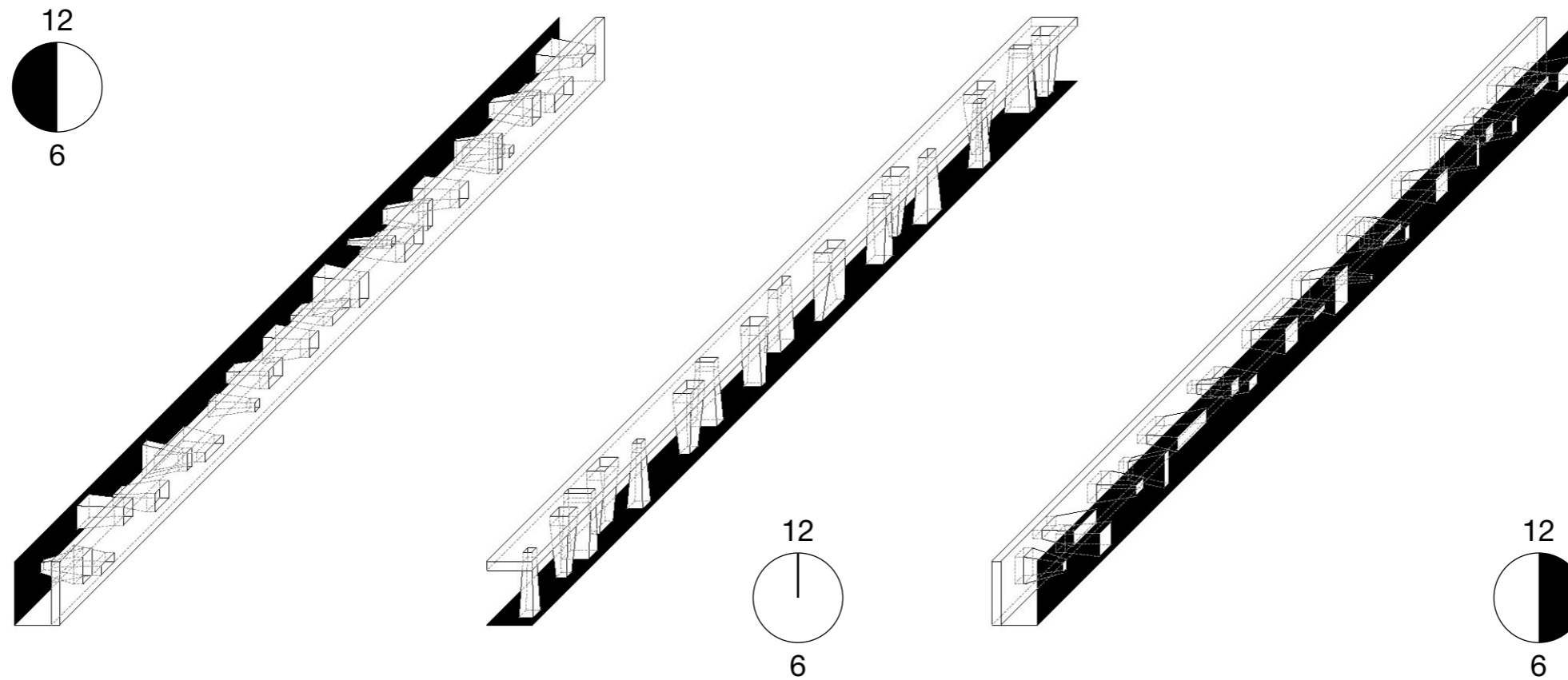

An important, or perhaps the most important, element shaping the architecture of the memorial's interior space is natural light. The orientation of the memorial in space almost aligns with the north-south axis. The exhibition, enclosed within the memorial's interior structure, unfolds gradually over time, following the movement of the sun across the sky throughout the day.

During the first half of the day, from dawn to noon, the sunlight illuminates the perspective of the suffering rebels and opponents of the regime. During the second half of the day, from noon to sunset, we see the opposite perspective on the incident, that of the supporters of the regime that controlled Argentina during that period.

At noon, we can observe the entire historical perspective in full, from both sides, when the shadows cast by the sunlight illuminate both sides of the exhibition through the upper skylights. In this way, we wanted to emphasize the duality of the historical context, allowing each visitor to draw their own conclusions.

Memorial concept

Amphitheater

The journey through the memorial exhibition concludes at an amphitheater located near the former detention site of political prisoners. In our view, the amphitheater should become a place of public discussion about the history of the state, including the discussion of this historical incident.



Memorial concept

Structure

Legend

- 1 - Human and rights
- 2 - Supervision
- 3 - Flight of death
- 4 - NN graves

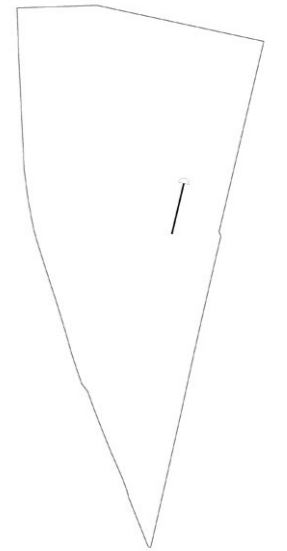
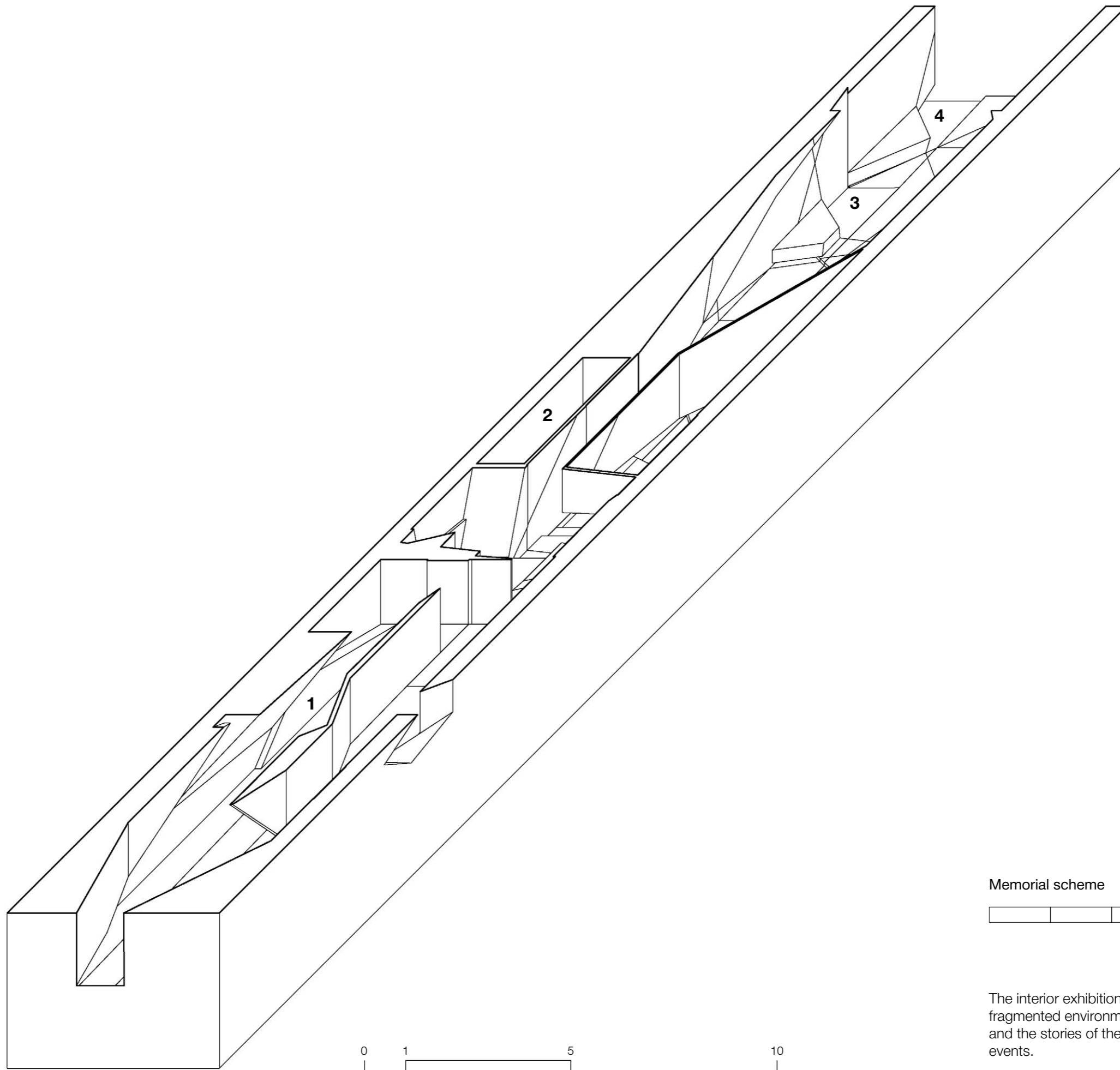

Memorial scheme



The interior exhibition space of the memorial is a complex, fragmented environment that holds the historical meanings and the stories of the people who survived the horrific events.



Memorial concept

Structure

Legend

- 1 - Human and rights
- 2 - Supervision
- 3 - Flight of death
- 4 - NN graves

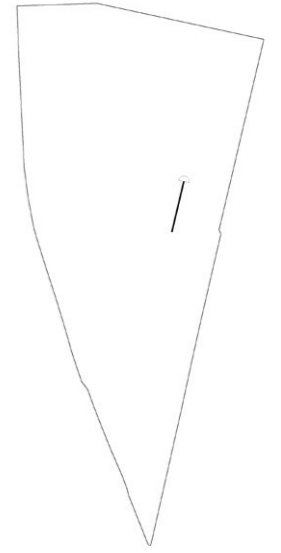
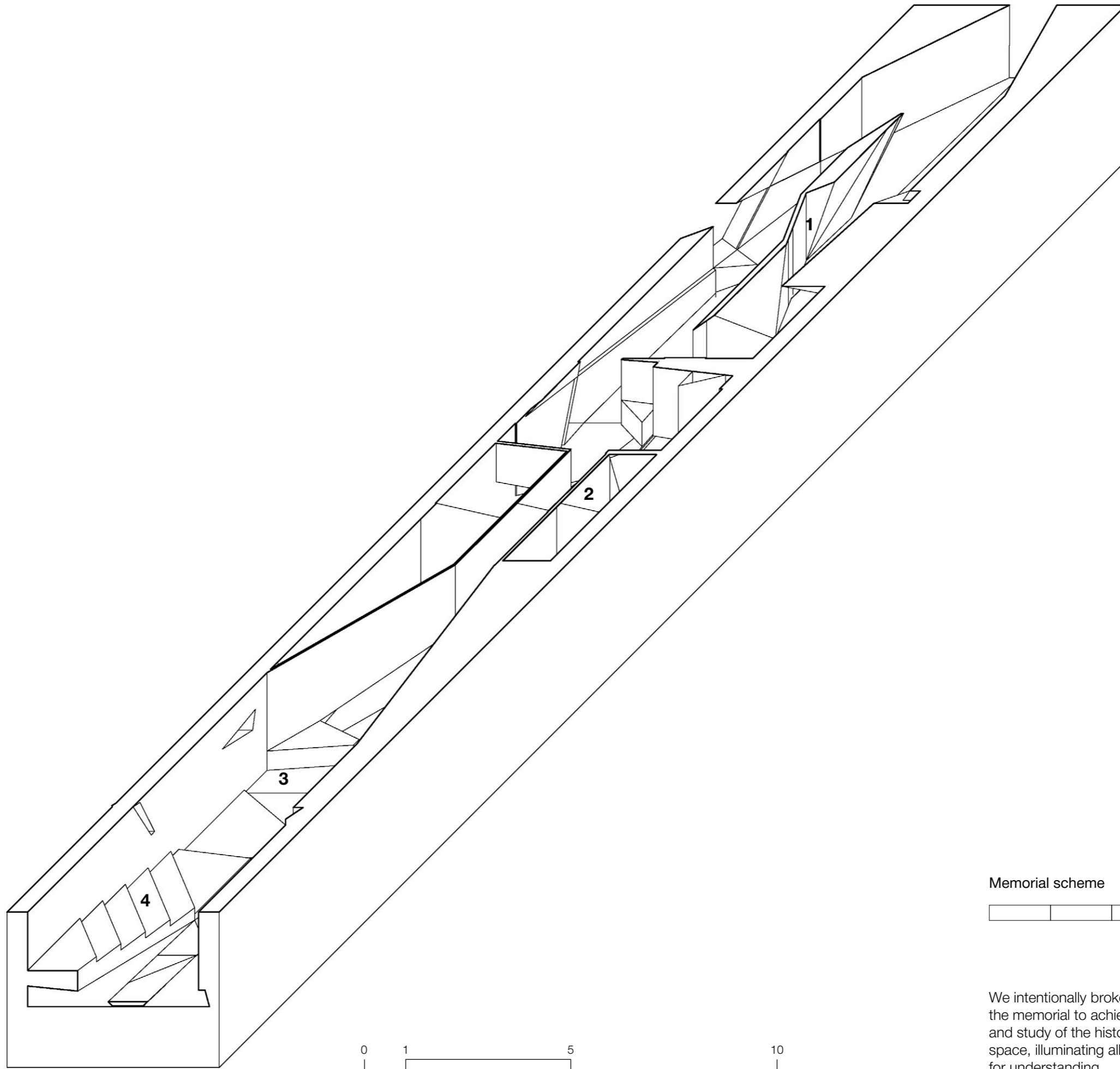

Memorial scheme



We intentionally broke, bent, and deformed the space of the memorial to achieve the best possible immersion in and study of the history. Natural sunlight complements this space, illuminating all the elements and details necessary for understanding.

Memorial concept

Section

Legend

- 1 - NN graves
- 2 - Flight of death
- 3 - Amphitheater The hope
- 4 - Vargas Well
- 5 - Human and rights

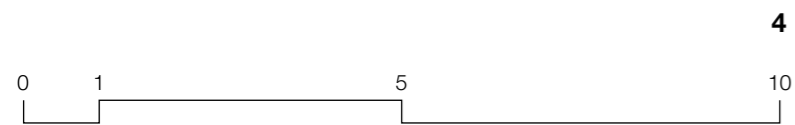
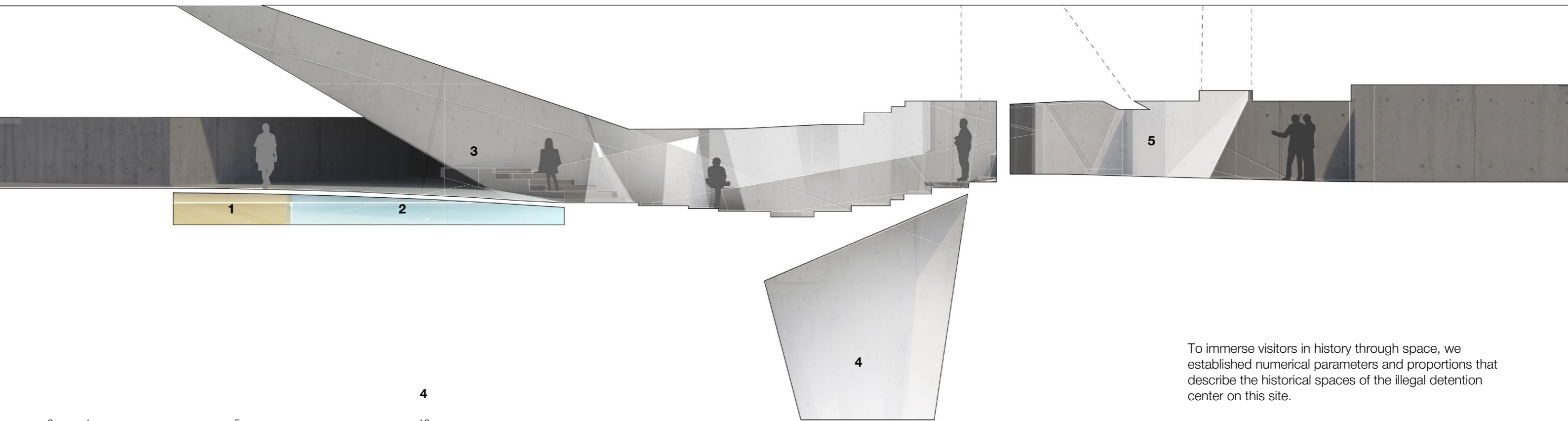
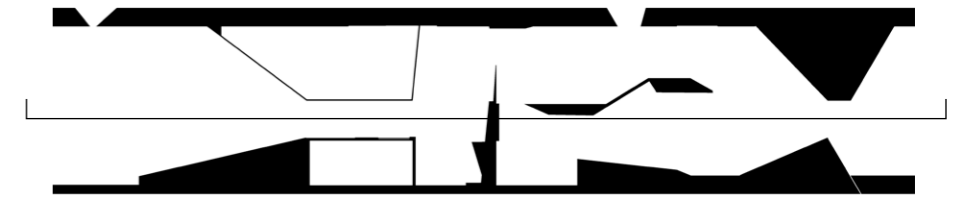

Memorial scheme



To immerse visitors in history through space, we established numerical parameters and proportions that describe the historical spaces of the illegal detention center on this site.

For example, part of the exhibition is formed by a 1.1-meter-wide passageway, corresponding to the width of the small, stuffy rooms where prisoners were held.

The ceiling height averages 2.5 meters, corresponding to the height of the fence surrounding the closed detention area.



Memorial concept

Plan

Legend

- 1 - The way «To be human»
- 2 - Human and rights
- 3 - Supervision
- 4 - Vargas Well
- 5 - Amphitheater «The hope»



Memorial scheme



Arsenal Memory Park

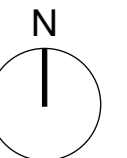
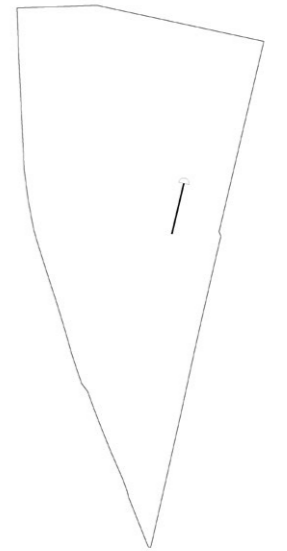

We sought to compose the memorial exhibition using only architectural methods and means, avoiding as much as possible any graphic information, which is already abundant everywhere in our time. Instead, we wanted visitors to the memorial to partially experience and live through this resonant historical event on a sensory and emotional level of perception as they walk through the exhibition.



Interpretation center

Objects

In addition to the main memorial exhibition, three interpretation center objects have been developed on the territory of the «Arsenal» complex, each with its own function, architecture, and symbolic meaning. Together, they form a space where memory is not only preserved but also lived through, reflected upon, and passed on.

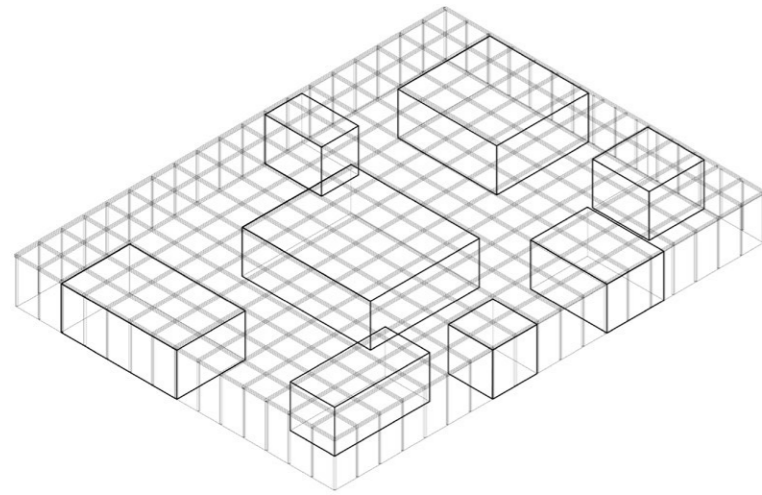

Conference Room Complex

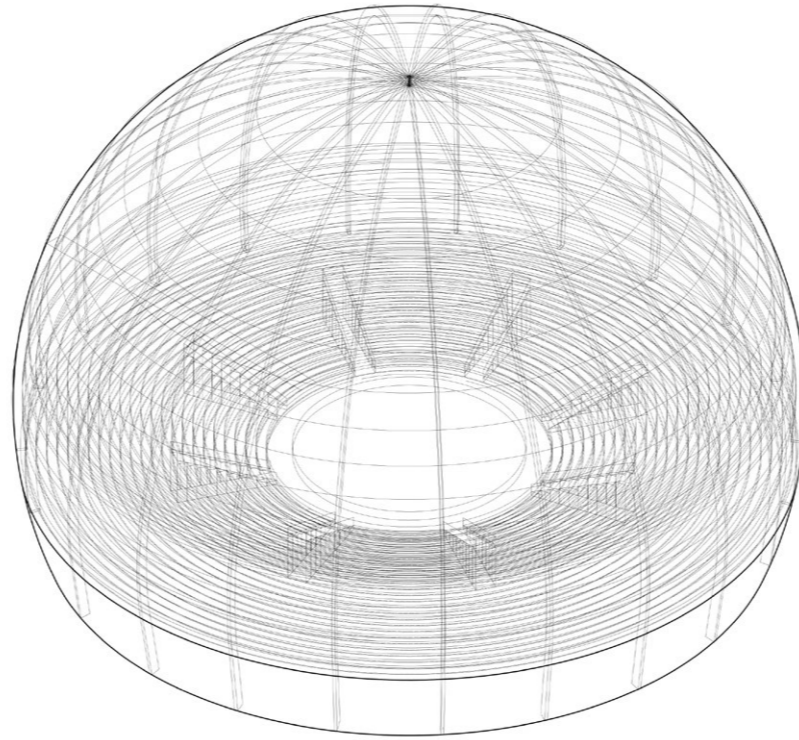

Concert/Recital Hall

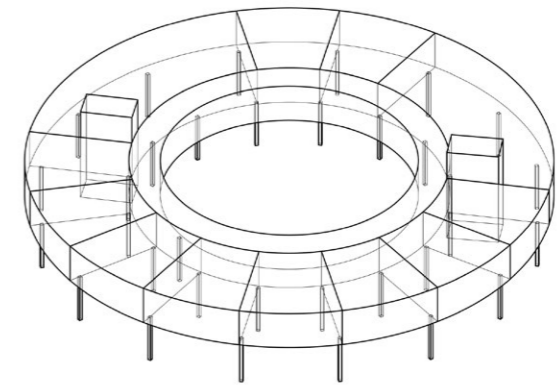

Classroom Complex

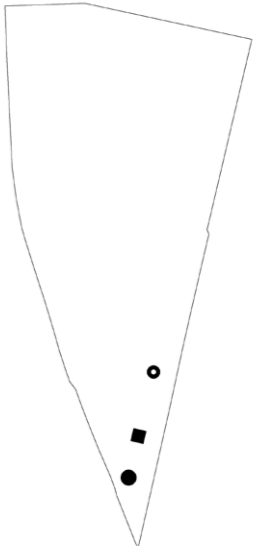

Memorial concept
Concert/Recital Hall

Collage outside



Collage inside

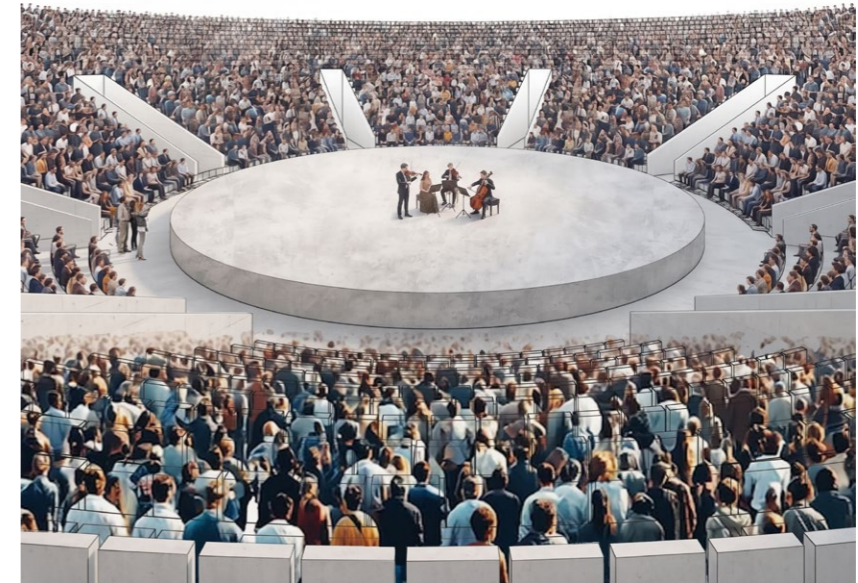

Description

The spherical auditorium of the memorial complex symbolizes the unity of a divided society and the fragility of memory, which must be constantly protected. Its closed, perfect form reminds us that history tends to close itself in a circle of repetition, and only a conscious effort of memory can break this circle.

This high-tech hall, with a capacity of 8,000 people, is designed for a variety of immersive and interactive audiovisual performances. Concerts, theater productions, documentary projects, and multimedia installations take place here, immersing the audience in the experience of the past through sound, light, and image. The space of the hall allows visitors not only to listen and watch but also to feel: what the victims felt and what the perpetrators chose to forget.

The hall becomes not a place of entertainment but a space of testimony, where music, voices, and images return memory to those who were meant to be erased and pose questions to those who would rather forget.

Structure

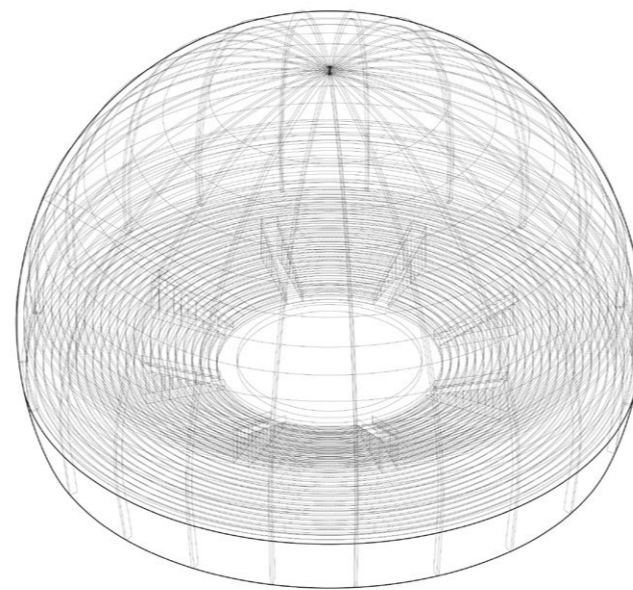

Functional diagram

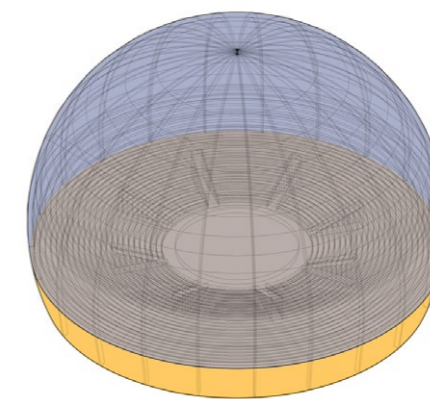

■ hall
■ lobby



Memorial concept

Classroom Complex

Collage outside



Description

The multifunctional academic complex of the memorial is designed for educational activities and seminars. It includes classrooms, a physical and digital library, as well as administrative and service areas, covering approximately 1500 square meters. The building has a circular shape with a courtyard atrium in the center and is raised above the ground on supports. The circle symbolizes the continuity of memory, which must be passed from generation to generation so that history does not repeat itself. The open courtyard at the center becomes the heart of the complex: a place for meeting, dialogue, and collective reflection. Being raised on supports creates a feeling of lightness and transparency, in contrast to the heaviness, oppression, and isolation experienced by the prisoners here. The complex seems to float above the ground, not erasing the memory of the past but allowing us to look forward.

Structure

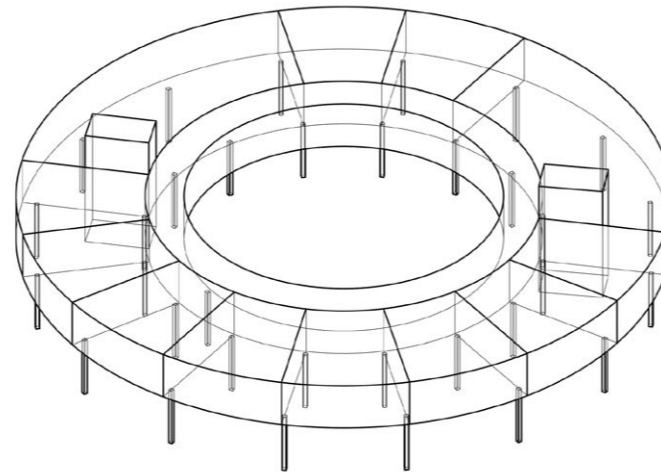

Functional diagram

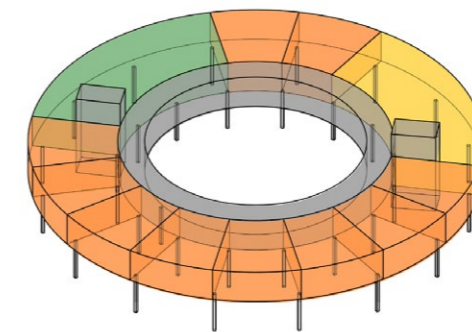

■ classroom ■ connections
■ library ■ lecture hall

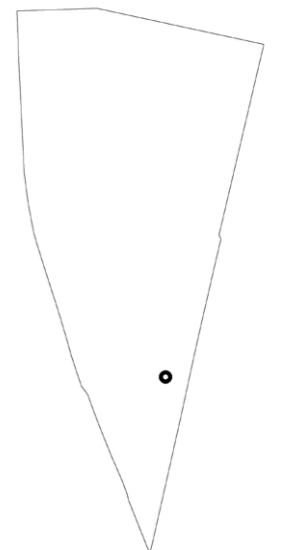

Memorial concept
Conference Room Complex

Collage inside



Description

The memorial's conference center is designed for lectures, congresses, exhibitions, and other public events. It includes conference rooms of varying capacities, administrative offices, and service areas, covering approximately 2500 square meters.

The architectural structure of the center is based on the «volume within a volume» principle. Inside a single large external volume, halls of different sizes are dispersed, with open space organized between them for communication, meetings, and dialogue. This composition symbolizes the multiplicity of voices within a single, shared space of memory.

The center becomes a platform for intellectual and emotional exchange. Scholars present research, witnesses share testimonies, artists display exhibitions, and public figures discuss how to prevent the repetition of tragedy. This is a space of living dialogue between past and present, between memory and oblivion.

Structure

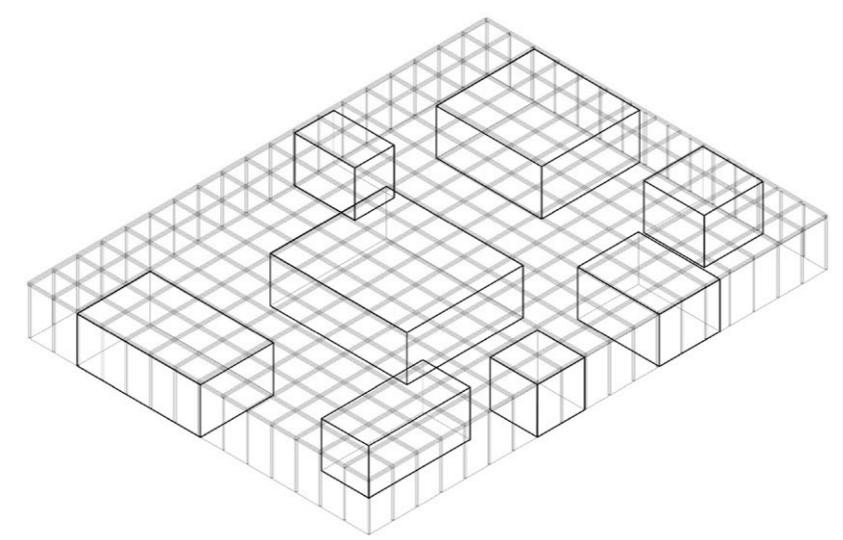

Functional diagram

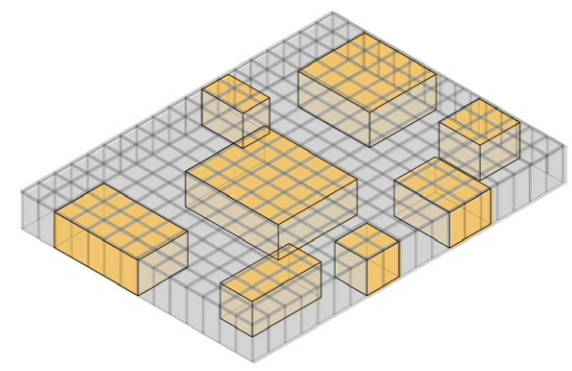

Grey Foyer
Yellow Conference room

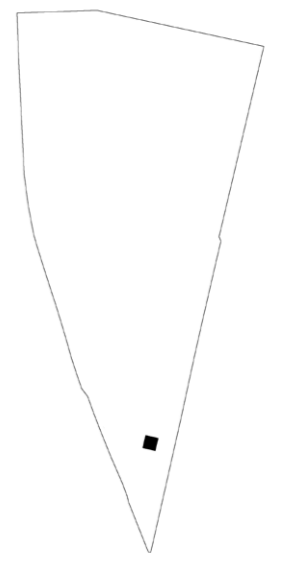

Team

Team members



Ilnar Akhtiamov / Rezeda Akhtiamova

Professors / Tutors
TIArch Studio / Kazan State University
of Architecture and Engineering



Vladimir Obrosov

MArch 2nd year
TIArch Studio / Kazan State University
of Architecture and Engineering



Danil Nazarov

MArch 1st year
TIArch Studio / Kazan State University
of Architecture and Engineering



Kseniia Krepkogorskaia

MArch 1st year
TIArch Studio / Kazan State University
of Architecture and Engineering



Radmir Valeev

BArch 5th year
TIArch Studio / Kazan State University
of Architecture and Engineering



Anastasia Sergeeva

BArch 1st year
TIArch Studio / Kazan State University
of Architecture and Engineering

