

*The Void*



To better understand the severity of this tragedy, we turned to history and examined the attitude towards it from different points of view



## «The whole path of tragedy» Central installation

We have shifted the story to a central installation. The starting point is a stone on which shaky stones are placed, reflecting anxiety and instability in society. At the breaking point, there is a split between those who are still alive and those who have left. The end point is also a stone. Another form. Below.

Society is always in decline after crises. But could grow.

There is an opportunity to go downstairs and feel the instability and threat hanging over you

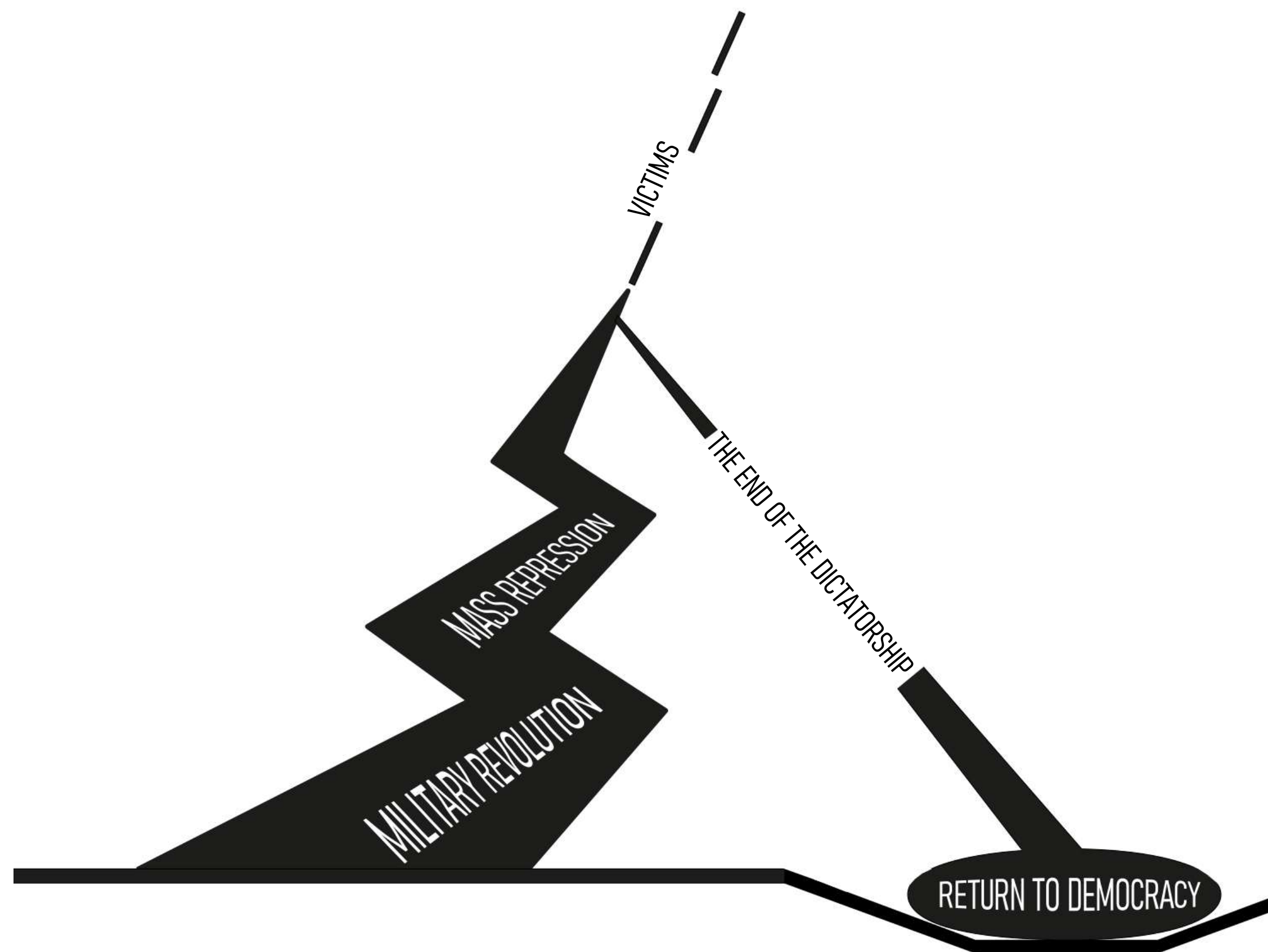

**«The whole path of tragedy»  
Central installation**

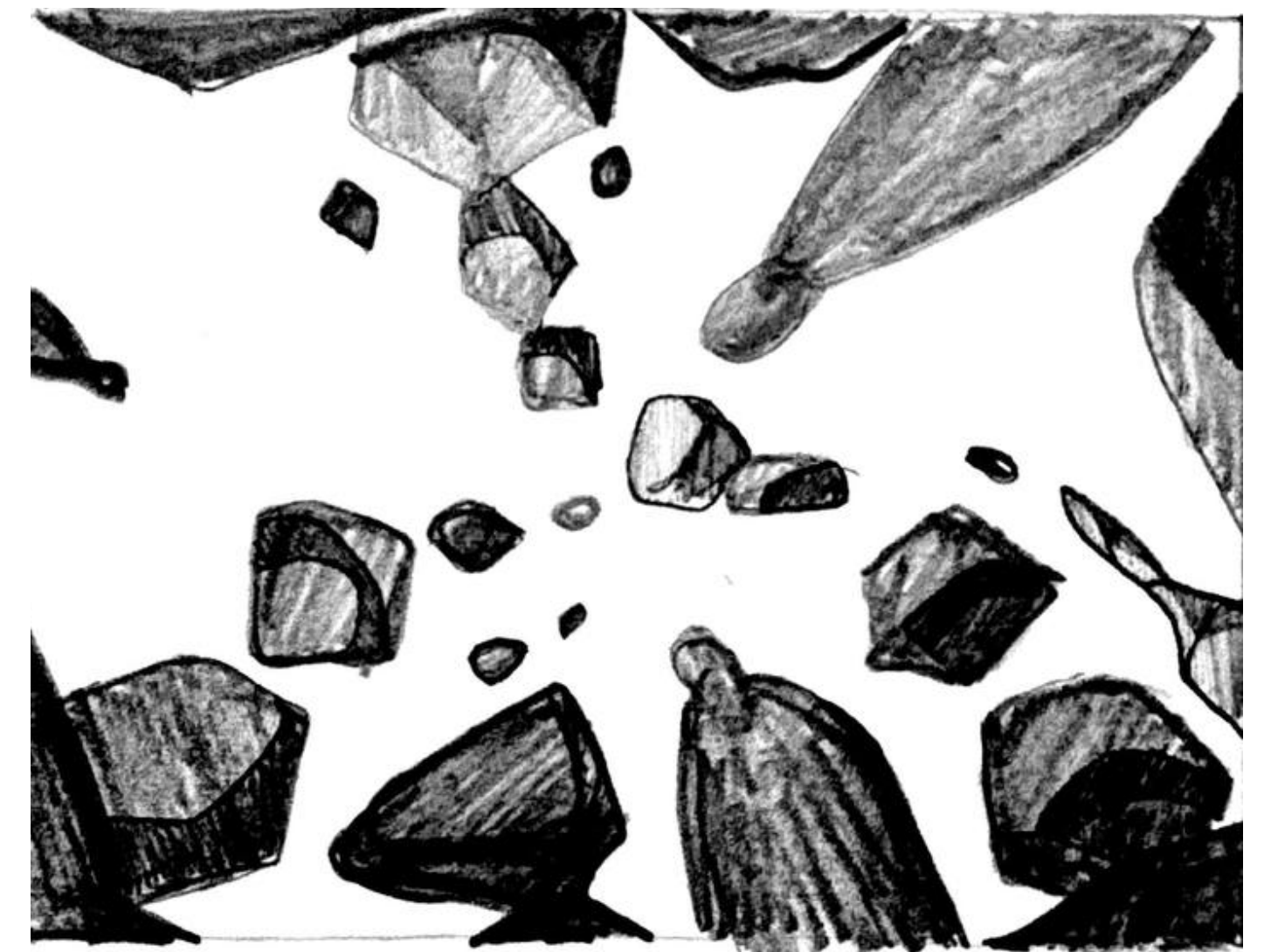
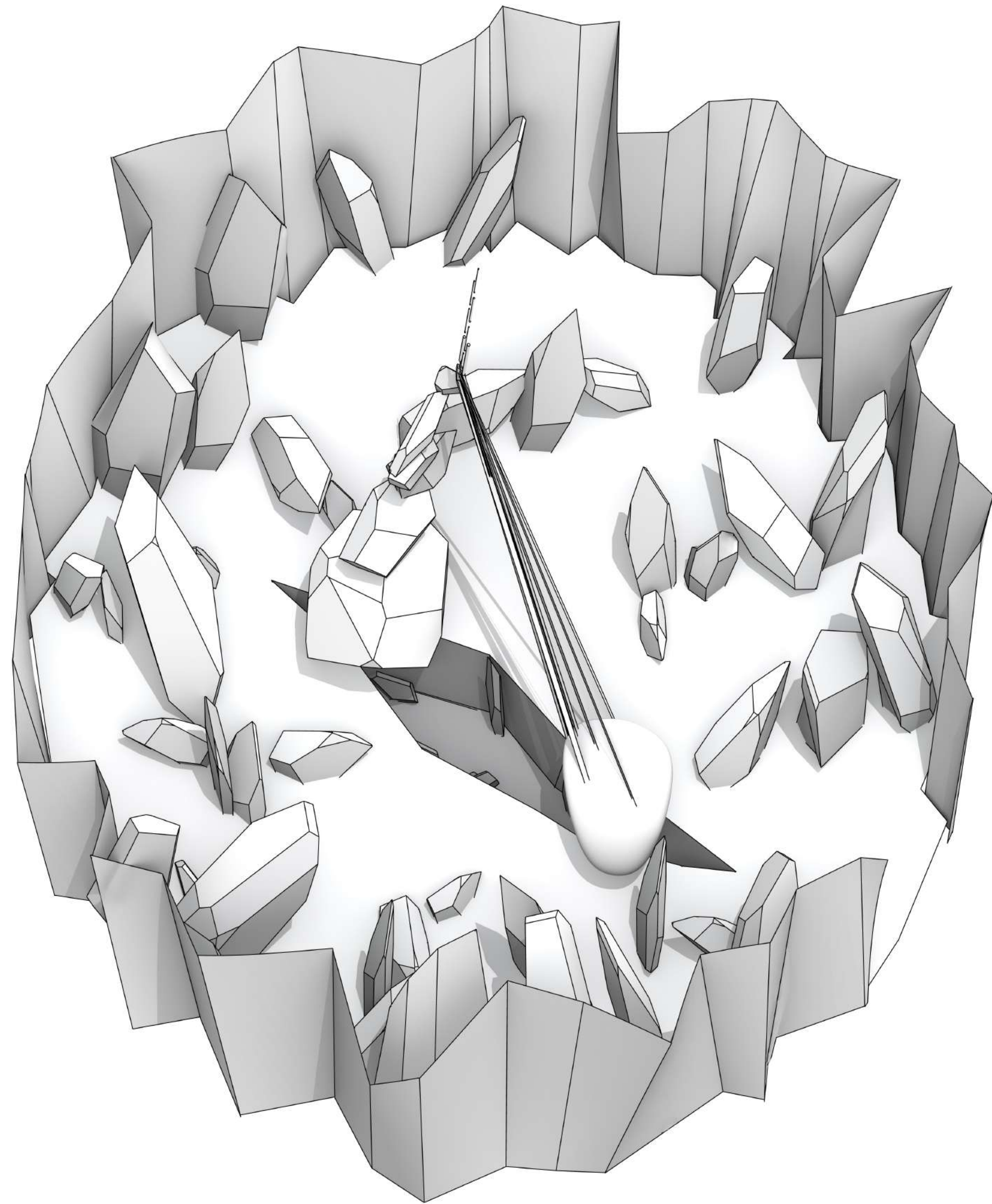

Master Plan

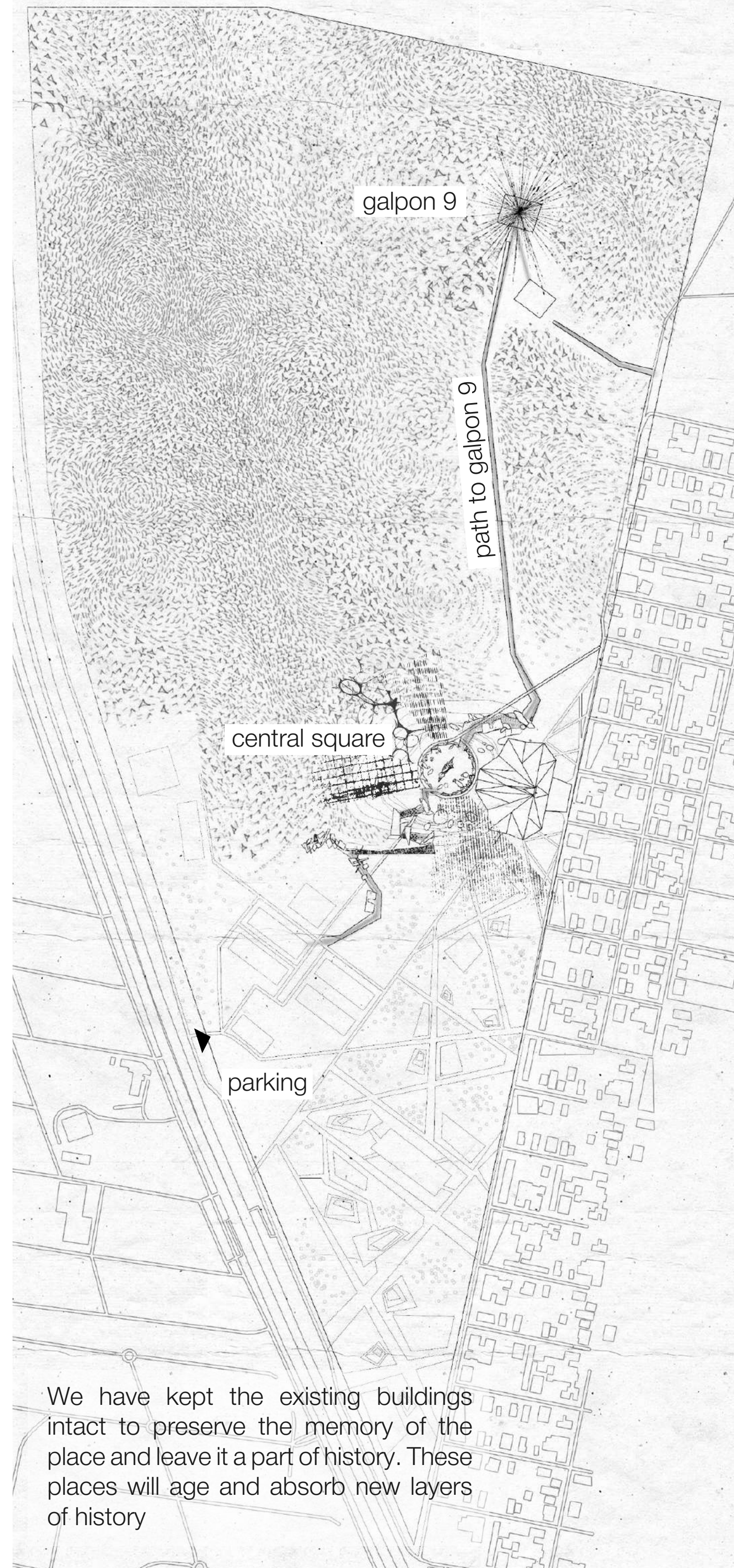

We have kept the existing buildings intact to preserve the memory of the place and leave it a part of history. These places will age and absorb new layers of history

Plan

The main square contains the main spaces necessary for the functioning of the memorial complex

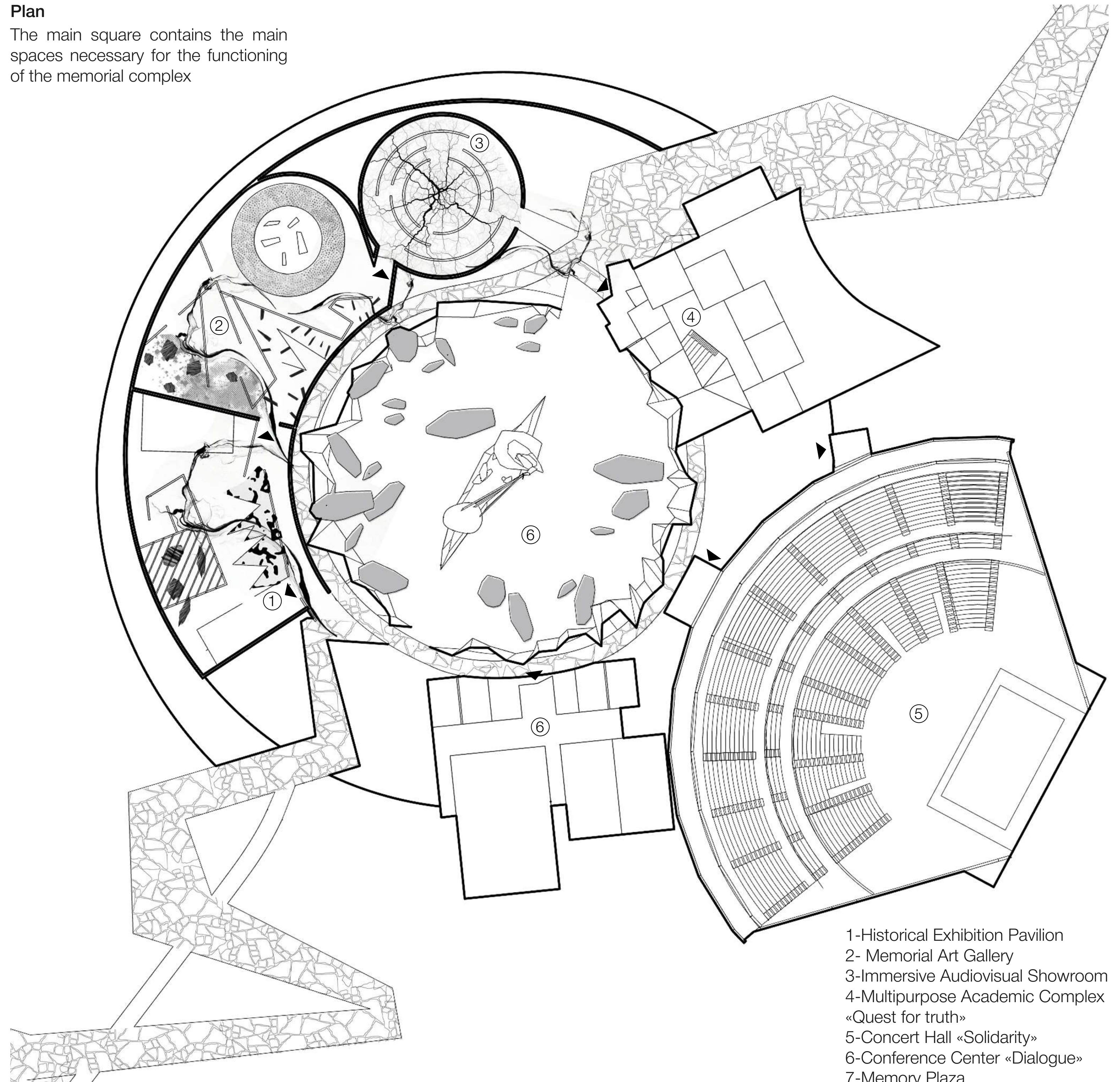

- 1-Historical Exhibition Pavilion
- 2- Memorial Art Gallery
- 3-Immersive Audiovisual Showroom
- 4-Multipurpose Academic Complex «Quest for truth»
- 5-Concert Hall «Solidarity»
- 6-Conference Center «Dialogue»
- 7-Memory Plaza

The matrix of reliefs

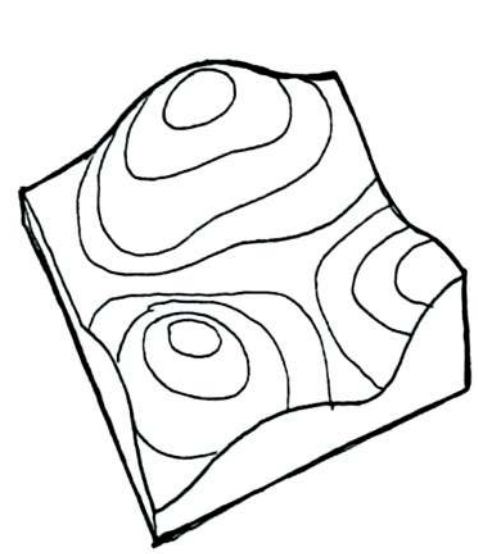

landscape

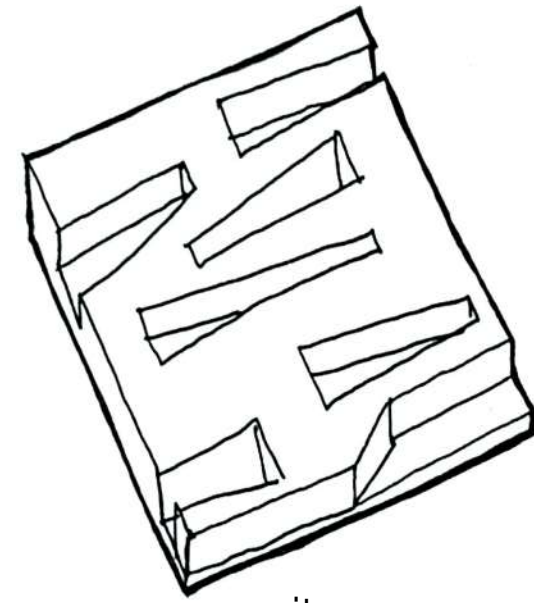

cavity

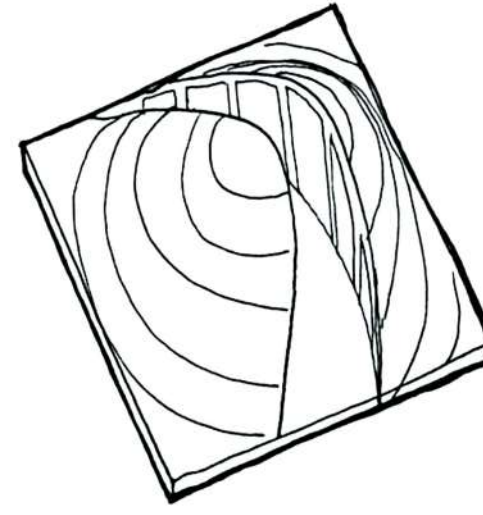

crevices

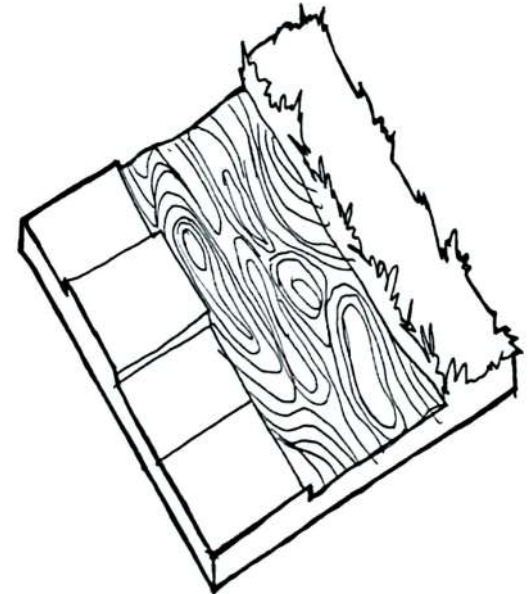

water

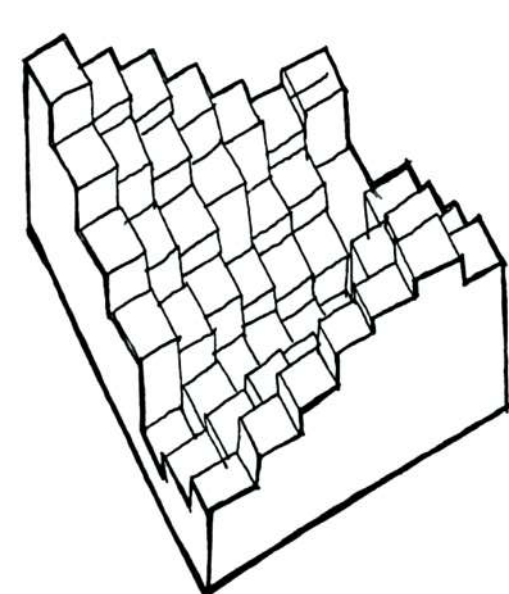

artificial relief

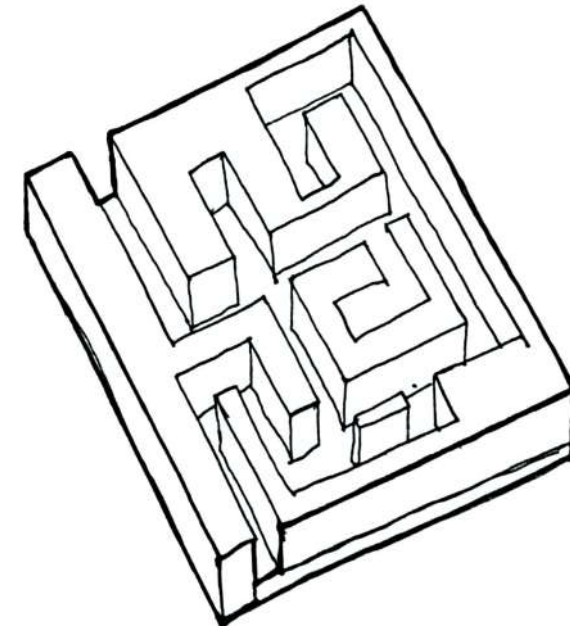

maze

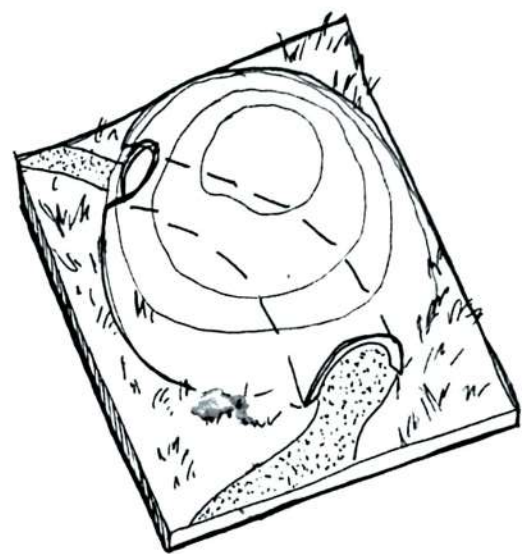

tunnels

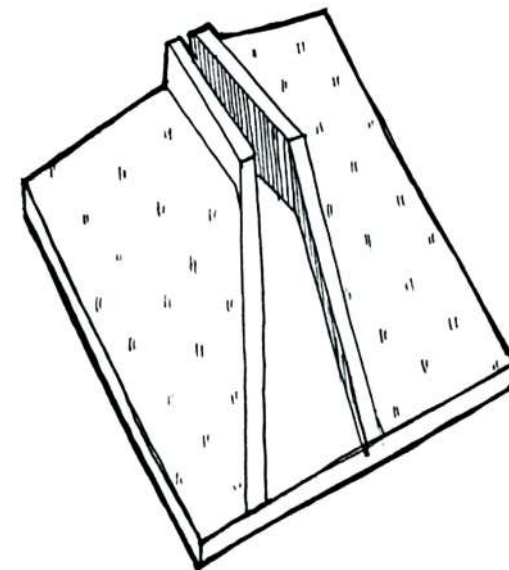

constrictions

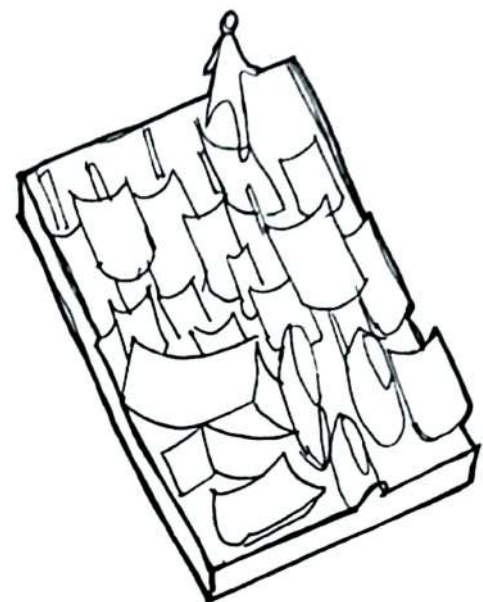

kinetic relief

The matrix of installations



sounds

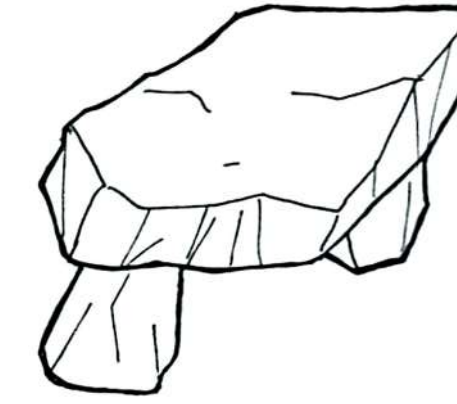

megaliths

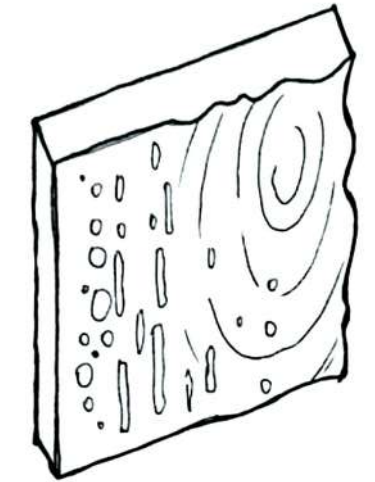

tactile

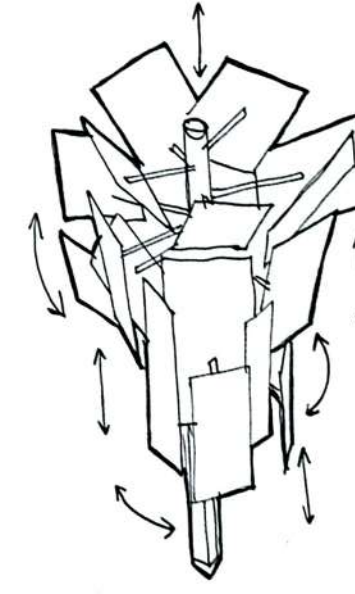

universals

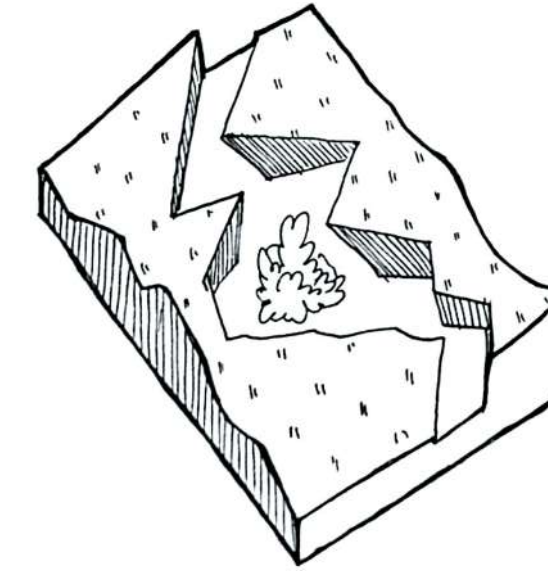

contrasts

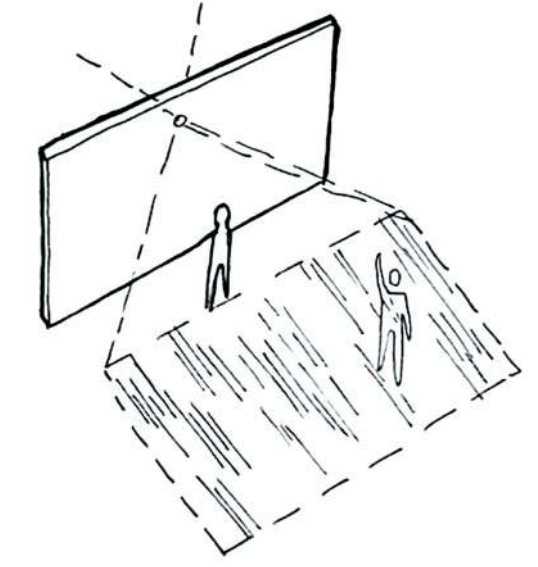

projections

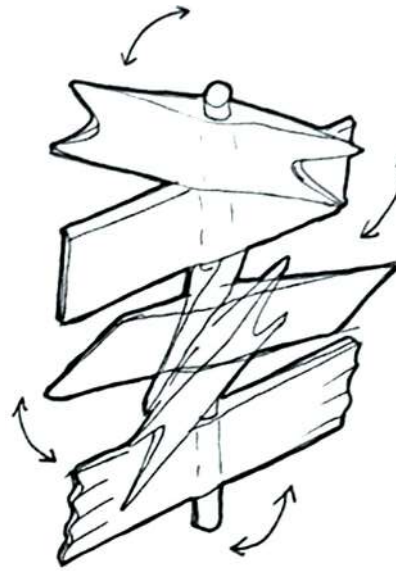

informations

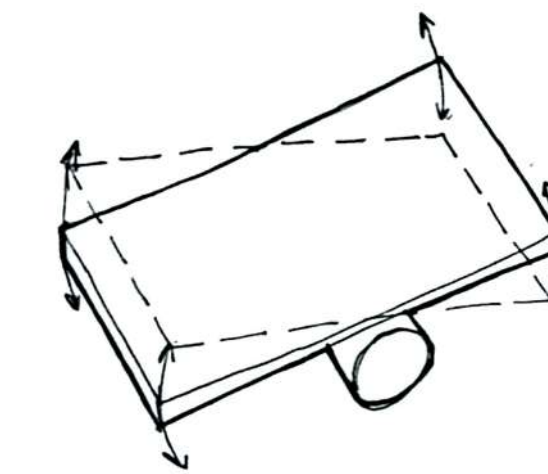

dynamics

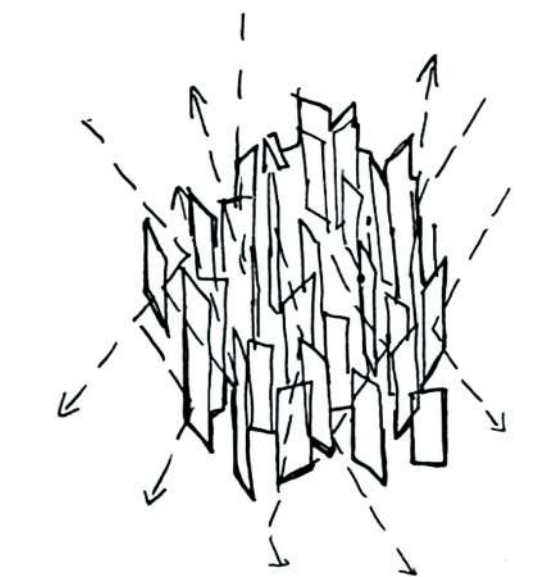

lights

We use various techniques to engage all the senses and influence the conscious and unconscious

## Path to the main square

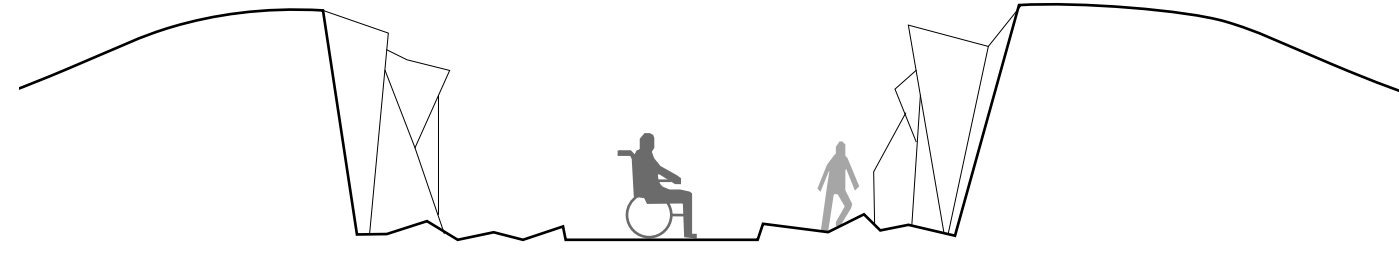

The path to the main square is not an easy one. It is covered with uneven paving stones. Rough stone walls along the borders of the passage create an atmosphere of tension. A flat path in the middle is provided for the movement of people with limited mobility. Along the way, you will encounter stones symbolizing non-victims found, sometimes faceless and unidentified.

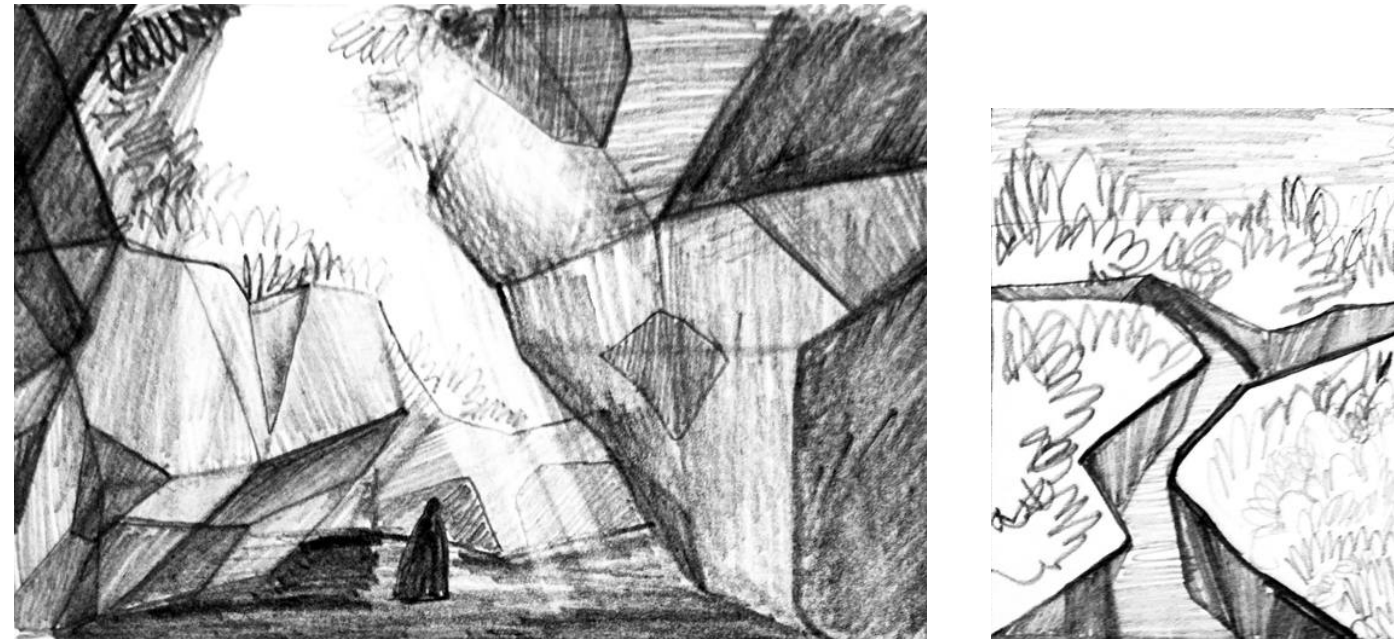

# «The Spiral» General scheme and route

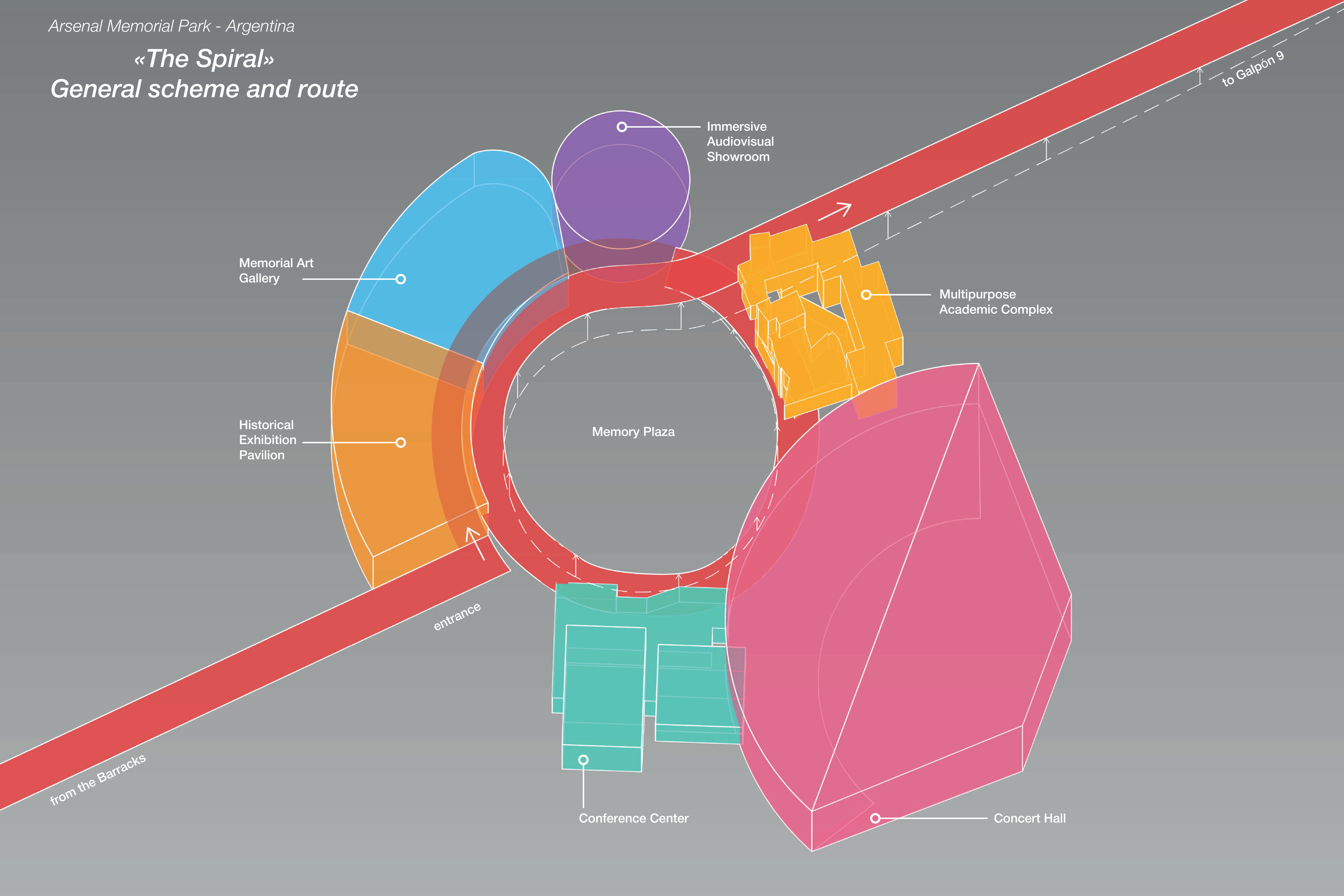

# «The healing wound» Central Square

The contrast of nature and the «ashes» shows how violence destroys everything

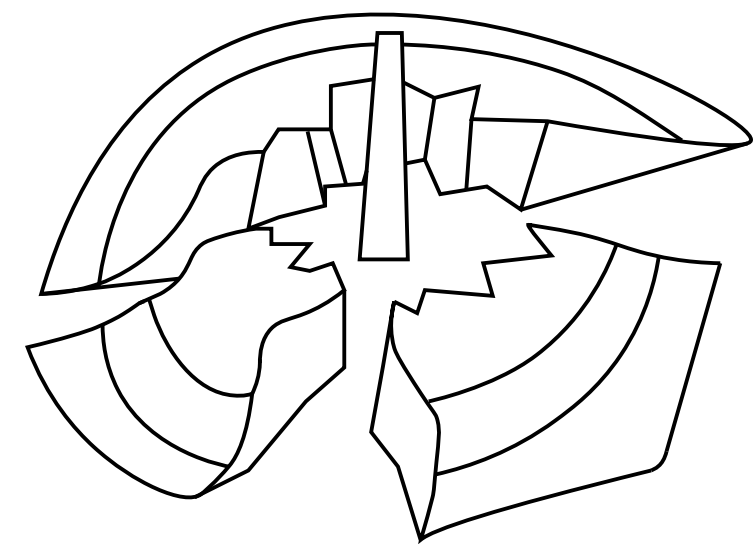
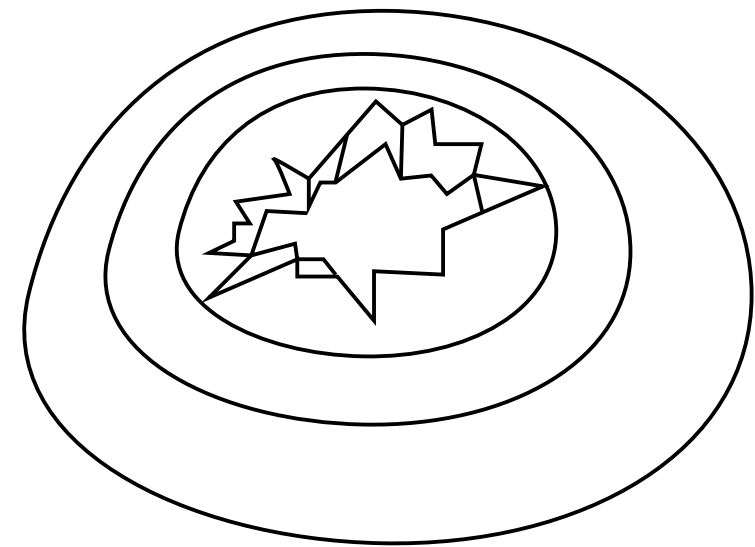
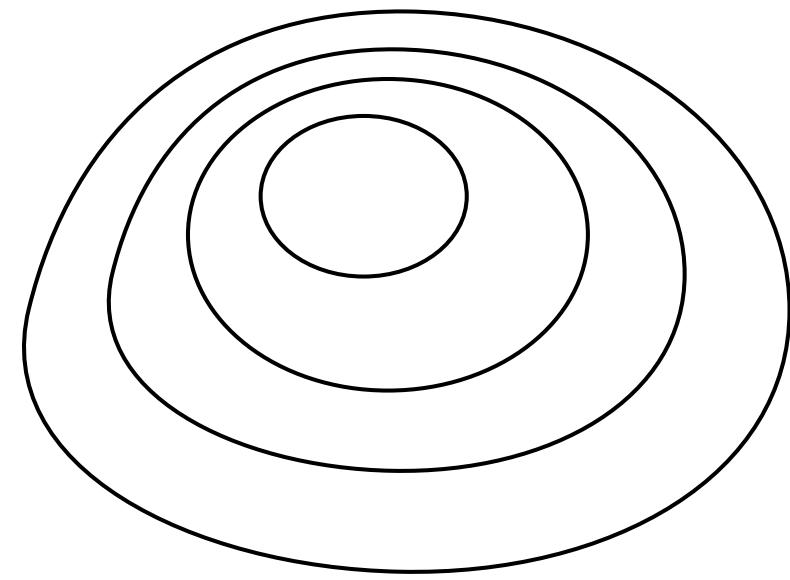

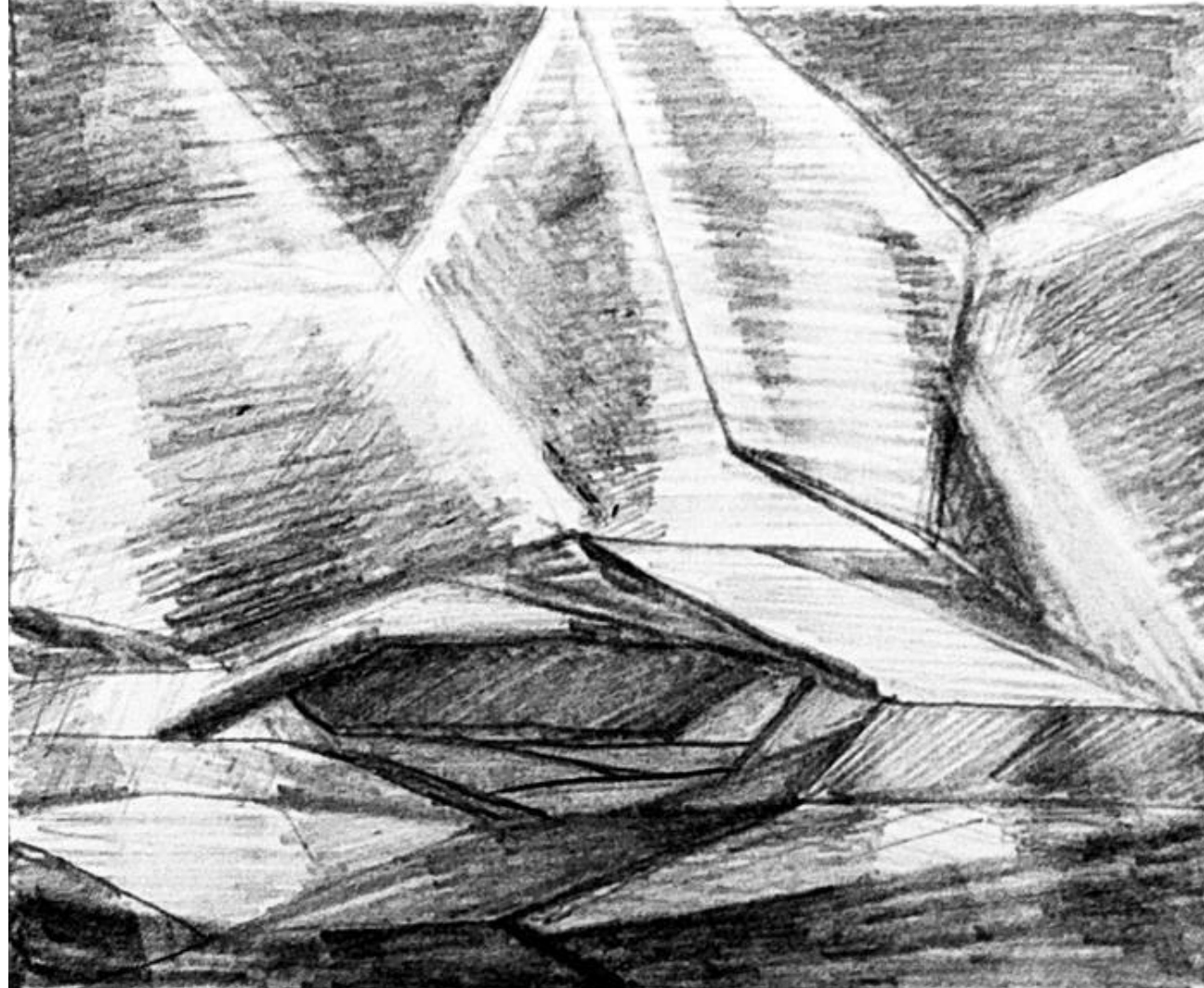
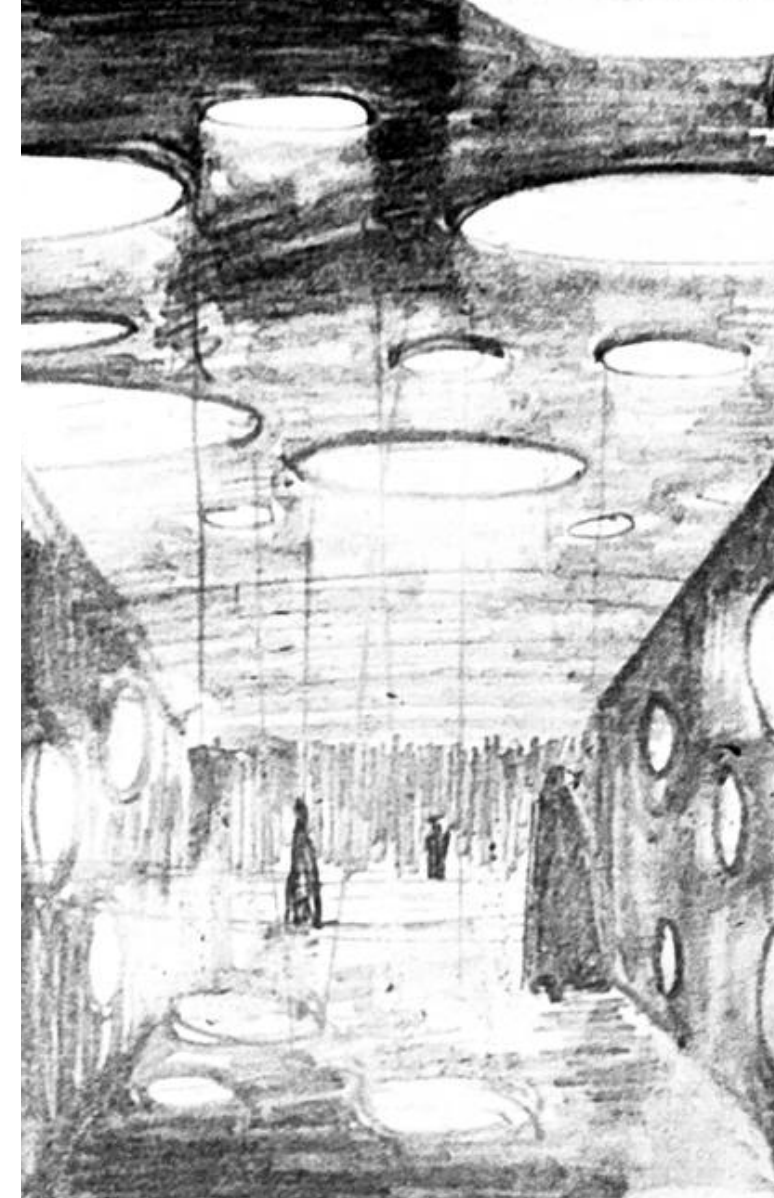
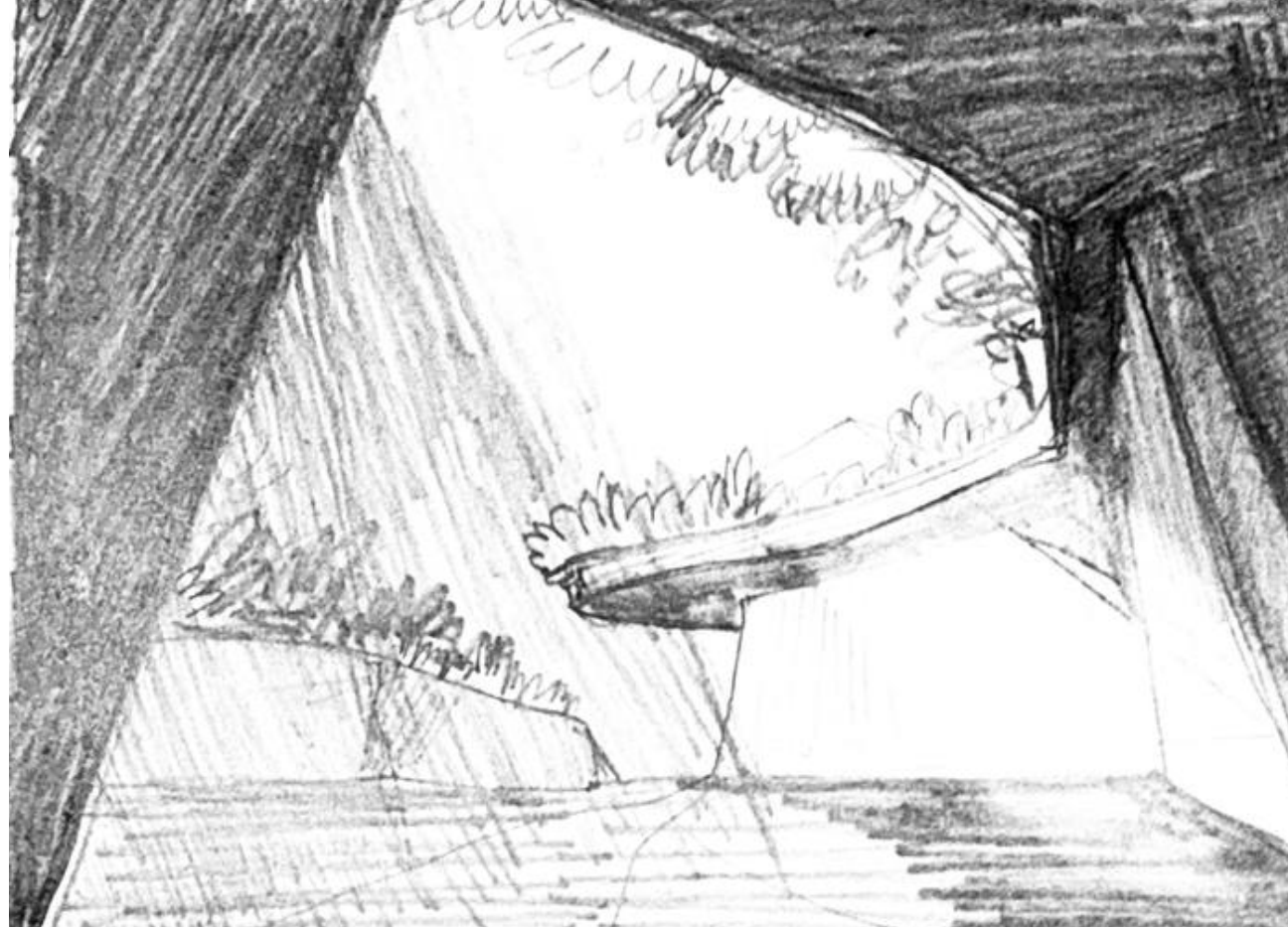

The Memorial Center is a sequence of halls that reveal the events that took place in Argentina at that time. The immersive hall with a geodesic dome has the opportunity to exhibit contemporary artists. It is assumed that the exhibition there will change every quarter and will reflect the vision and reaction of local and international artists on this topic.

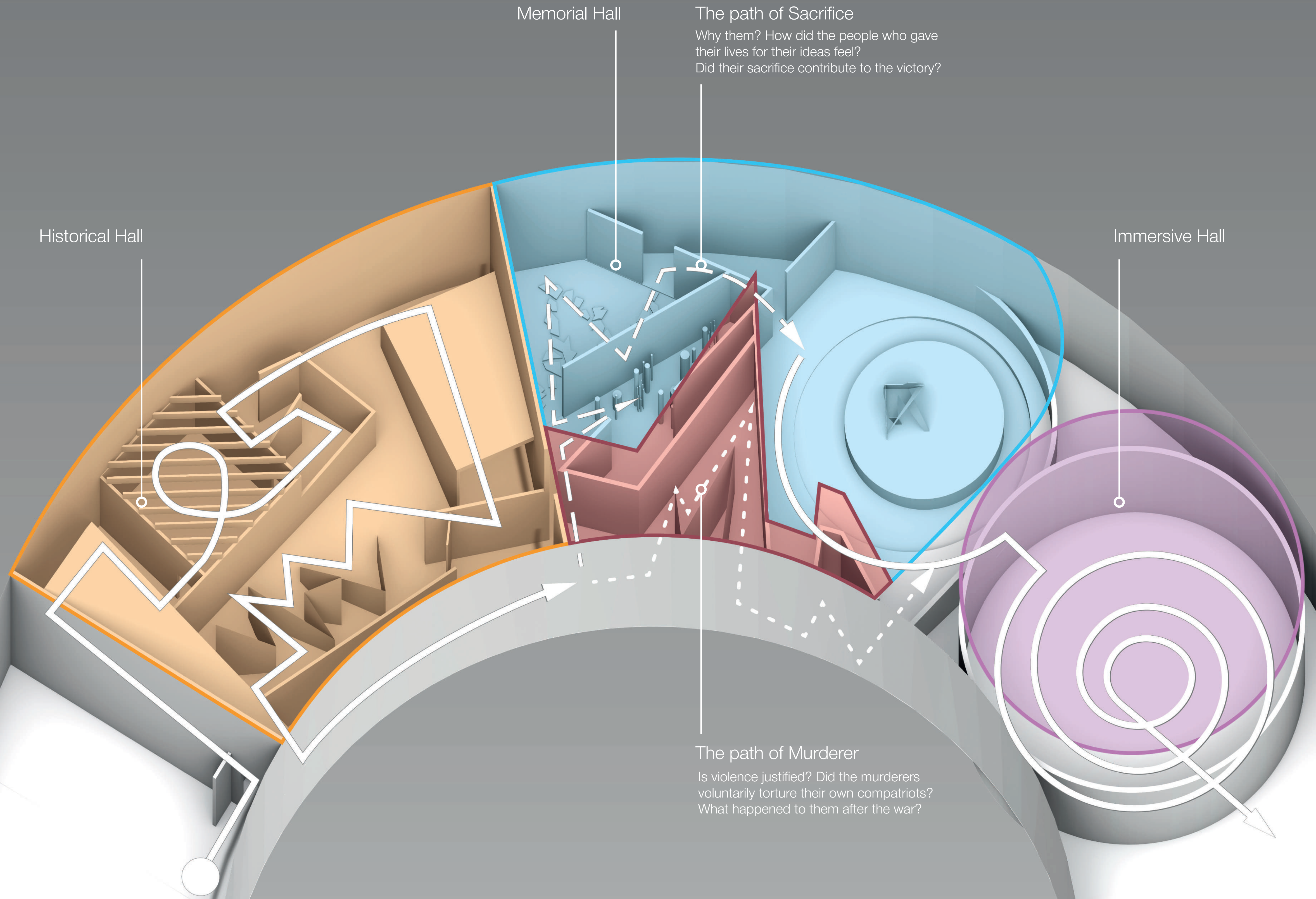

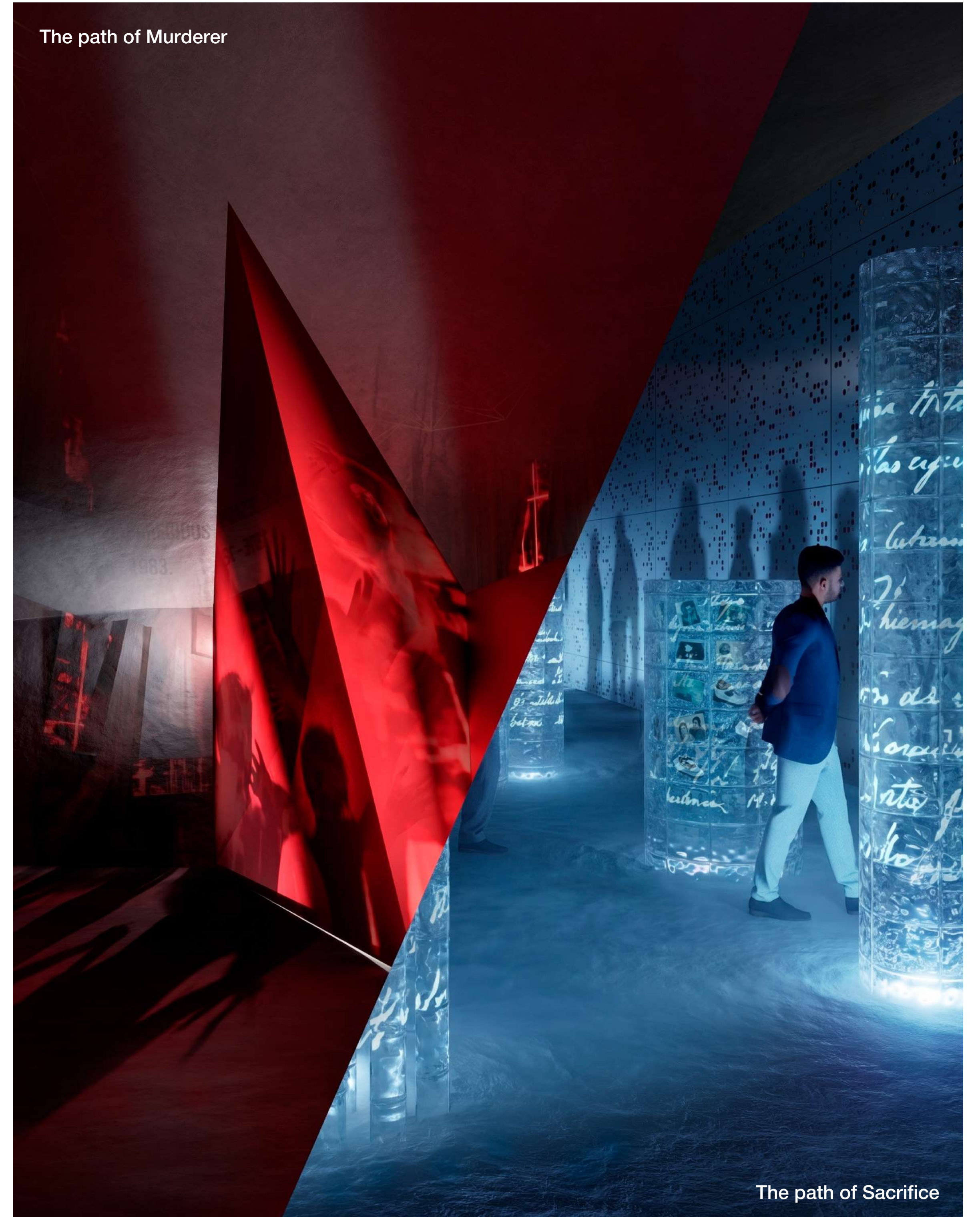



# Quest for truth

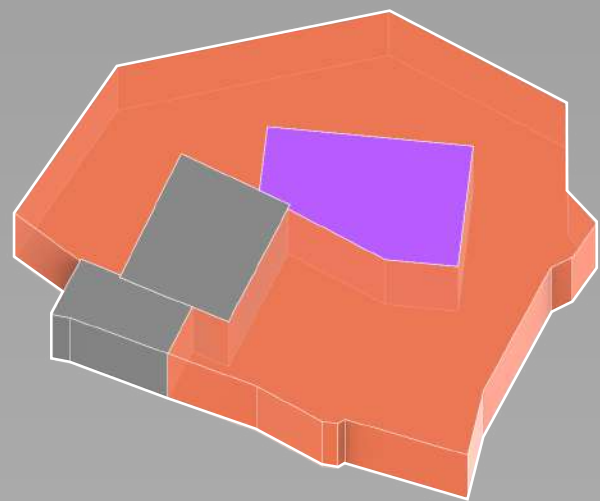
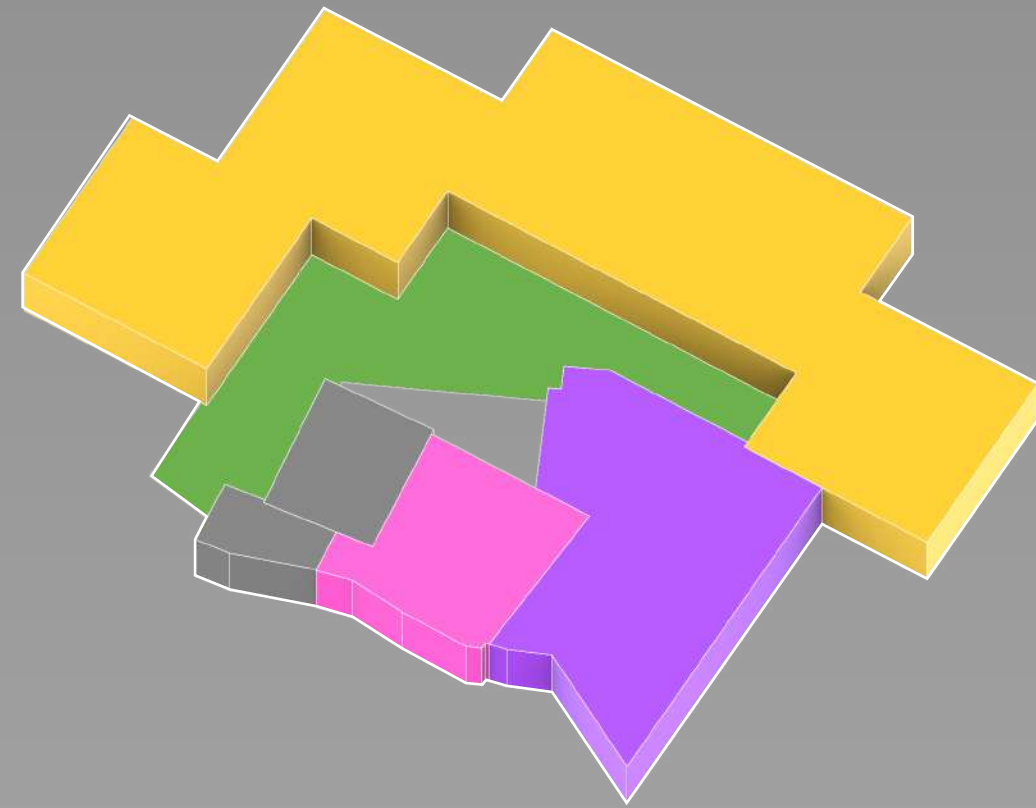
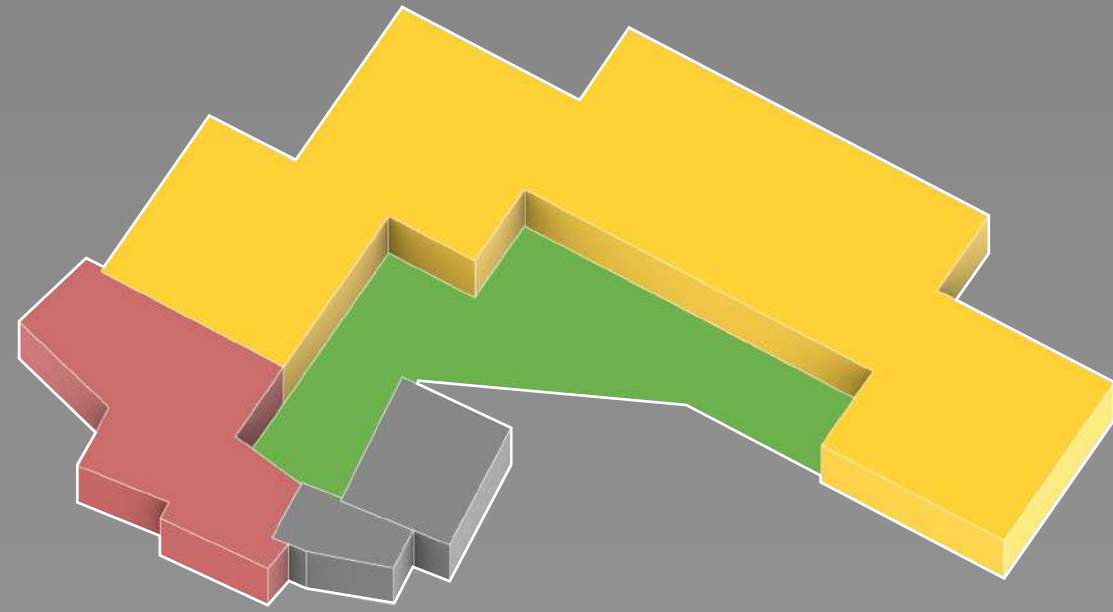

- Classrooms  
2x459 m<sup>2</sup>
  - Library  
186 m<sup>2</sup>
  - Media-library  
68 m<sup>2</sup>
  - Lobby  
289 m<sup>2</sup>
  - Administration  
98 m<sup>2</sup>
  - Recreation  
348 m<sup>2</sup>
  - Services  
159 m<sup>2</sup>
- Total area:  
2066 m<sup>2</sup>

## Plans

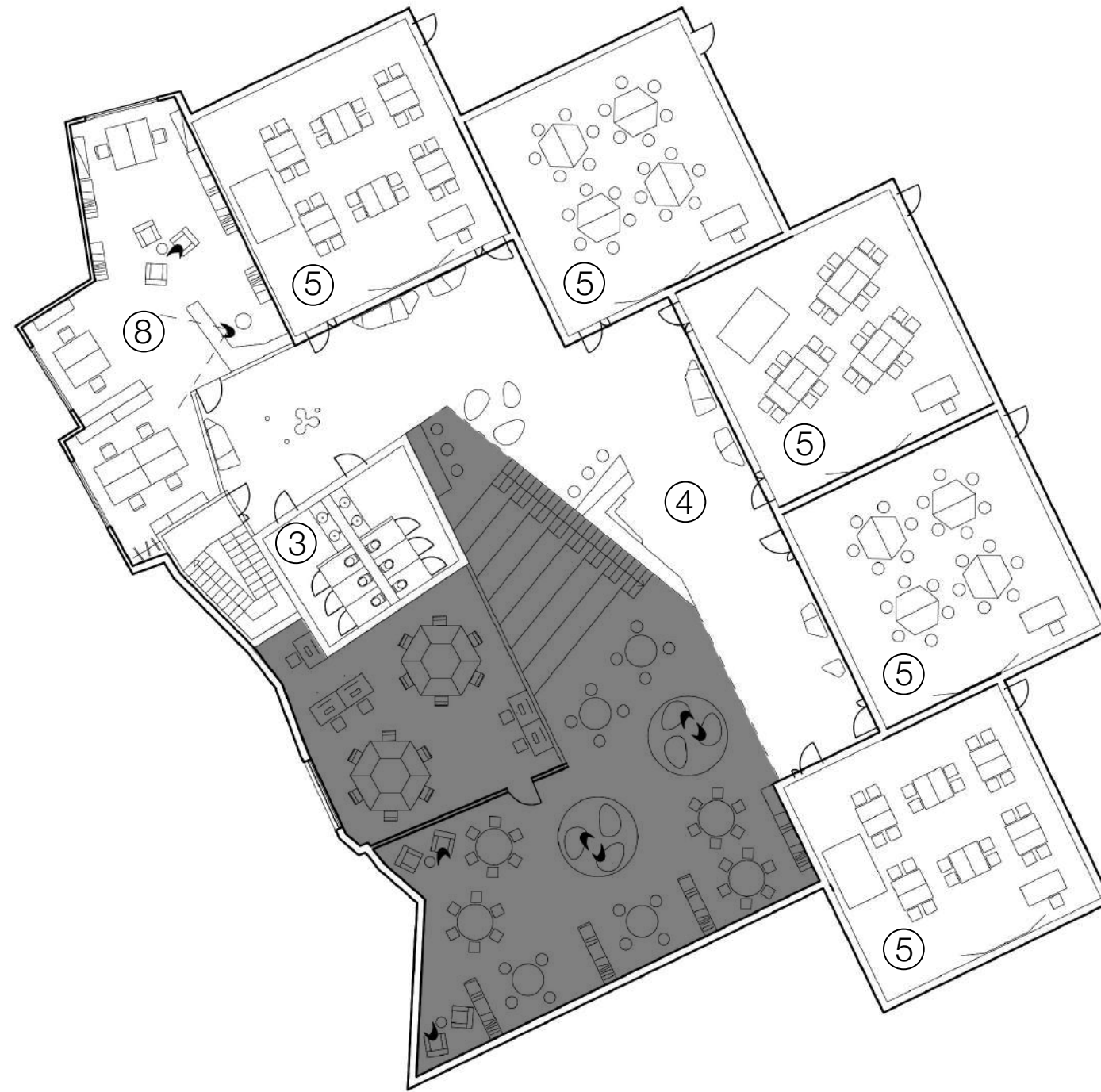

2nd floor

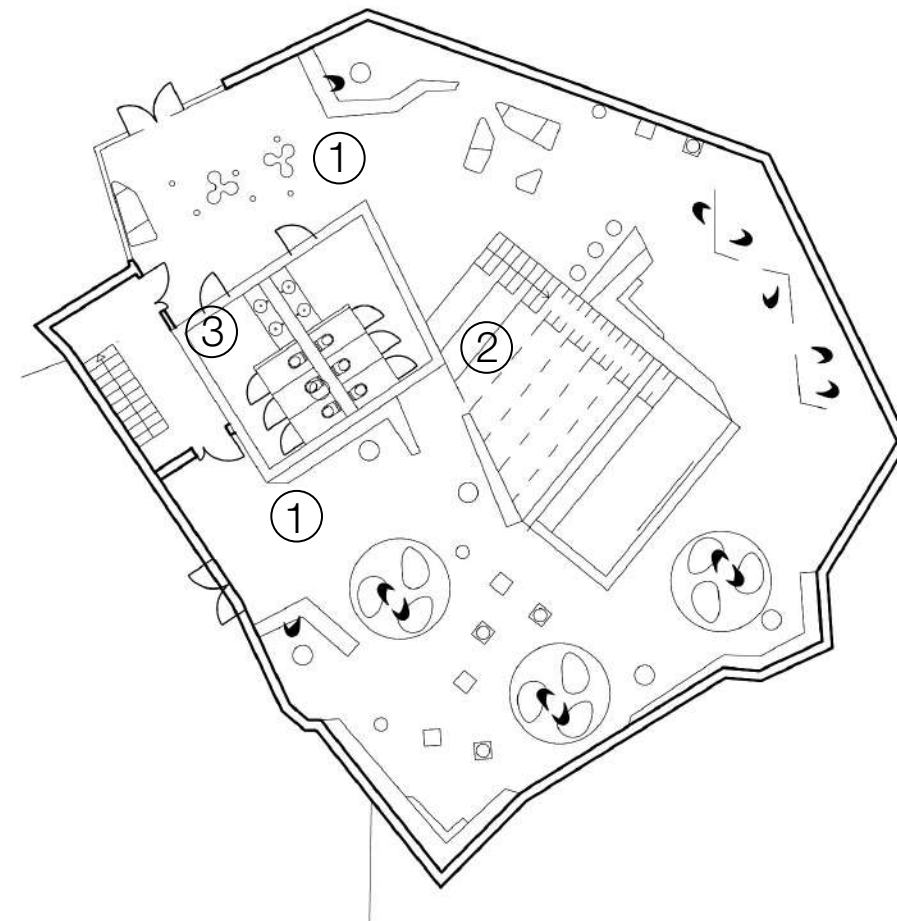

Ground floor

Multipurpose academic complex for educational activities and workshops has 3 floors. The ground floor is a welcoming lobby with installations and amphitheater of the library, which continues on the 2nd floor. There is a media library, 5 classrooms. The administration and classrooms are located on the 3rd floor

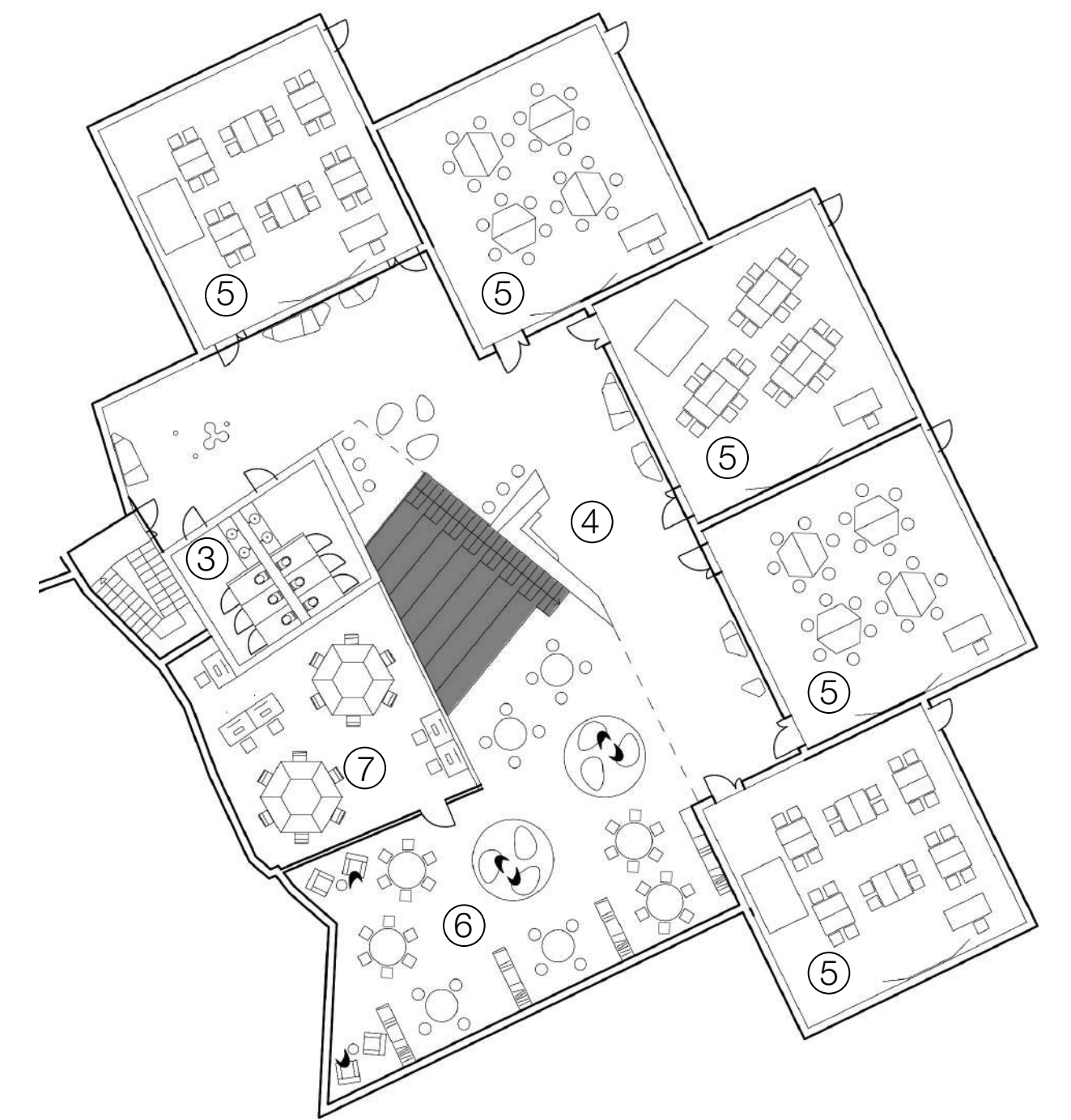

1st floor

- 1-welcoming lobby
- 2-amphitheater
- 3-WC
- 4-recreation
- 5-classroom
- 6-library
- 7-medialibrary
- 8-administration



## Solidarity

The performance and concert hall consists of two levels and a transformable stage that can be adjusted to the needs of the performers. Behind the stage, there's also a technical area for set design, dressing rooms, and equipment control

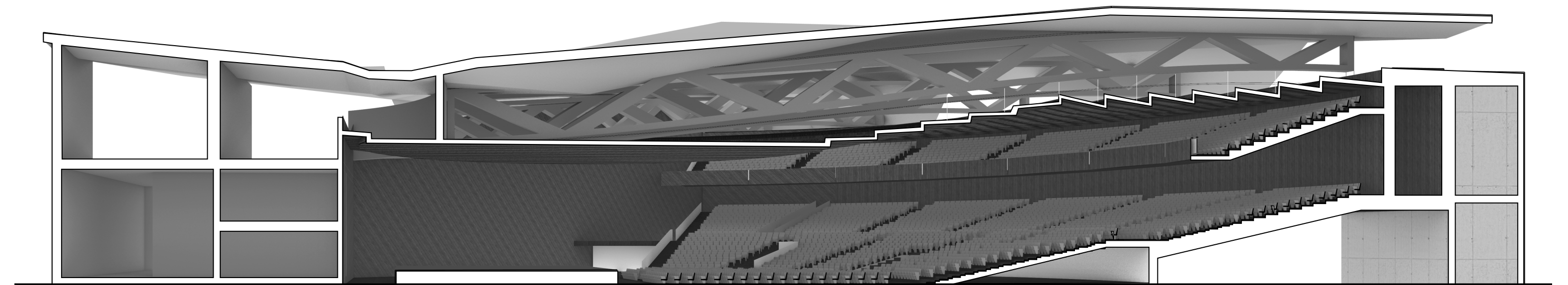
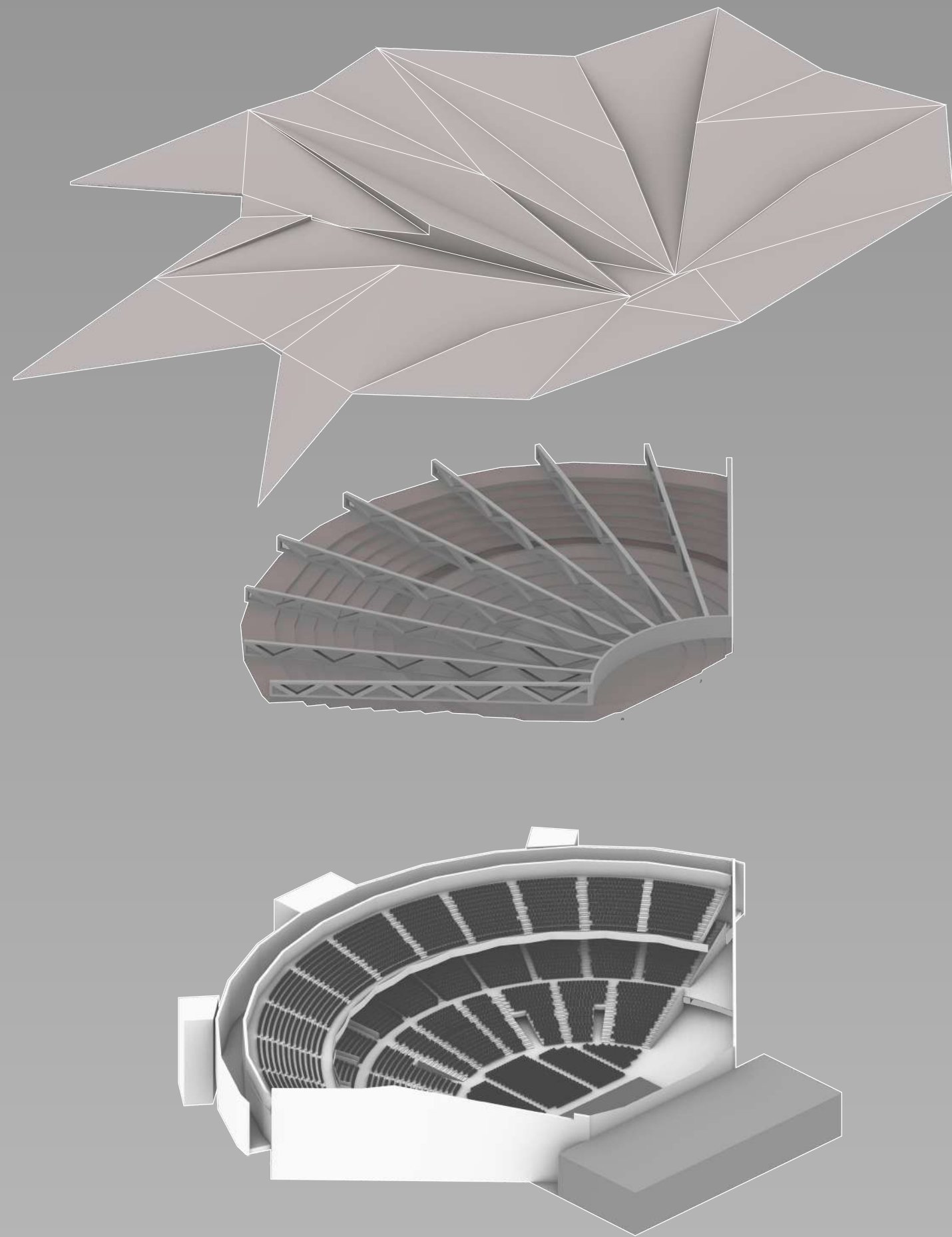

Section



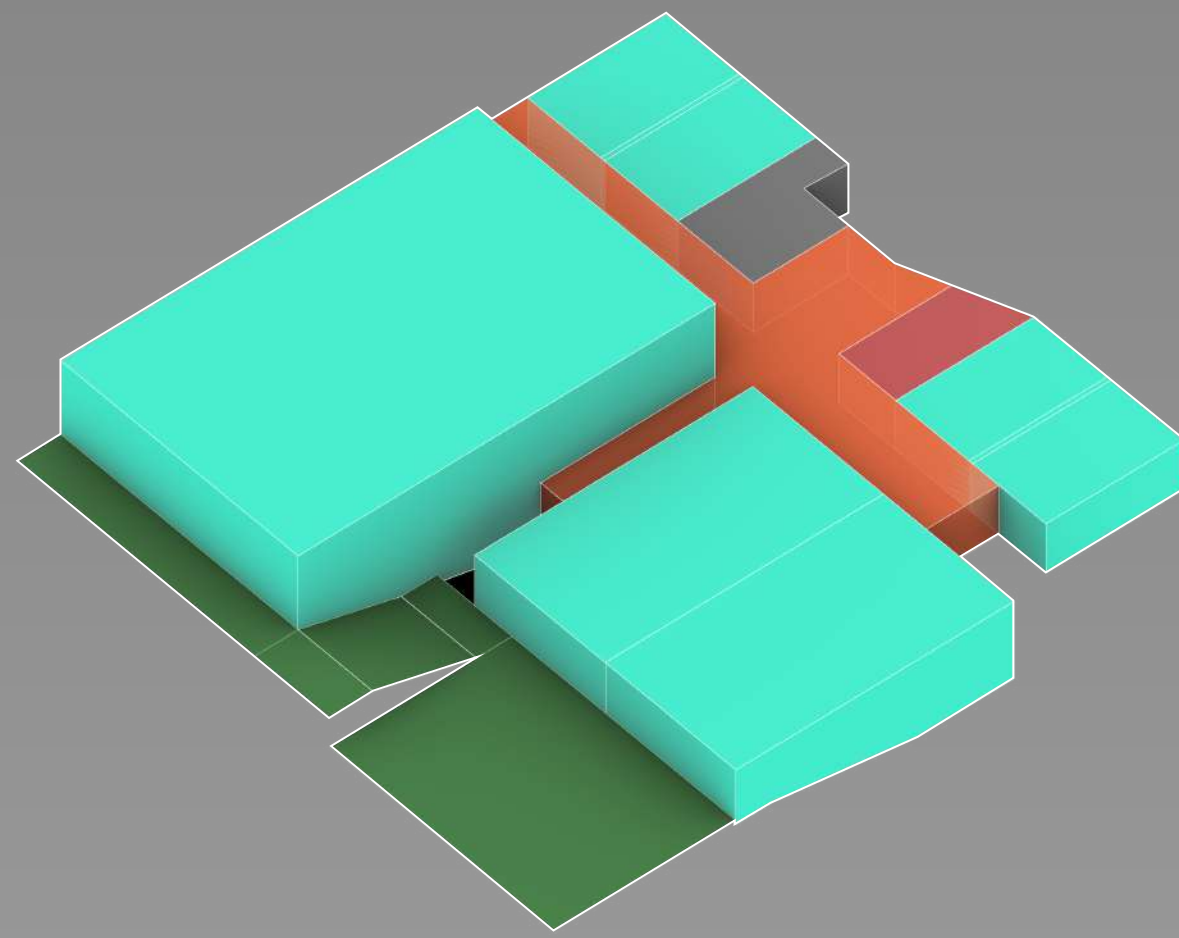

<span style="display:inline-block; width:15px; height:15px; background-color:cyan; border:1px solid black;"></span> Halls 1057 m <sup>2</sup>	<span style="display:inline-block; width:15px; height:15px; background-color:orange; border:1px solid black;"></span> Administration 34 m <sup>2</sup>
<span style="display:inline-block; width:15px; height:15px; background-color:green; border:1px solid black;"></span> Landscape	<span style="display:inline-block; width:15px; height:15px; background-color:gray; border:1px solid black;"></span> Services 41 m <sup>2</sup>
<span style="display:inline-block; width:15px; height:15px; background-color:orange; border:1px solid black;"></span> Lobby 343 m <sup>2</sup>	Total area: 1475 m <sup>2</sup>

## Dialogue

The Conference center for lectures, congresses, exhibitions is simple and understandable for the visitor. The orthogonal grid provides easy navigation and evacuation to the surrounding landscape. It also provides optimal conditions for dialogue and education

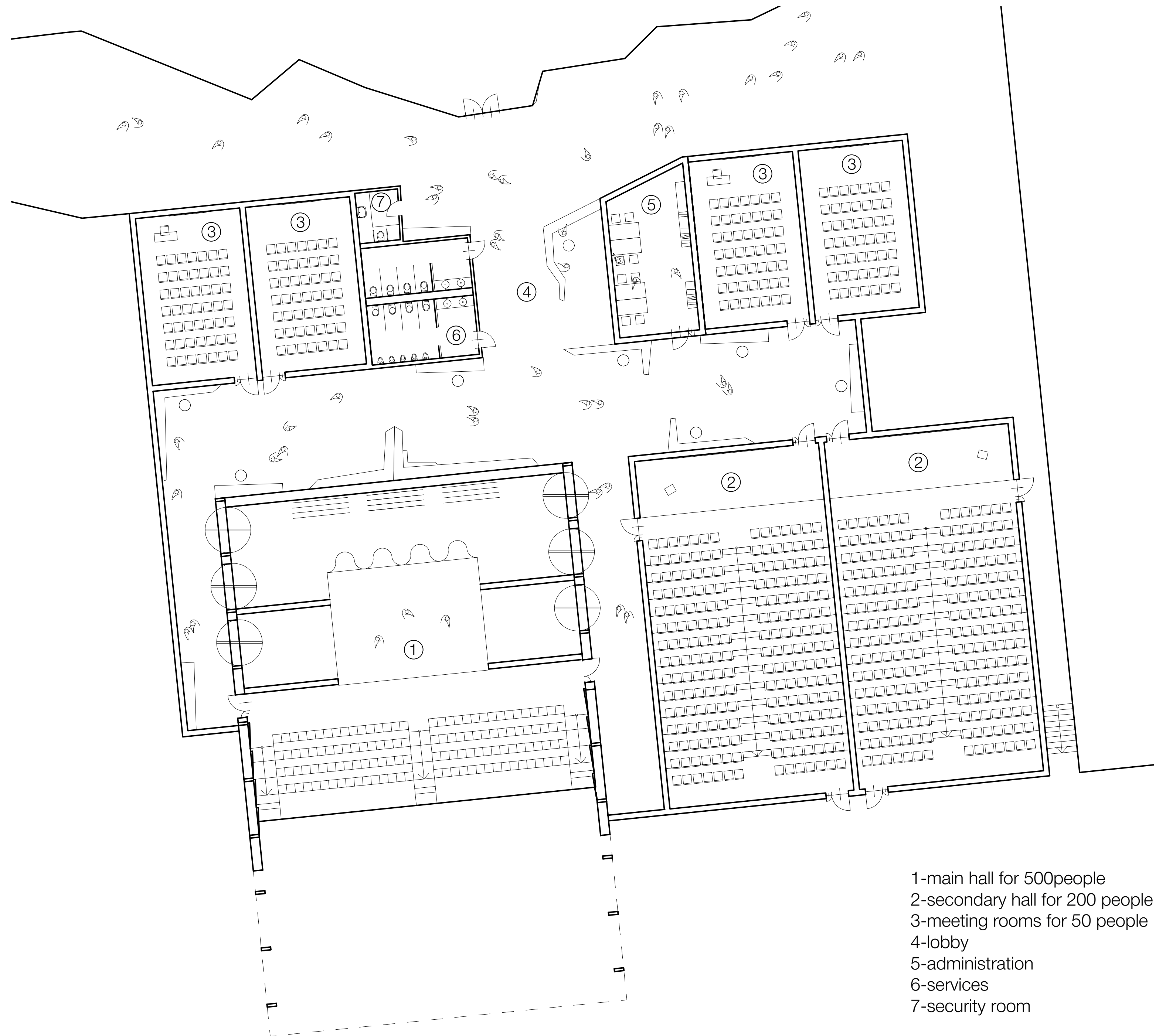

- 1-main hall for 500people
- 2-secondary hall for 200 people
- 3-meeting rooms for 50 people
- 4-lobby
- 5-administration
- 6-services
- 7-security room

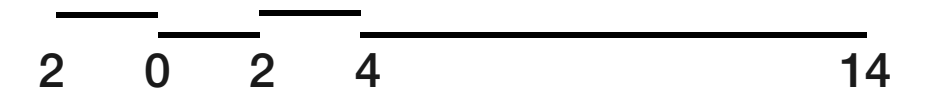

## The path of no return

The path to the galpone was often a person's last. Fear and darkness overwhelm you here. The uneven floor, the rays of light shining through the holes with fragments of nature, like an expression of hope for the best. A figure leaning over you, creaking in the wind, suddenly appearing as the embodiment of the horror to come.

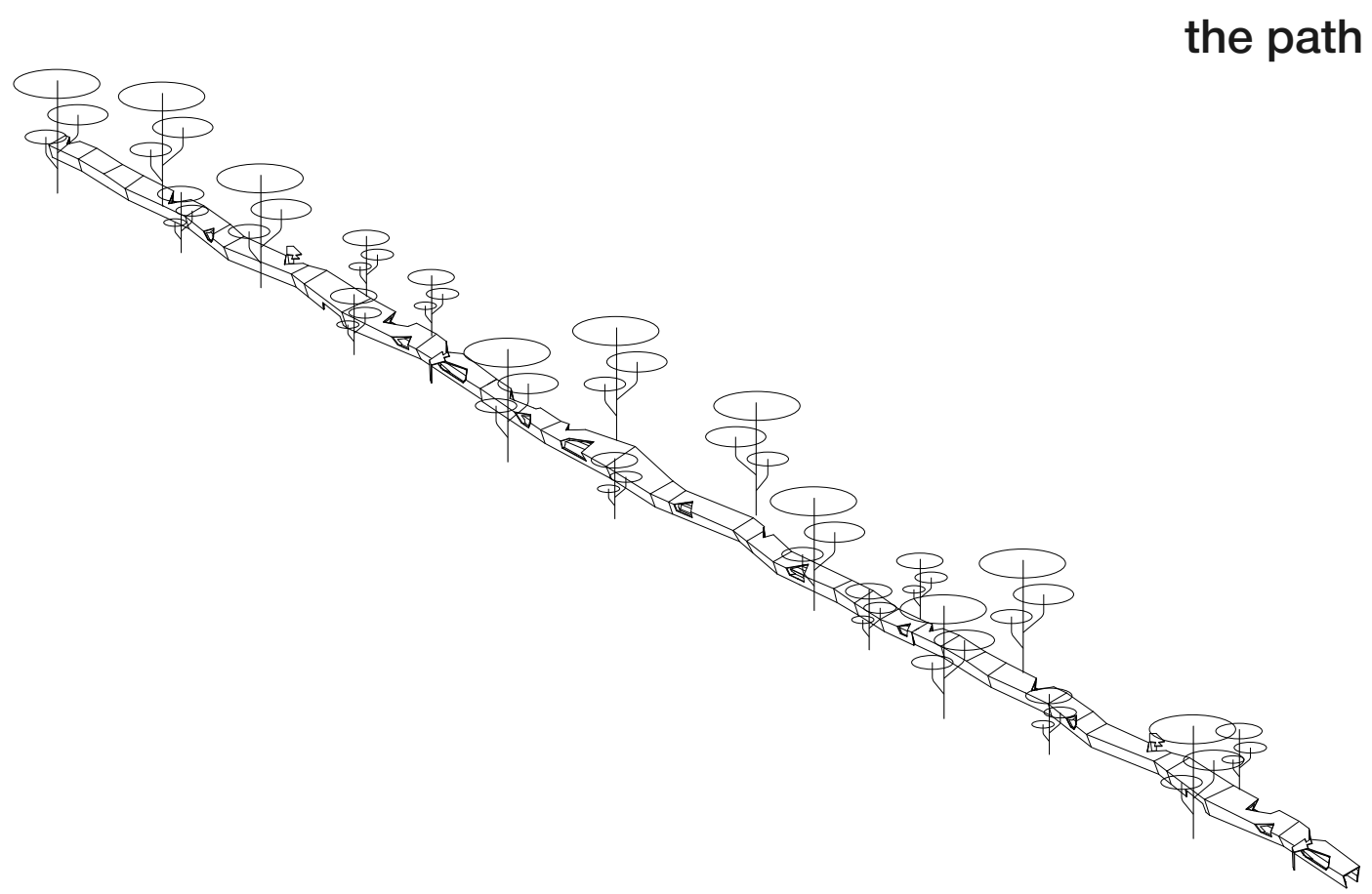
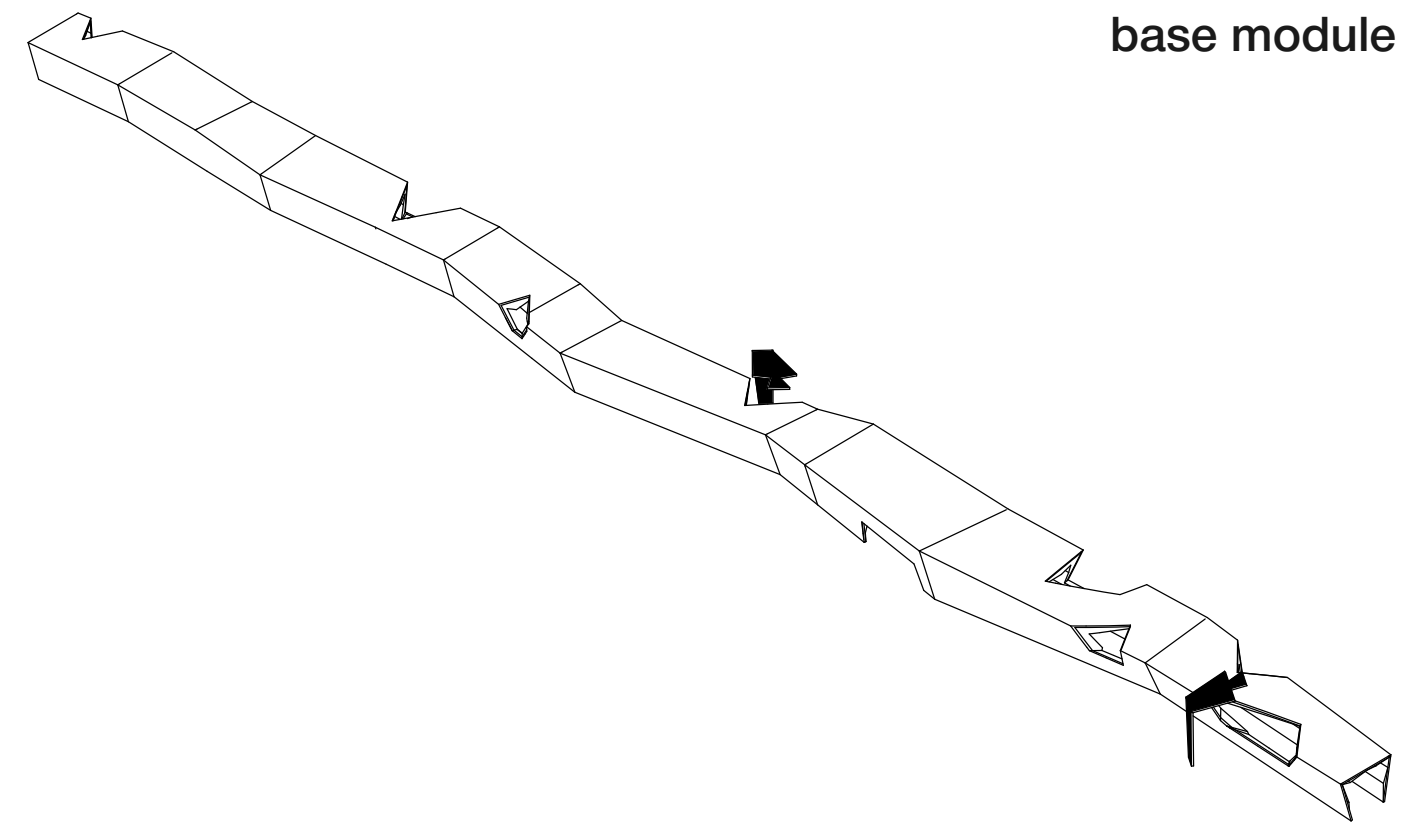

*Everyone is in the reflection*

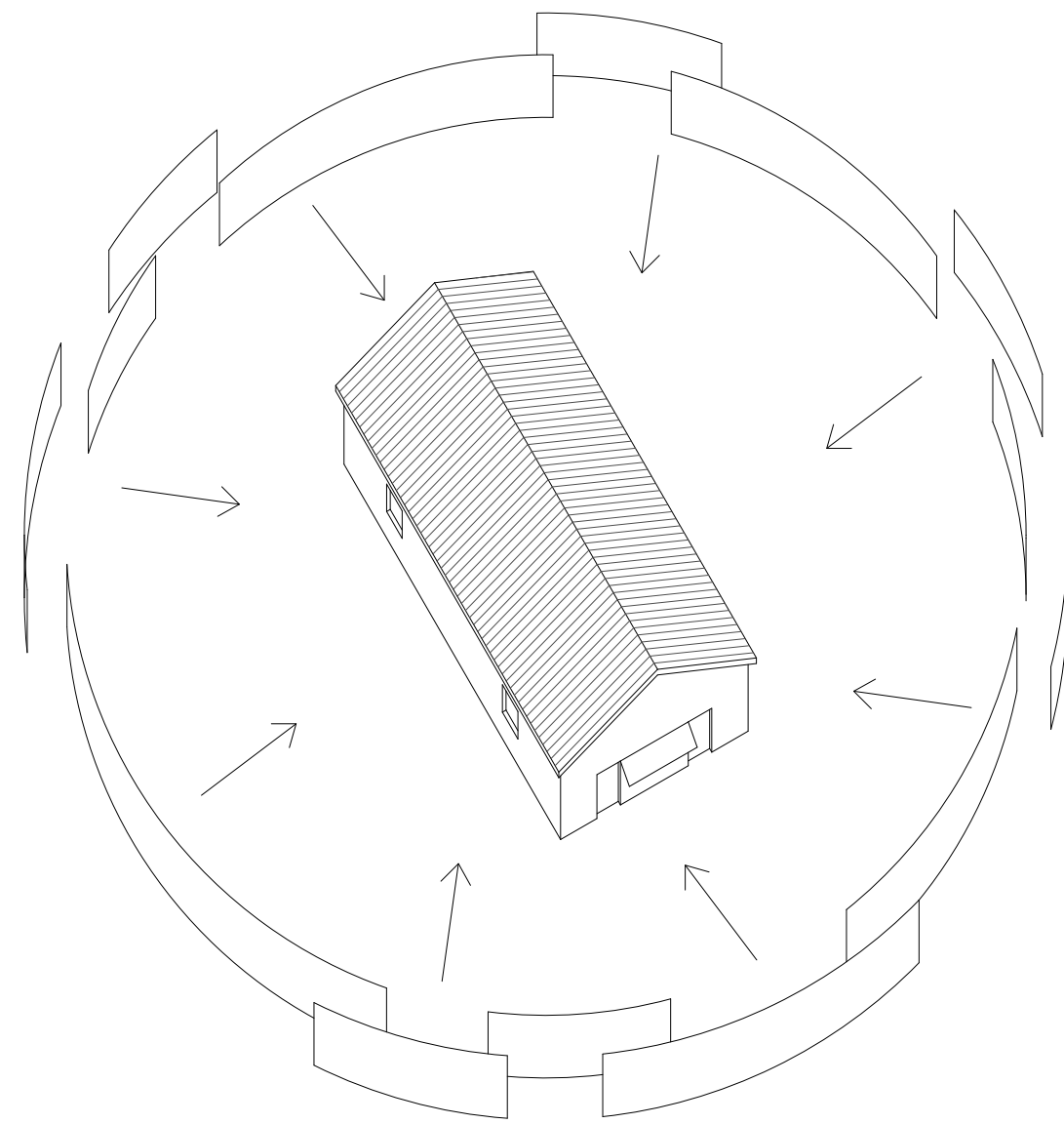

Anyone could be in this place.  
And there was no escape.  
The galpone is surrounded by mirrored surfaces, looking at which you see yourself against its background every time. The place of imprisonment becomes ubiquitous and inevitable

