



## THE SHARED SPOON

NEW FLAVOURS, OLD STORIES @ THE CLONAKILTY OLD MILL

The final design scheme proposes a sensitive intervention within the existing mill building, transforming the space into a community-focused environment centred around food culture, education, and social interaction. The scheme is informed by the concept of tapering, developed through observational sketches and onion studies, which guided the formation of walls, thresholds, and circulation throughout the project.

Spatial experiences of compression, release, and framed views were used to create a layered journey through the building, encouraging moments of pause, interaction, and discovery. The proposal balances preservation and intervention by retaining the industrial character of the existing structure while introducing clear and restrained architectural elements that support contemporary public use. Through exhibitions, workshops, cooking classes, and communal spaces, the design aims to strengthen connections between food, heritage, and community within Clonakilty.

### MATERIAL BOARD



### CONCEPT DRAWINGS

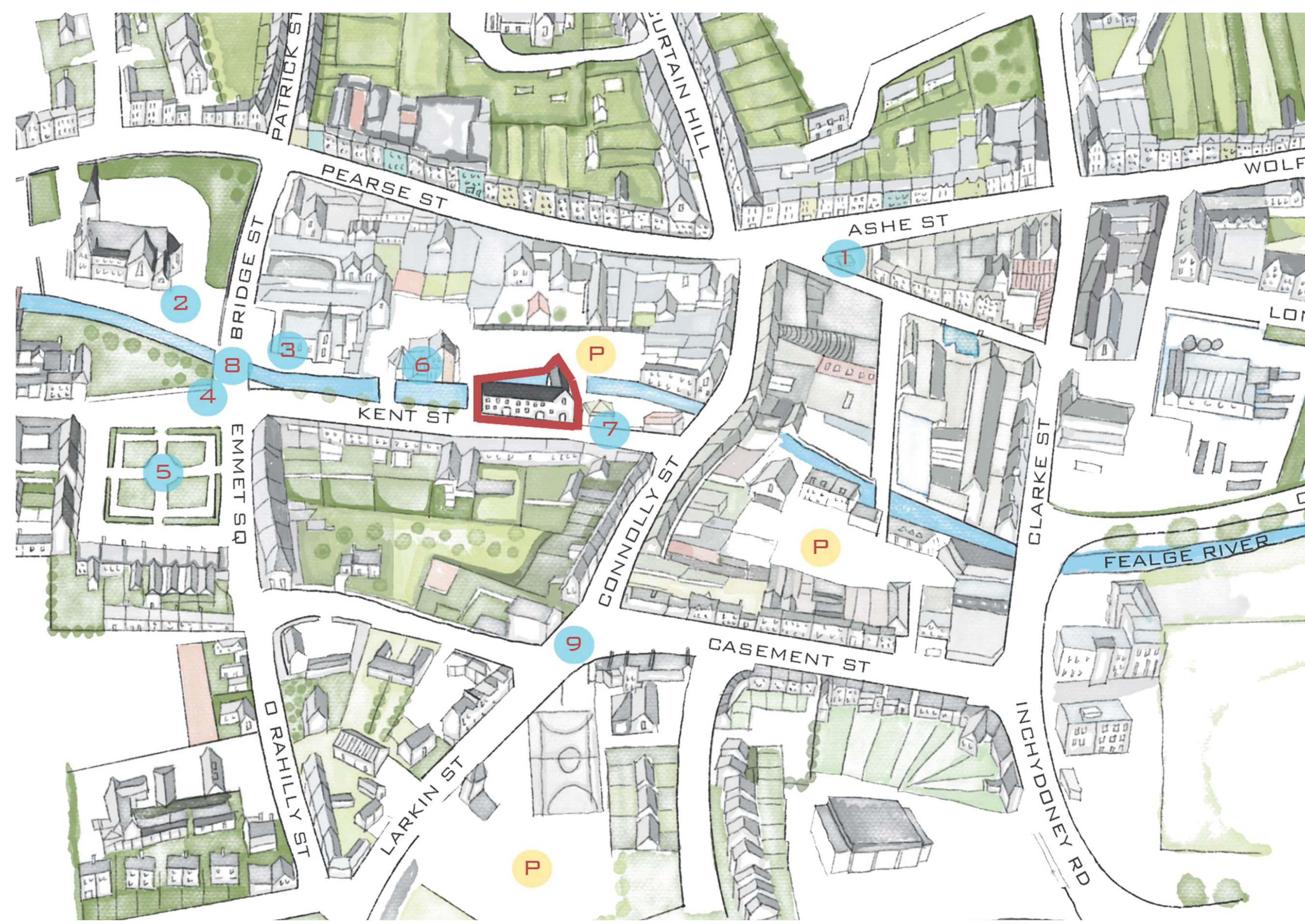

### SITE SKETCH

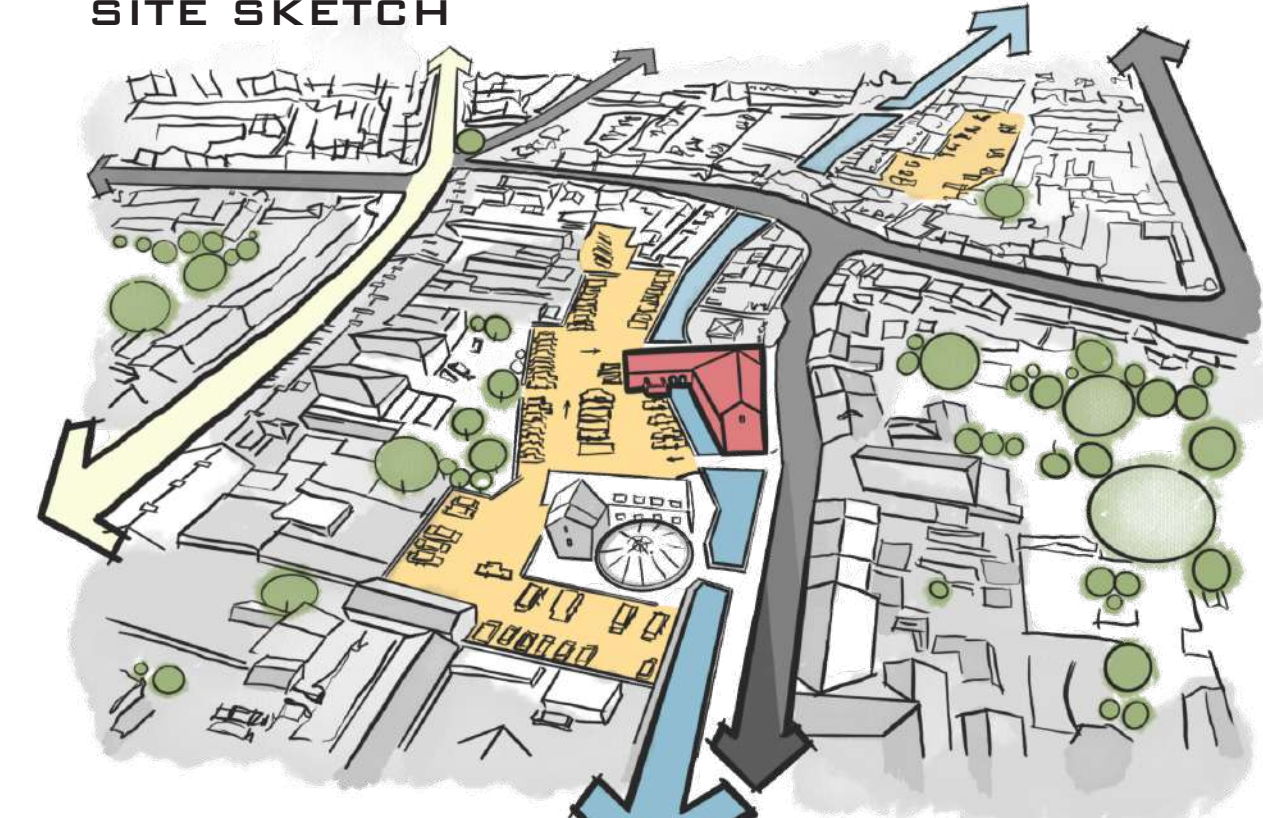

### APPROACH SKETCH PLAN

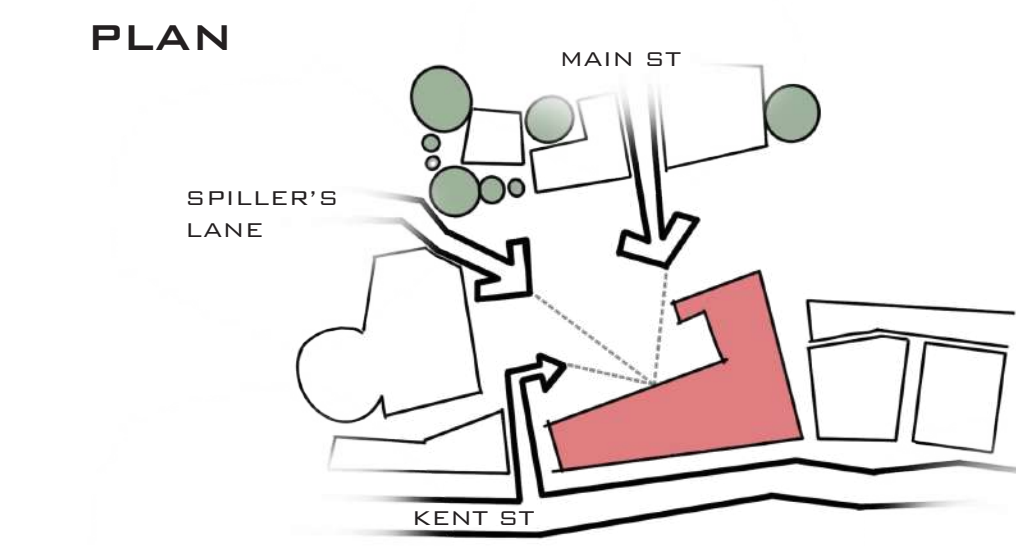

### APPROACH SKETCH PERSPECTIVE

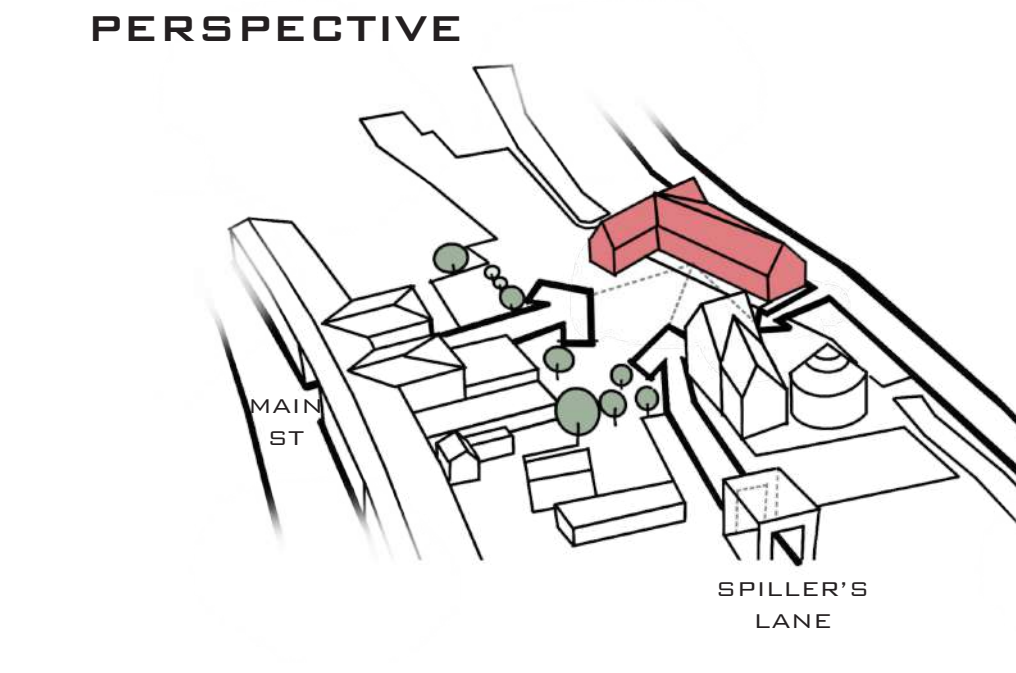

### SITE PLAN

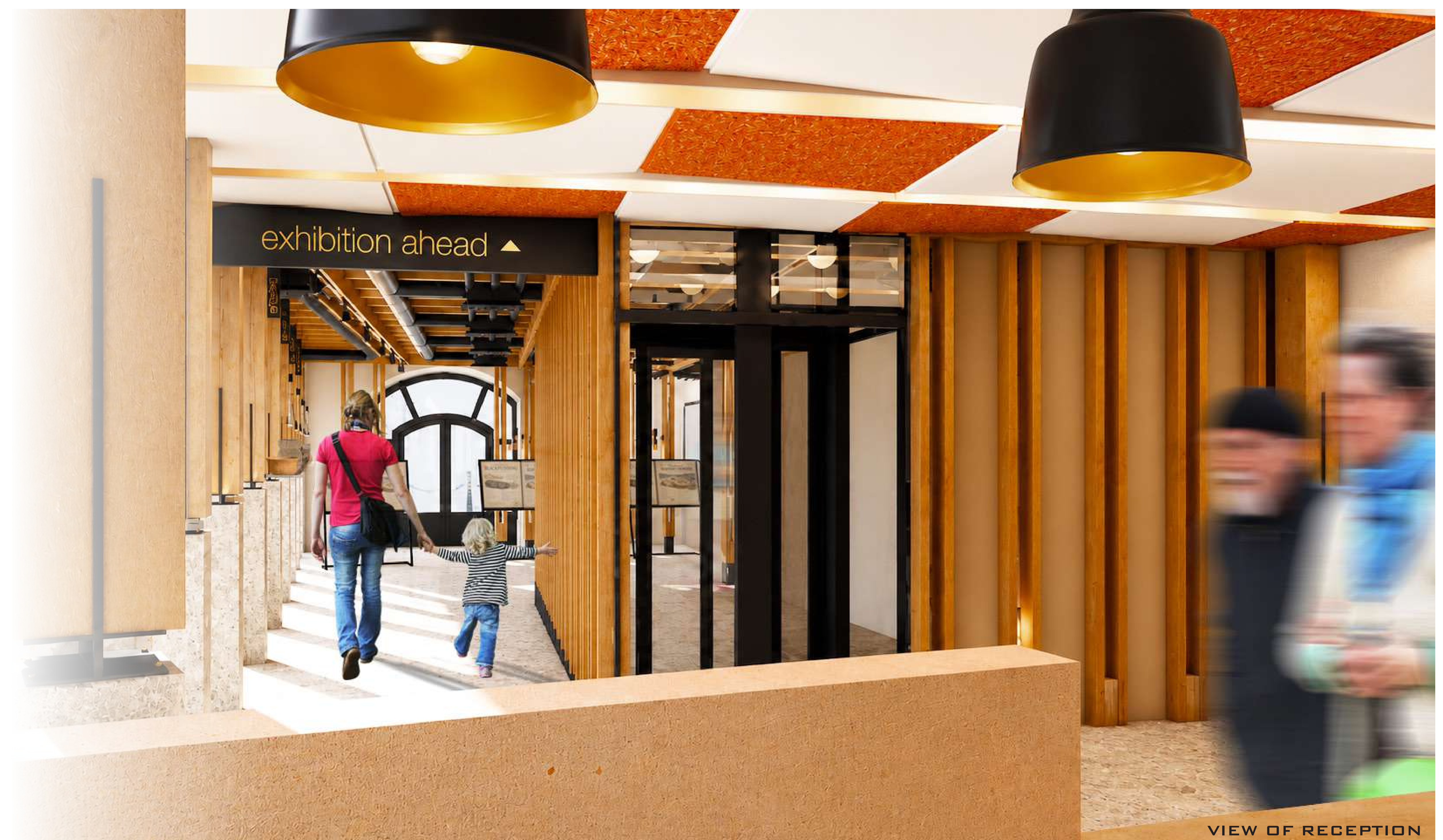
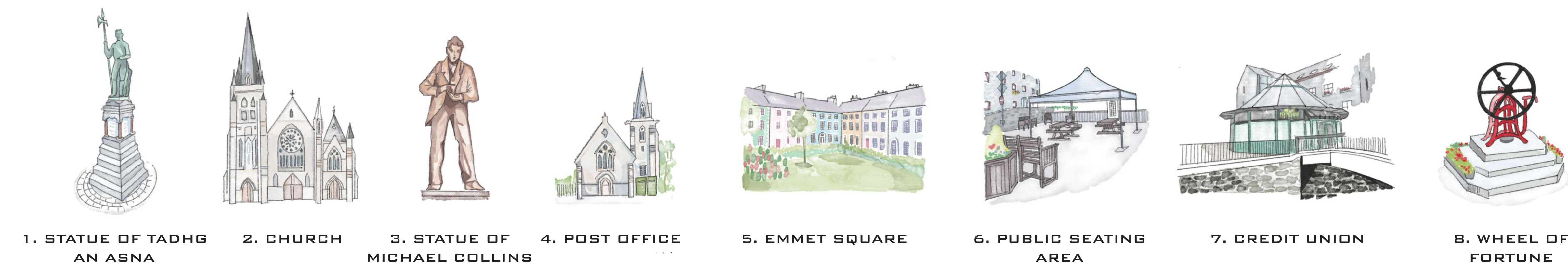

VIEW OF RECEPTION



VIEW OF RECEPTION



VIEW OF TEMPORARY EXHIBITION

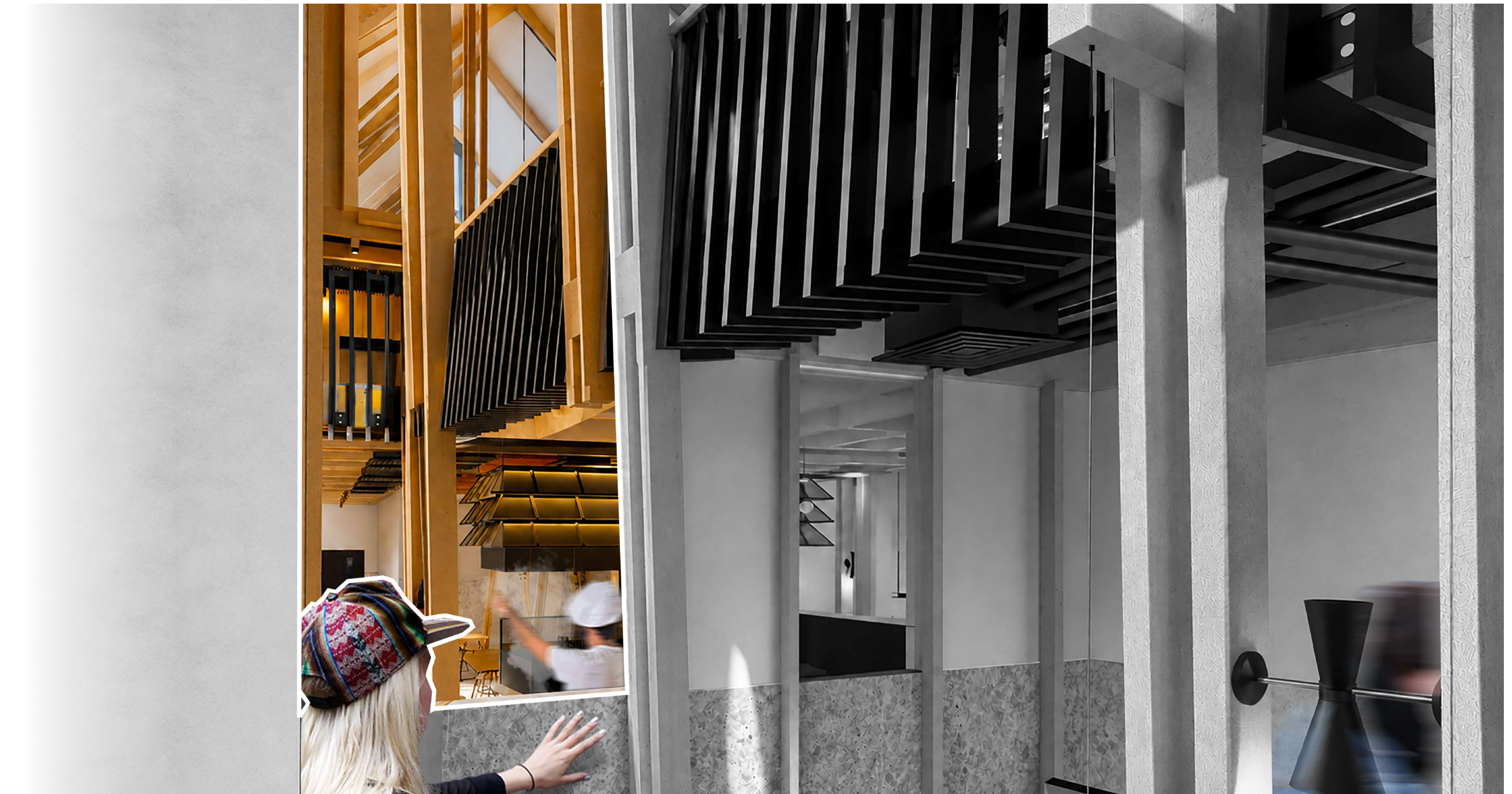

GLIMPSE FROM TEMPORARY EXHIBITION INTO RESTAURANT

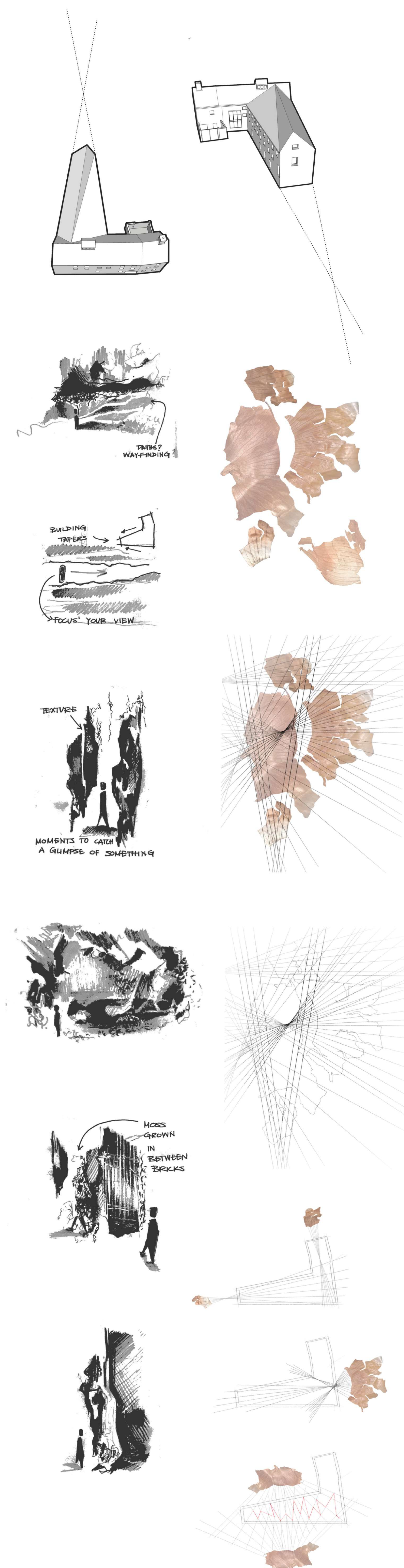

SOUTH ELEVATION



VIEW OF DEMO KITCHEN

VIEW OF DEMO KITCHEN

RESTAURANT  
CEILING INTERVENTION

FIRE CORE  
B

FARMER'S  
WORKSHOP

DEMO  
KITCHEN

VIEWING  
ROOM (FLEXIBLE)

CHANGING  
ROOMS

FIRE CORE  
A

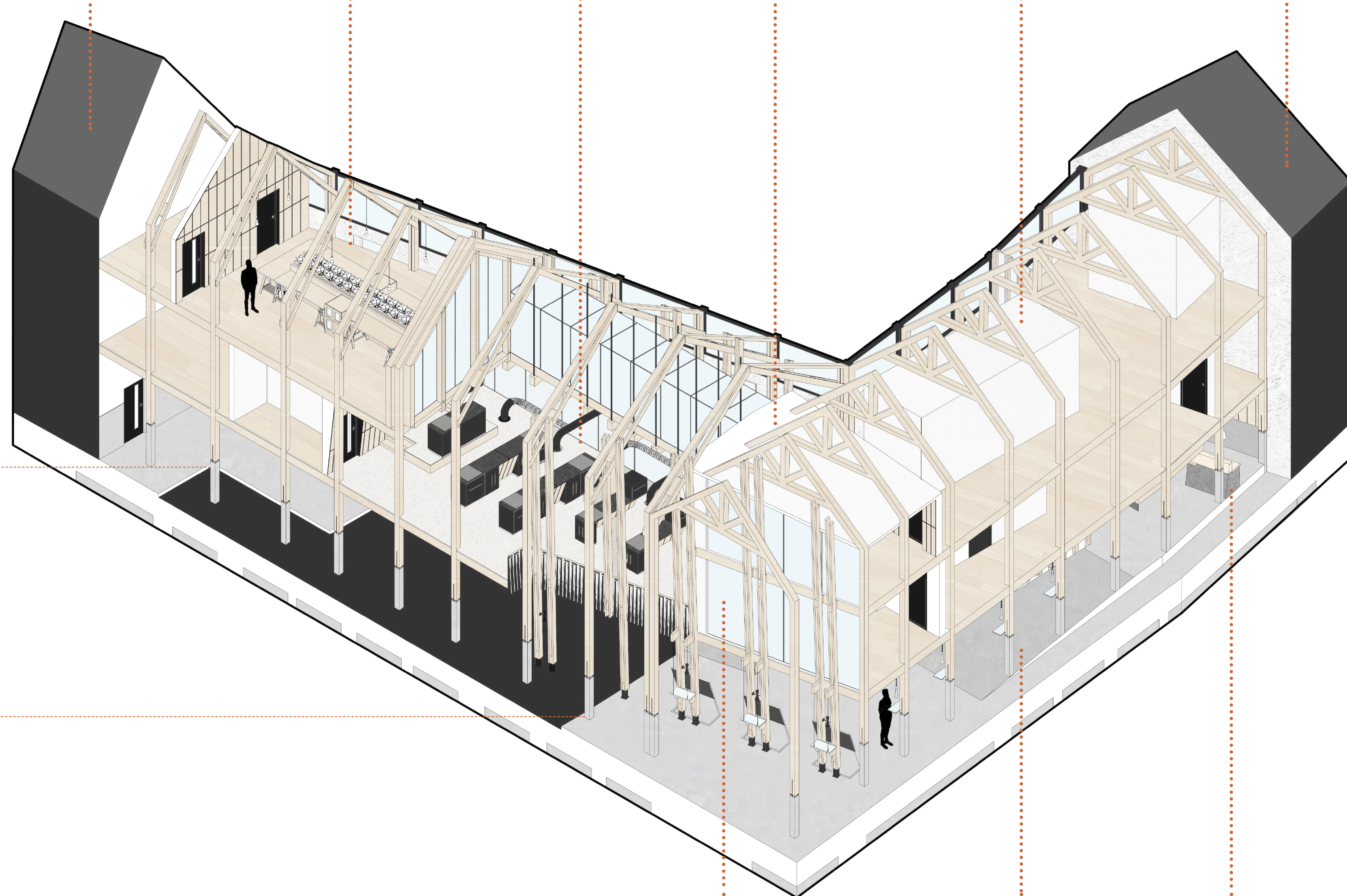
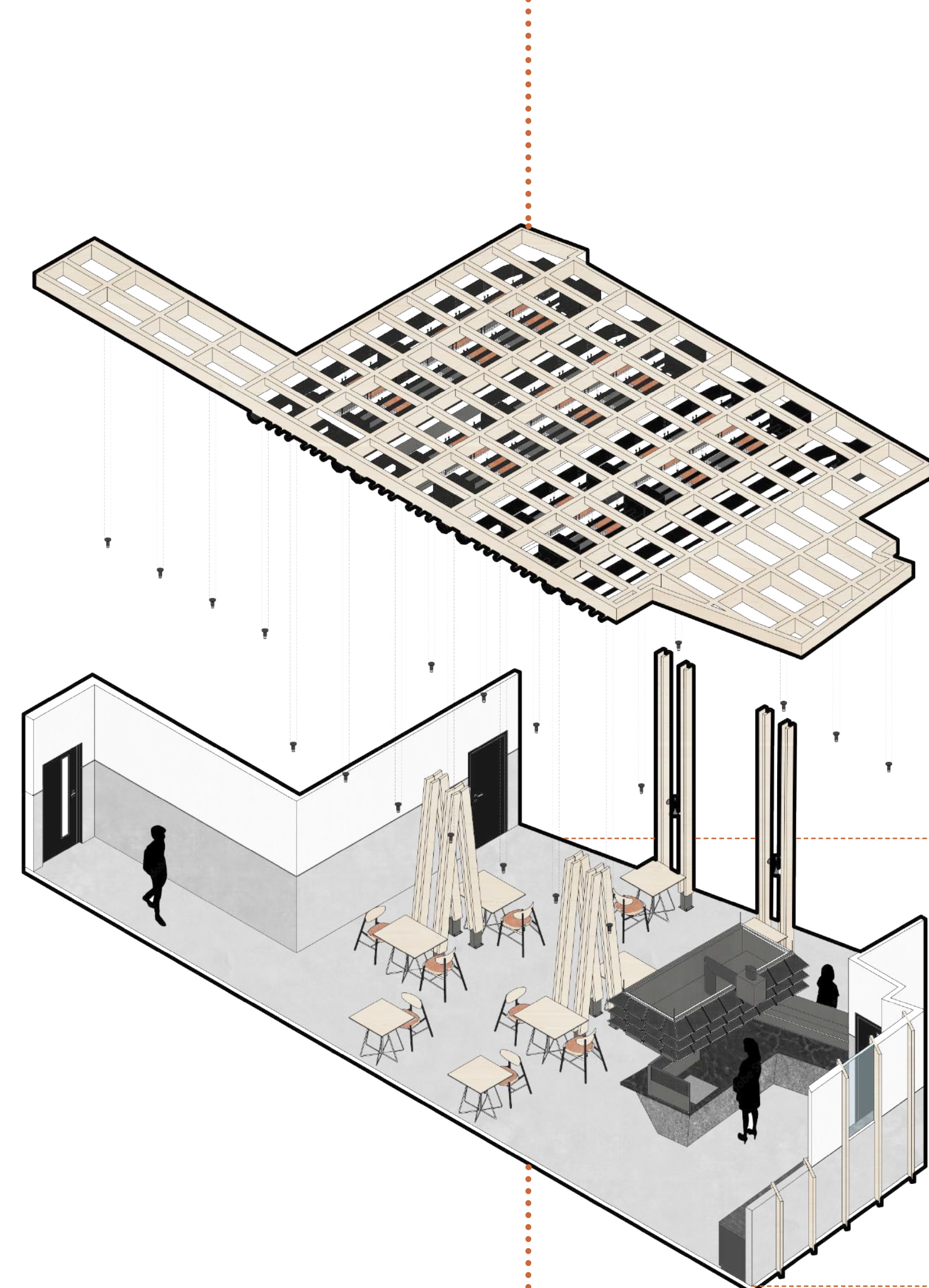

RESTAURANT

COMMUNAL  
DINING

TEMPORARY  
EXHIBITION

RECEPTION

PART EXPLODED ISOMETRIC



VIEW OF RESTAURANT



VIEW OF TEMPORARY EXHIBITION

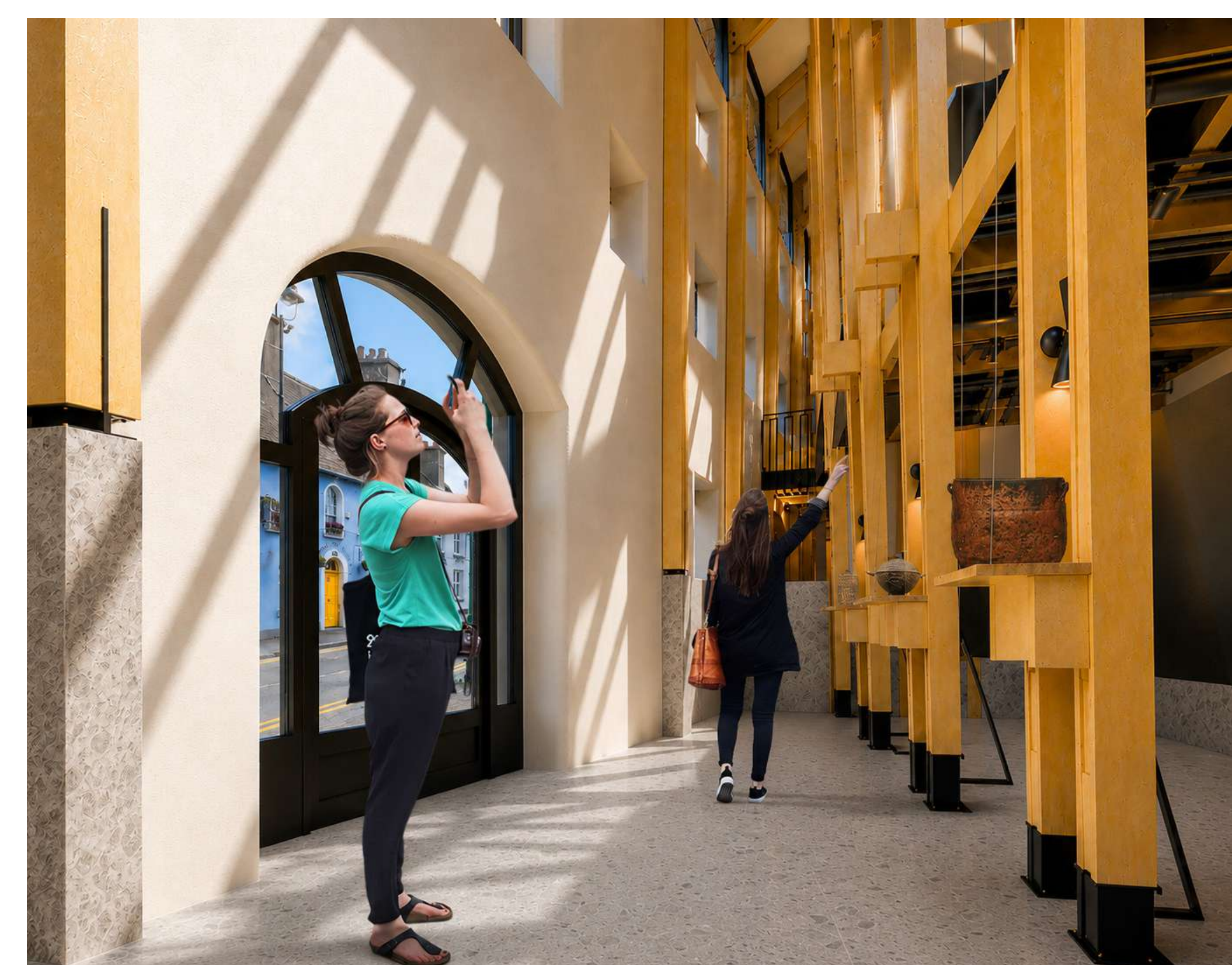

VIEW OF TEMPORARY EXHIBITION

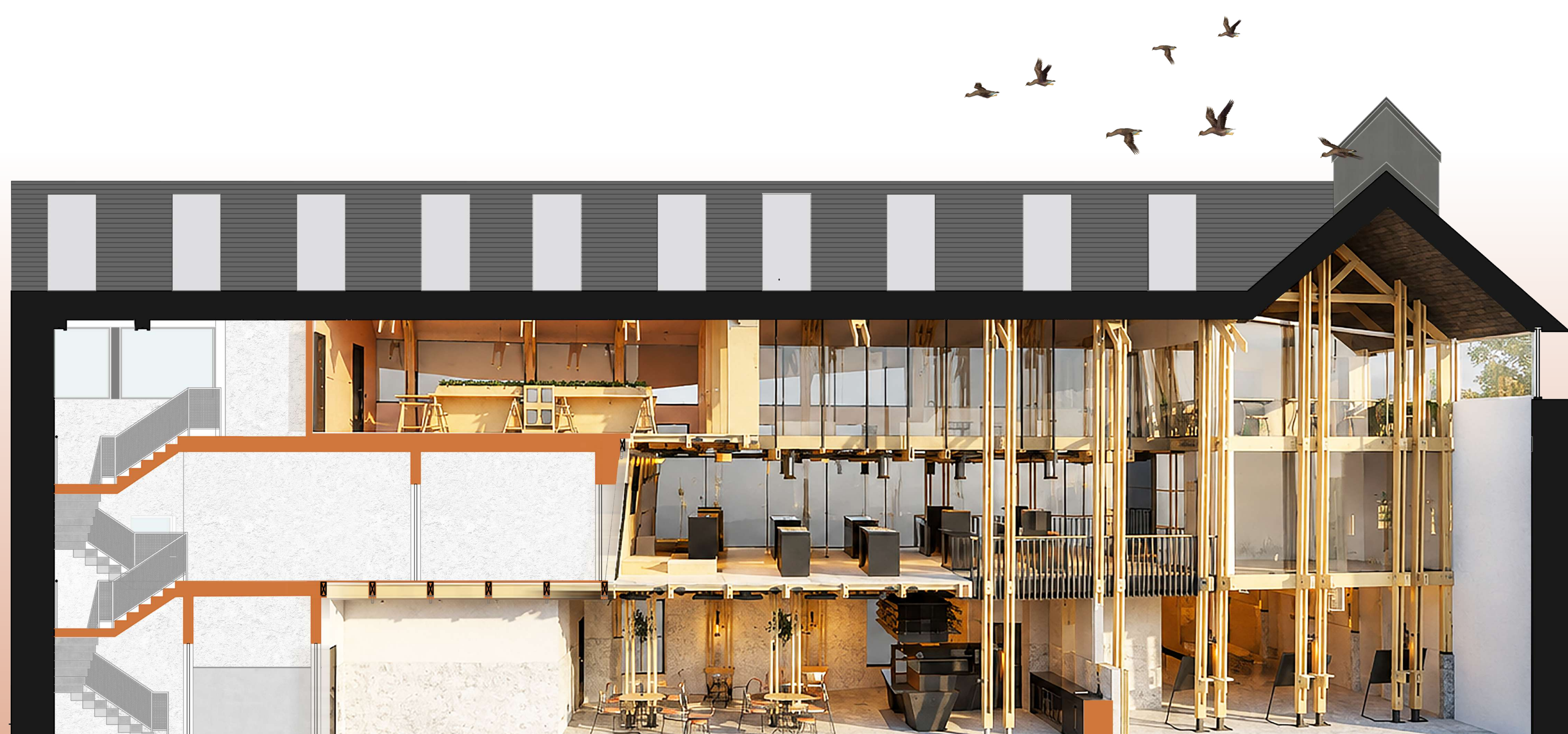

SECTIONAL PERSPECTIVE



GLIMPSE FROM VIEWING ROOM INTO DEMO KITCHEN



INITIAL GLIMPSE FROM VIEWING ROOM INTO DEMO KITCHEN



VIEW OF TRANSPORT NEAR EXHIBITION

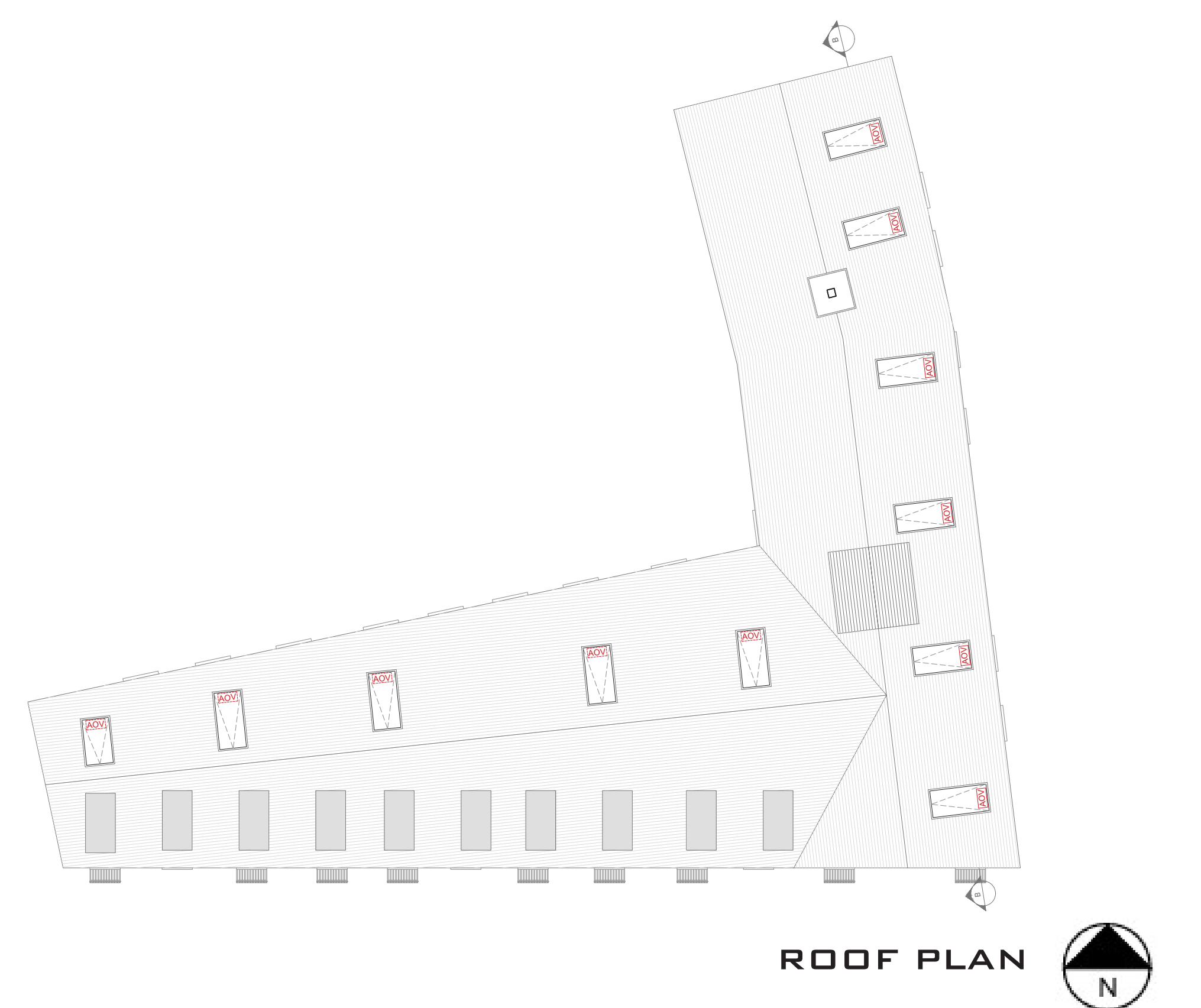

ROOF PLAN

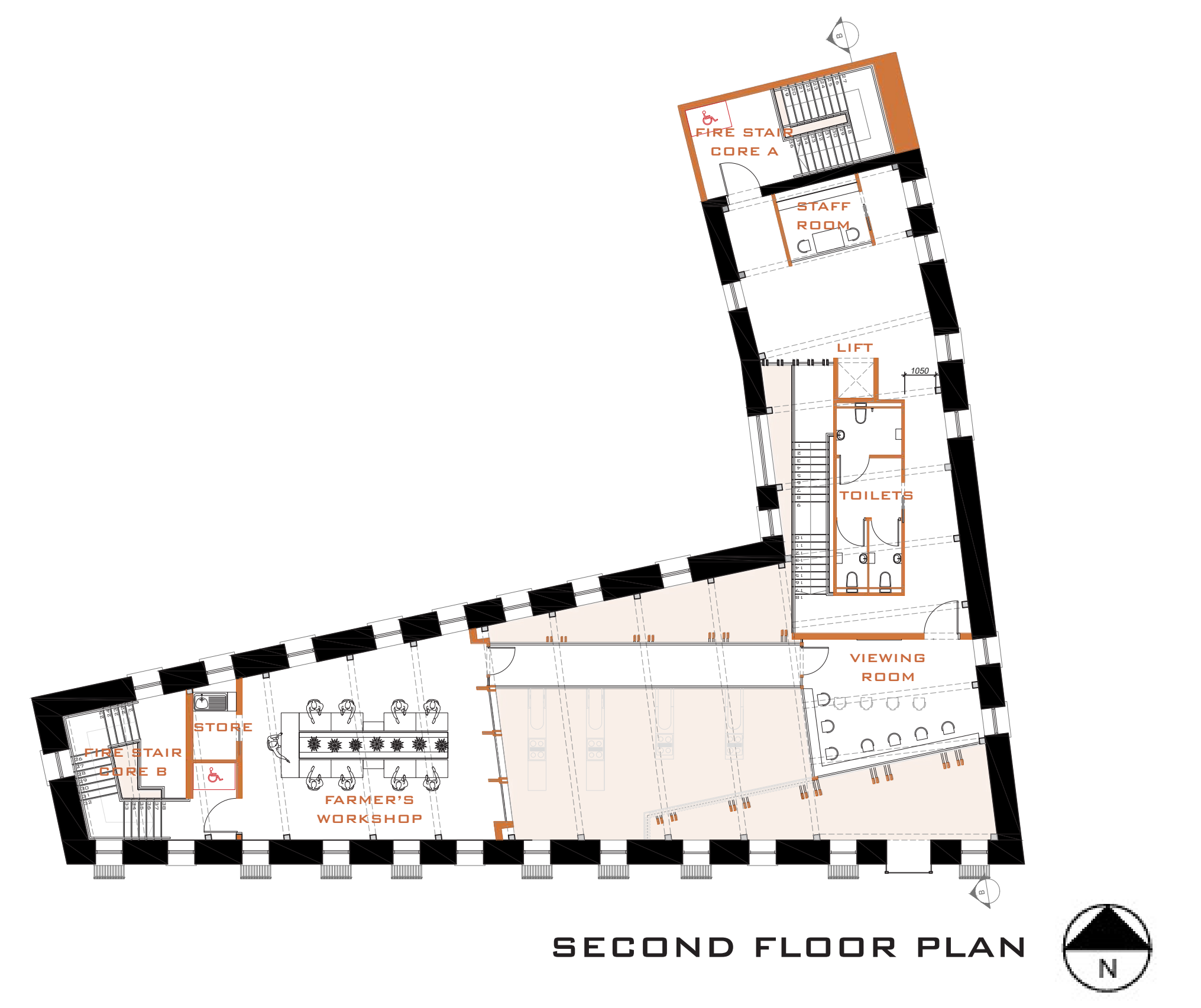

SECOND FLOOR PLAN

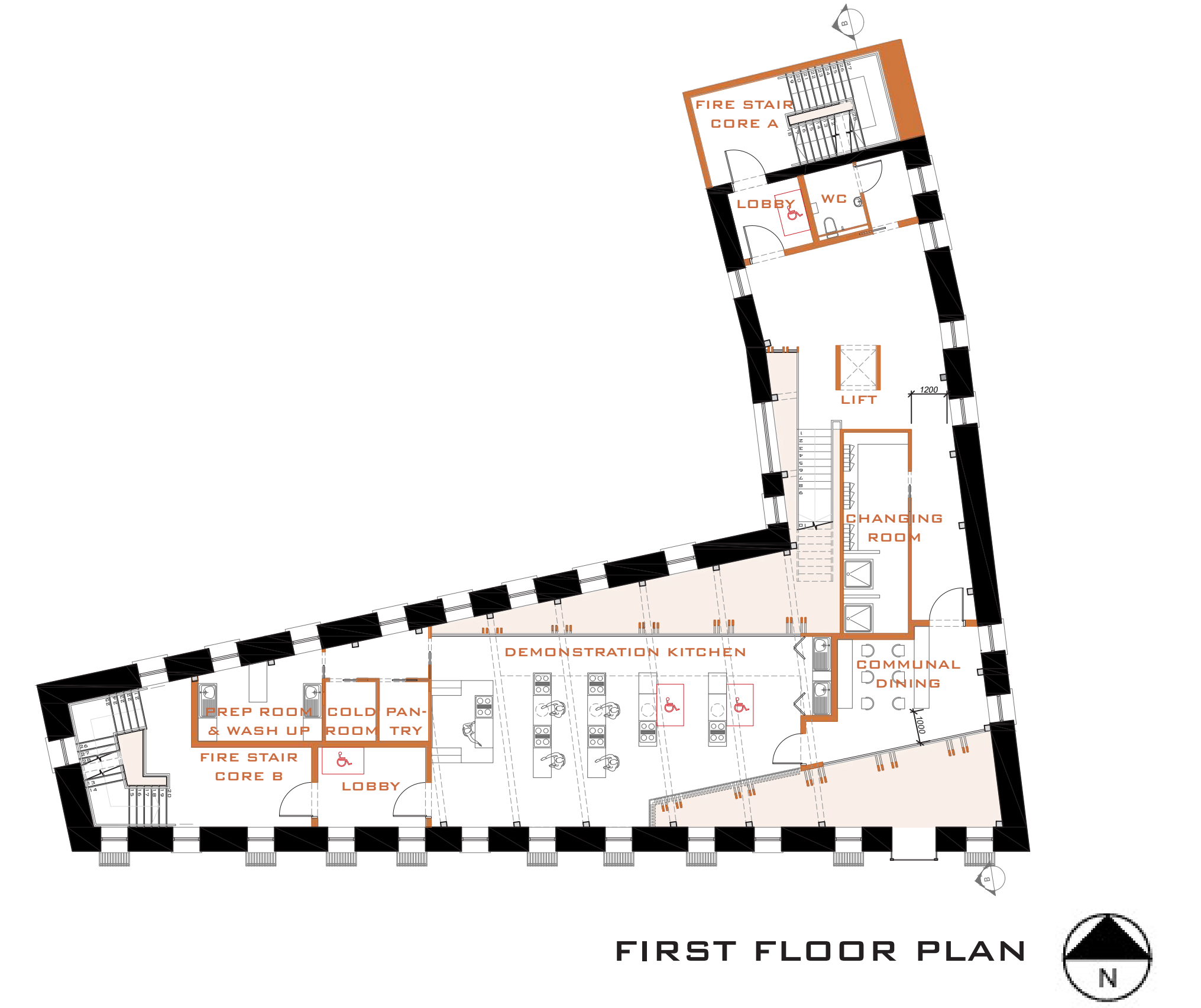

FIRST FLOOR PLAN

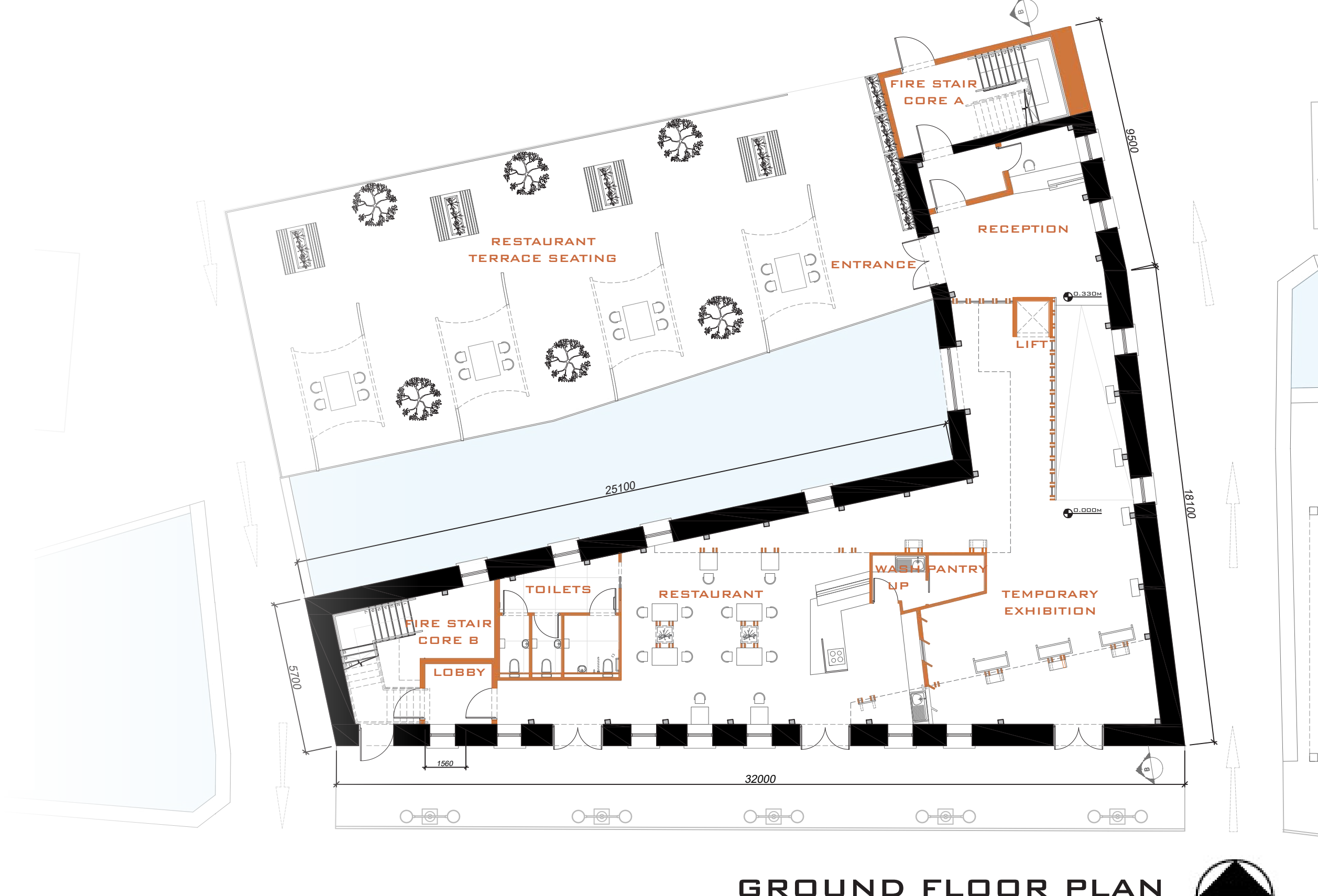

GROUND FLOOR PLAN

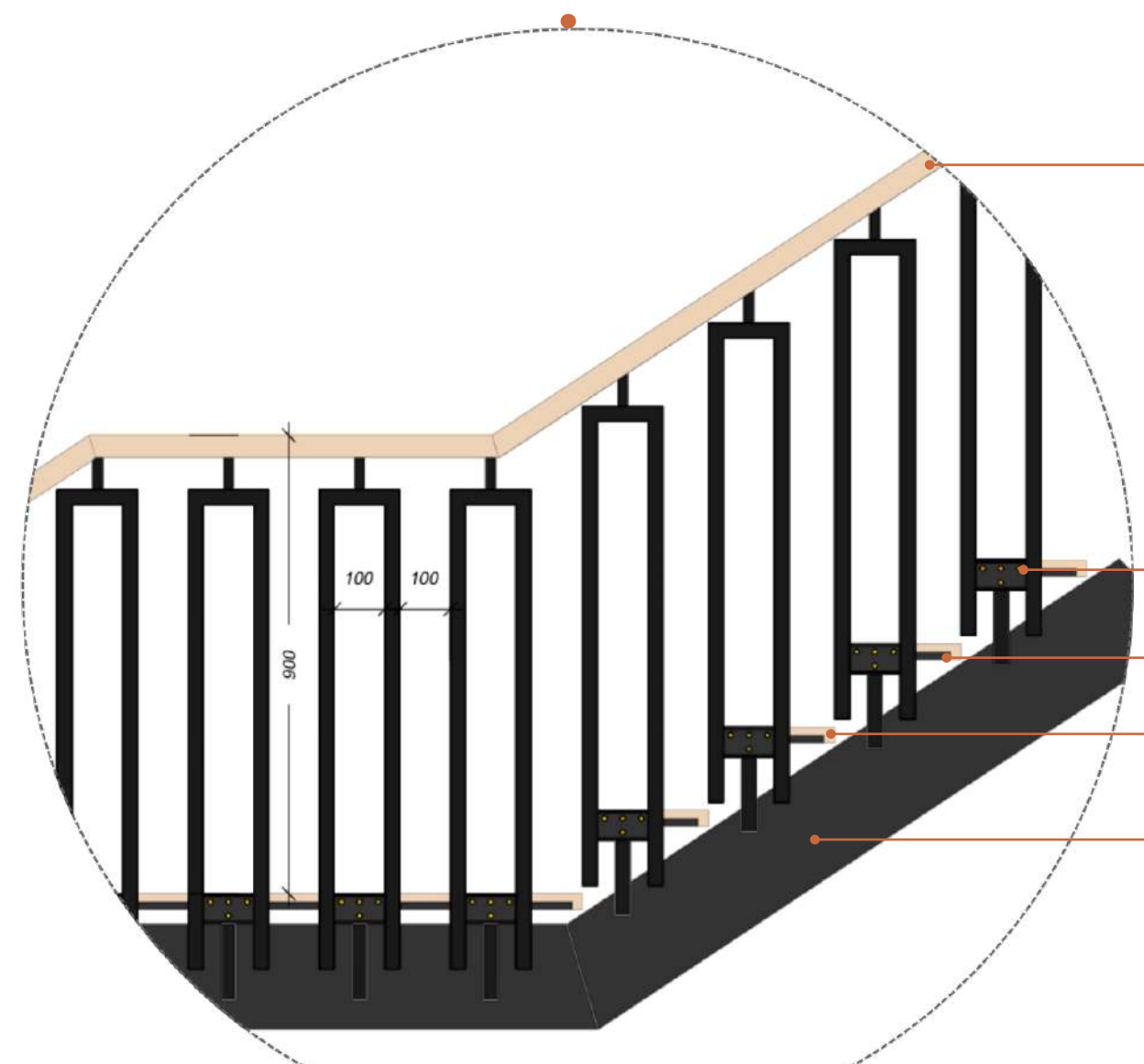

BALAUSTRADE DETAIL OF PART K STAIRS

- LIGHT OAK HANDRAIL
- BRASS BOLTS
- BLACK POWDERCOATED STEEL PLATE
- LIGHT OAK STEP
- BLACK POWDERCOATED STEEL PLATE

- DECORATIVE PENDENT LIGHT - TYPE 1
- DECORATIVE PENDENT LIGHT - TYPE 2
- DECORATIVE PENDENT LIGHT - TYPE 3
- TRACK LIGHTING
- SWITCH
- AIR CON GRILL
- FIRE EXIT INDICATOR SIGN
- EMERGENCY LIGHTING
- SMOKE/HEAT/CARBON MONOXIDE DETECTOR
- DOWNLIGHT

- DECORATIVE PERFORATED CEILING INSTALLATION
- PET ACOUSTIC PANEL
- CEILING HEIGHT
- KITCHEN EXHAUST FAN

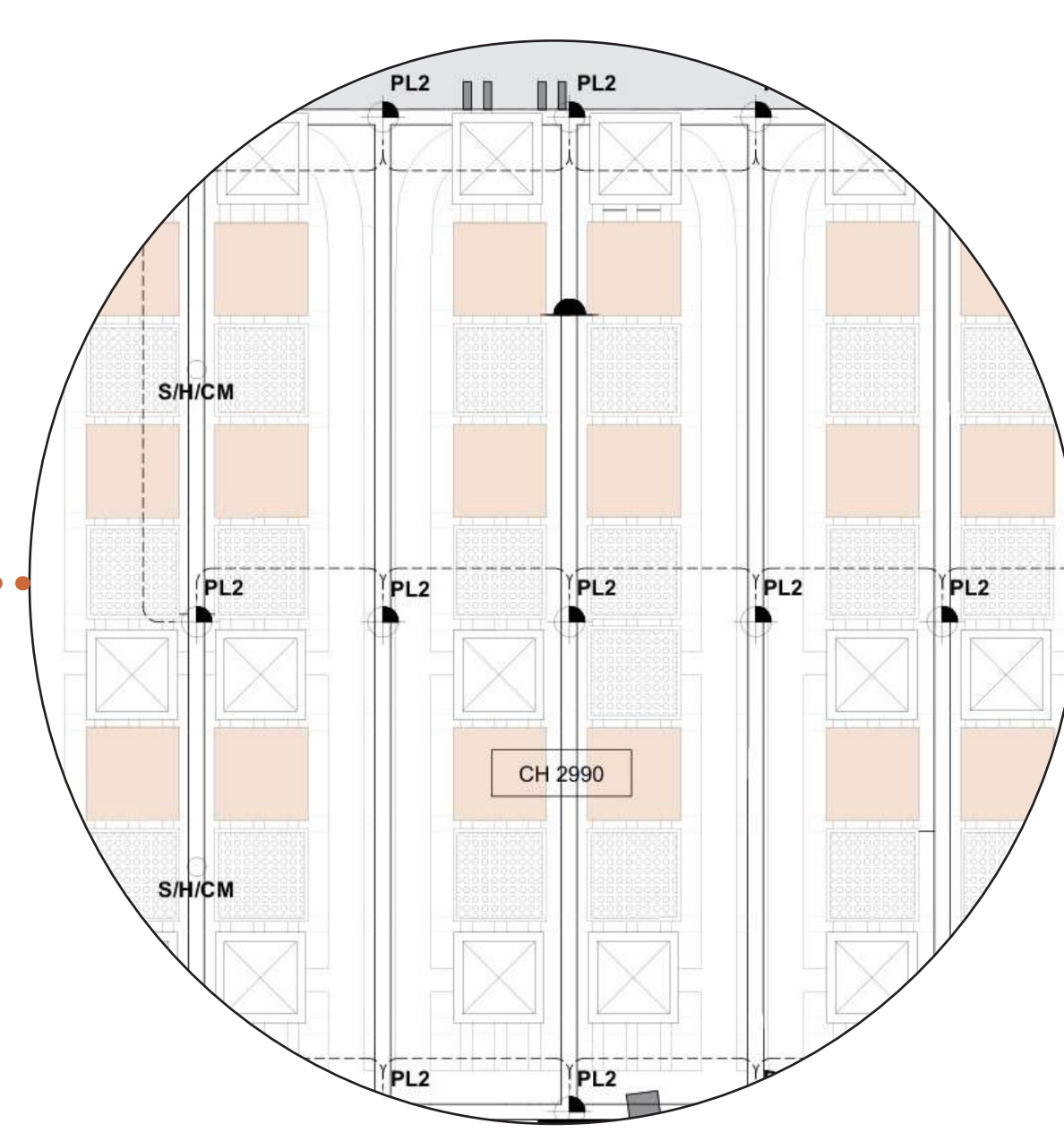

CEILING CLOSE UP

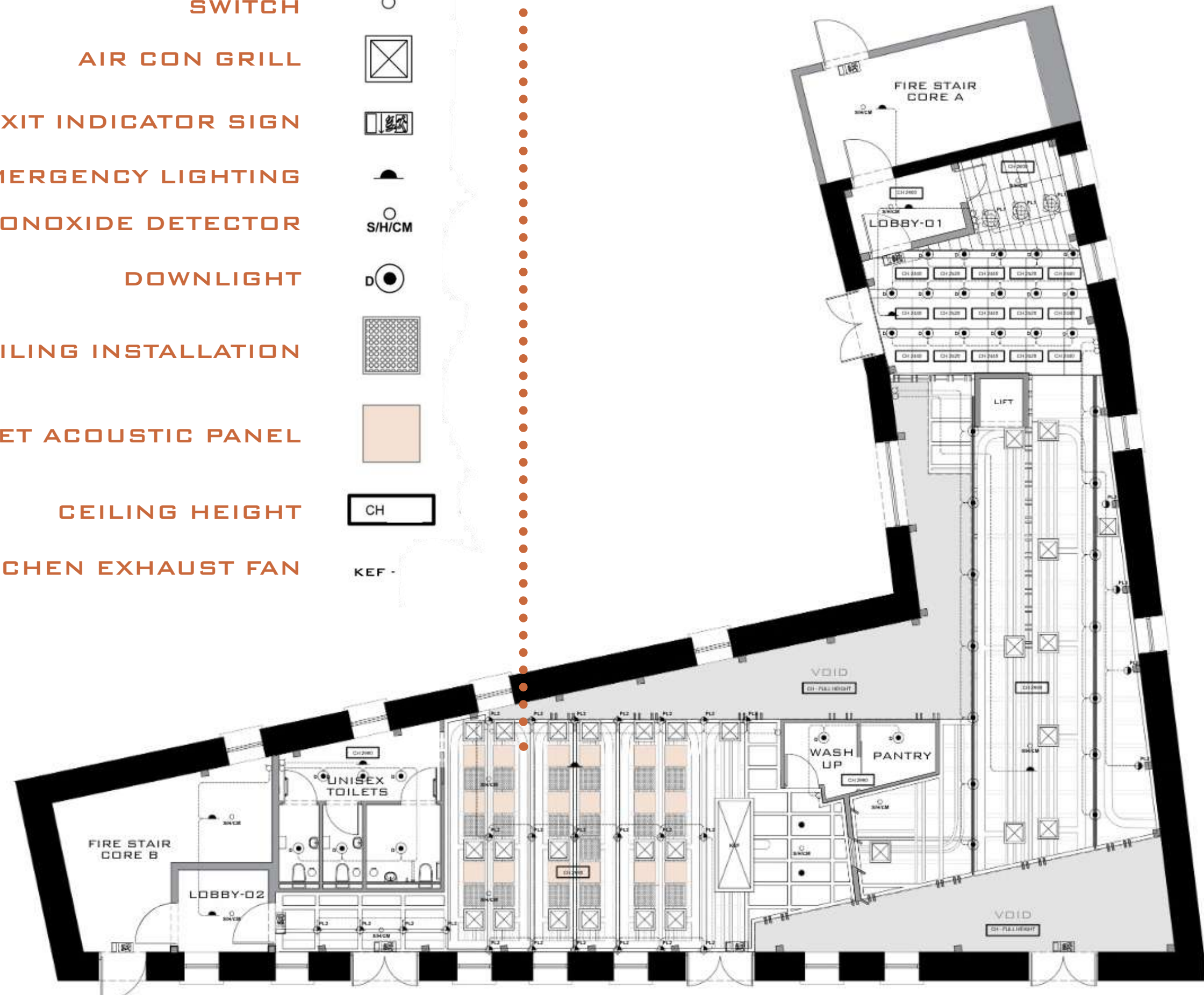

REFLECTIVE CEILING PLAN

FIRE STAIR CORE B HANDRAIL DETAIL

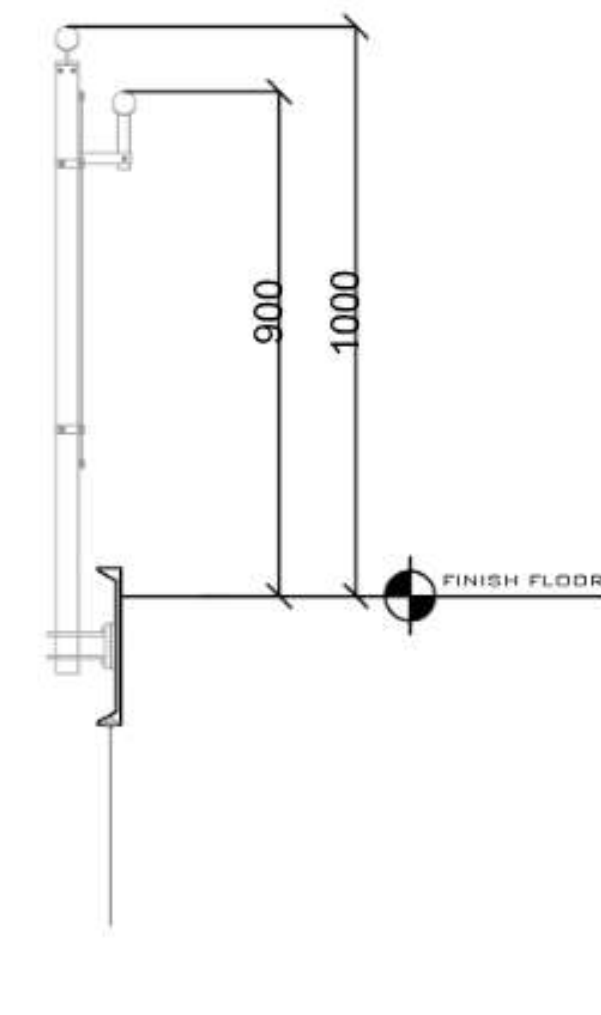
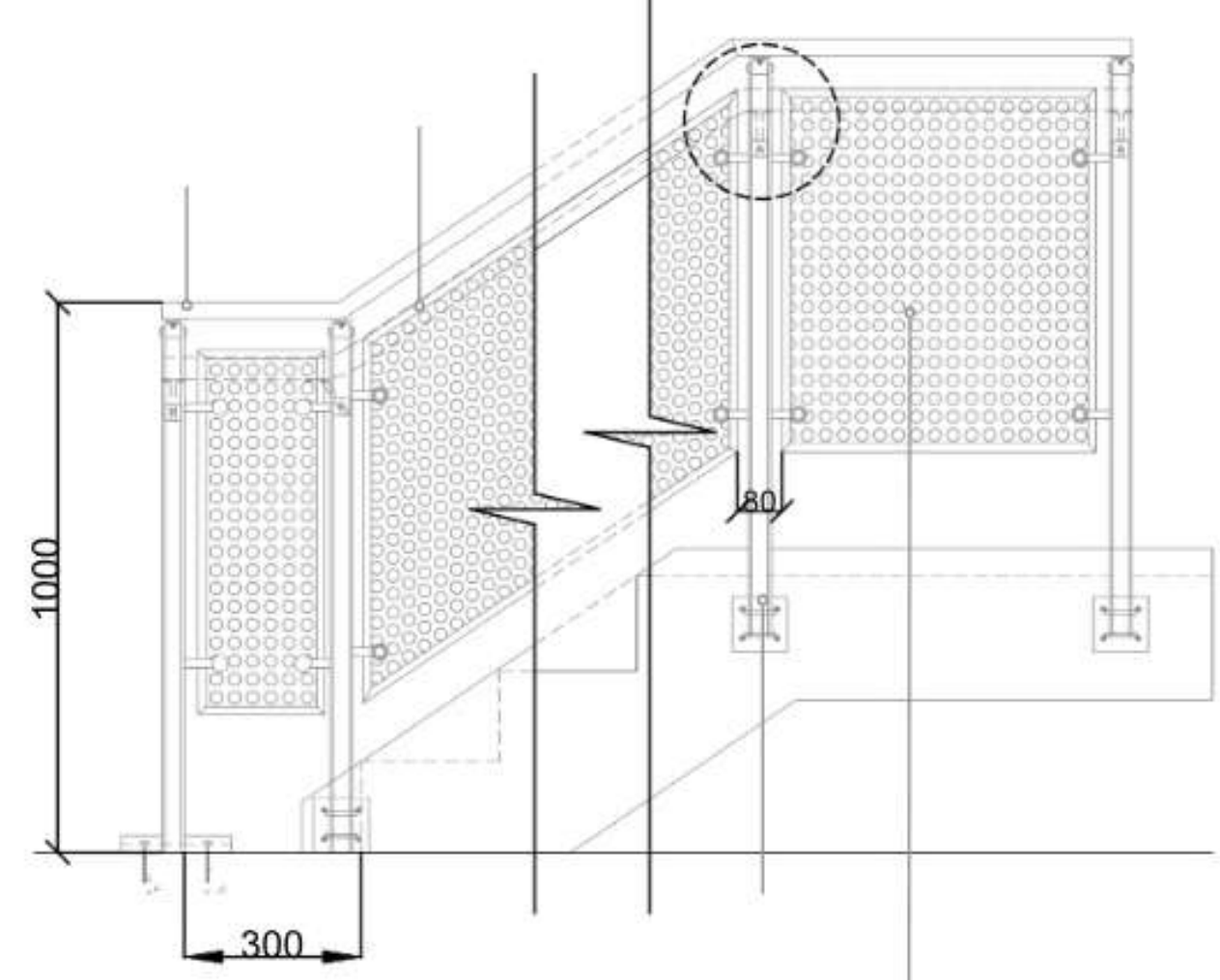

CONCRETE FLOOR FINISH LRV 40



ORANGE PERFORATED METAL

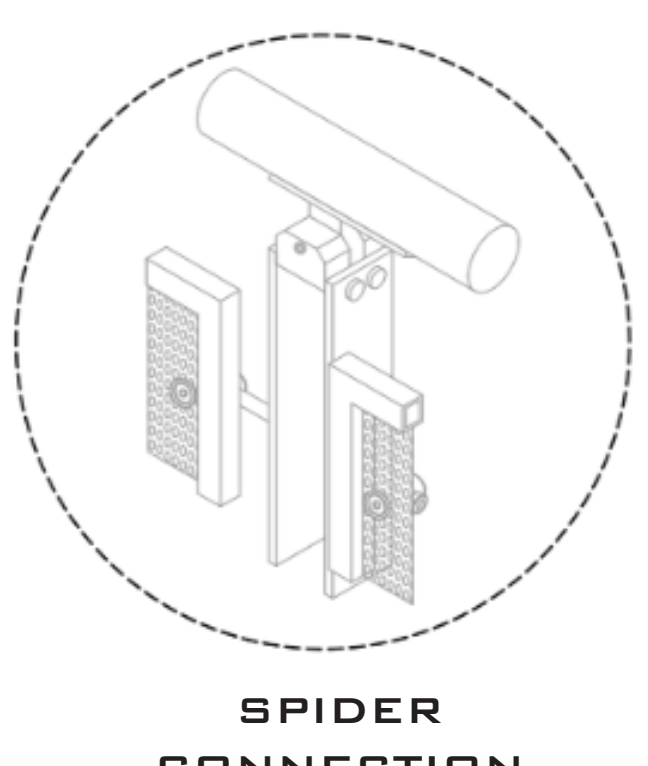

SPIDER CONNECTION

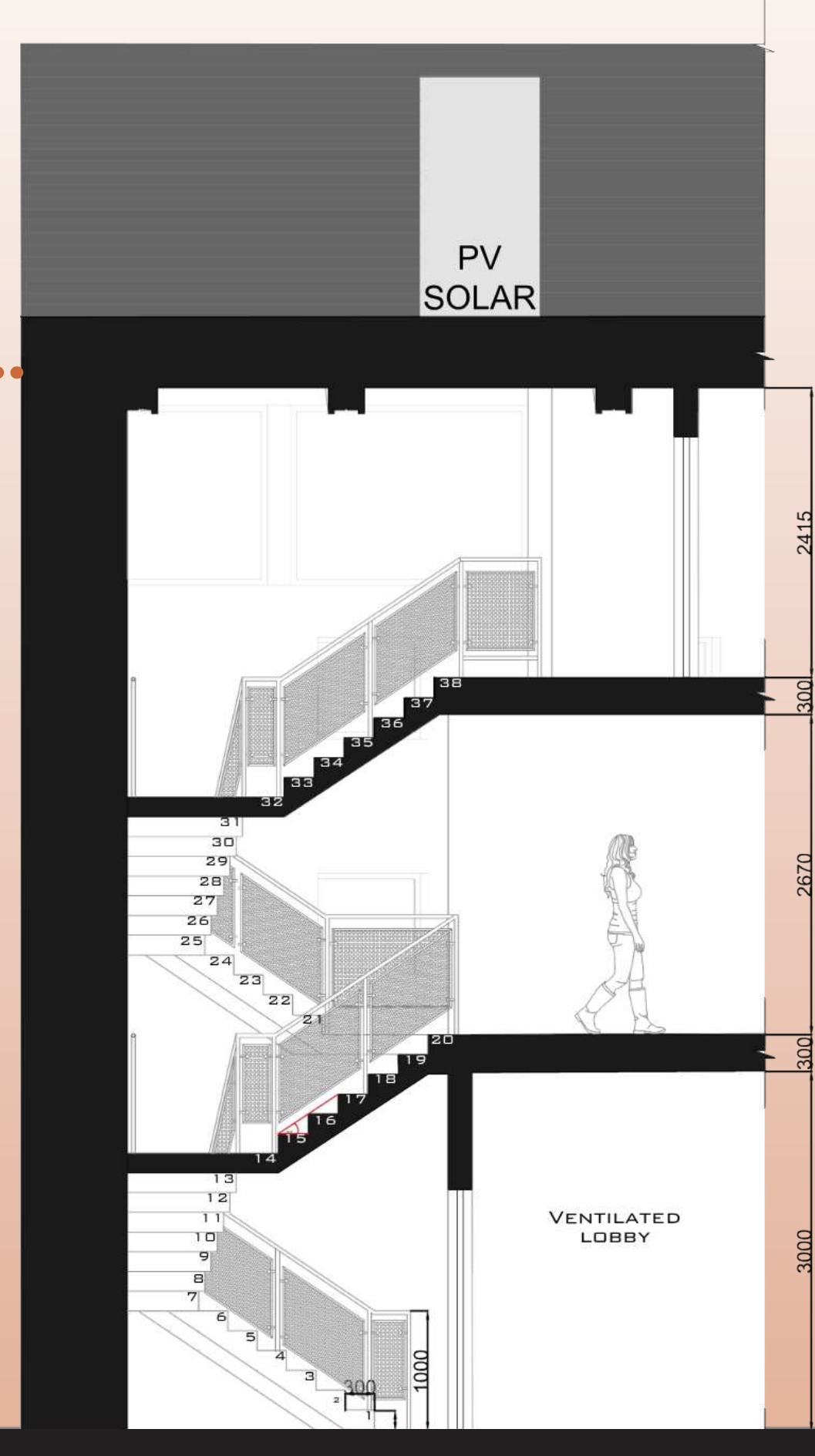

FIRE STAIR CORE B DETAIL

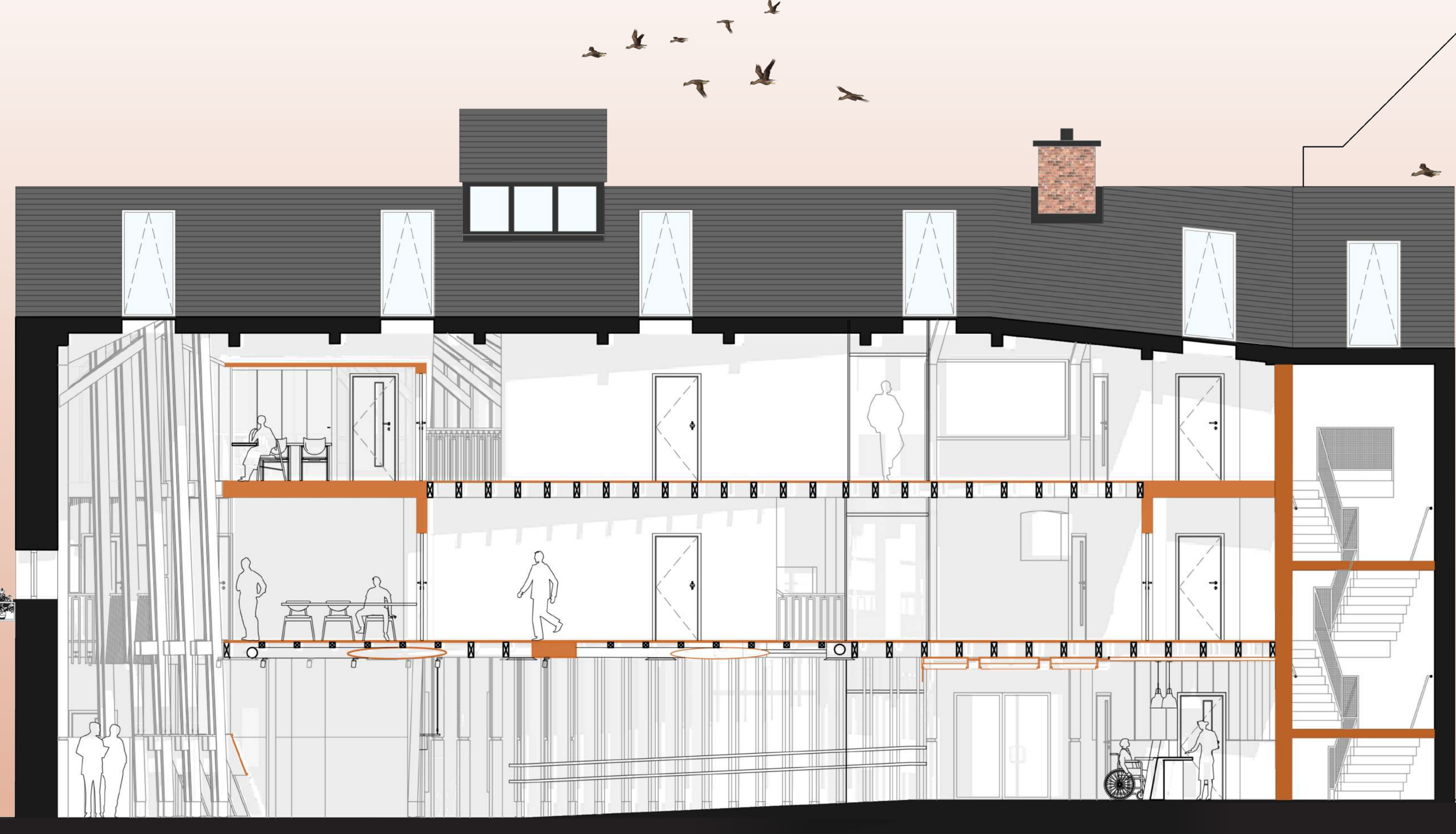

SECTION B.B