

CULTURAL NEXUS: THE NEW PORT OF BEIRUT

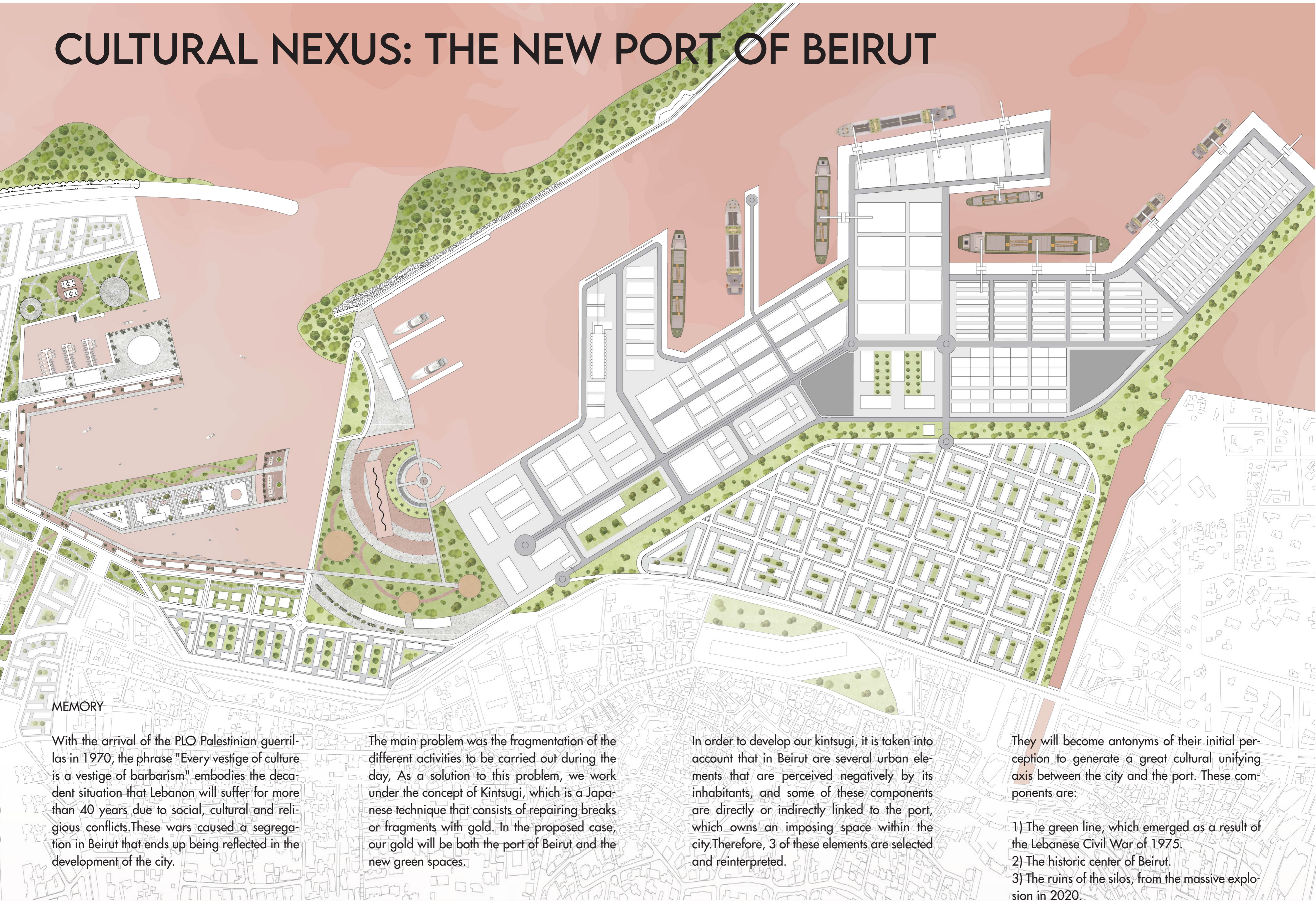

MEMORY

With the arrival of the PLO Palestinian guerrillas in 1970, the phrase "Every vestige of culture is a vestige of barbarism" embodies the decadent situation that Lebanon will suffer for more than 40 years due to social, cultural and religious conflicts. These wars caused a segregation in Beirut that ends up being reflected in the development of the city.

The main problem was the fragmentation of the different activities to be carried out during the day. As a solution to this problem, we work under the concept of Kintsugi, which is a Japanese technique that consists of repairing breaks or fragments with gold. In the proposed case, our gold will be both the port of Beirut and the new green spaces.

In order to develop our kintsugi, it is taken into account that in Beirut are several urban elements that are perceived negatively by its inhabitants, and some of these components are directly or indirectly linked to the port, which owns an imposing space within the city. Therefore, 3 of these elements are selected and reinterpreted.

They will become antonyms of their initial perception to generate a great cultural unifying axis between the city and the port. These components are:

- 1) The green line, which emerged as a result of the Lebanese Civil War of 1975.
- 2) The historic center of Beirut.
- 3) The ruins of the silos, from the massive explosion in 2020.

Problem: Fragmentation

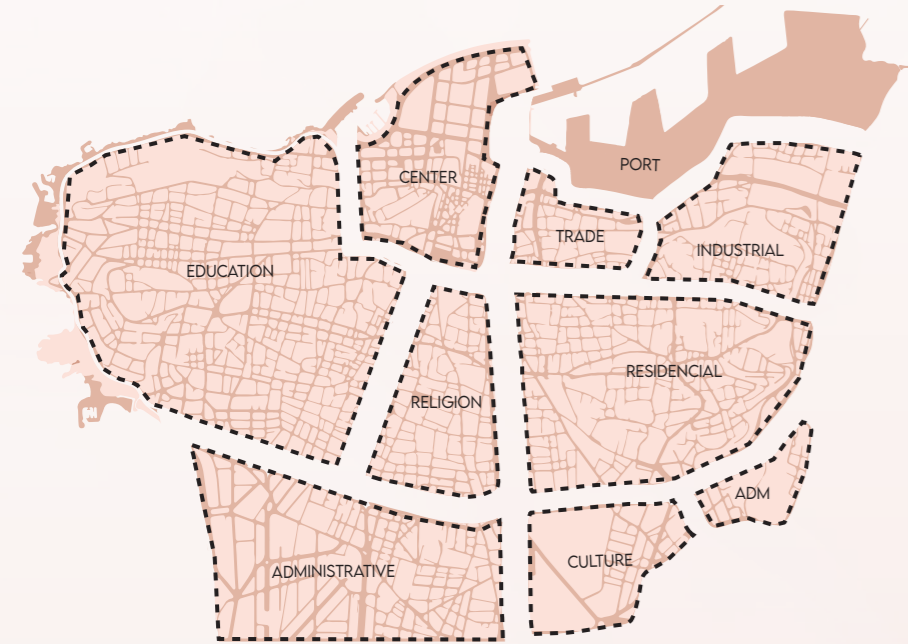

Solution: Kintsugi



Continuity



Key urban elements



COMMERCIAL BOULEVARD

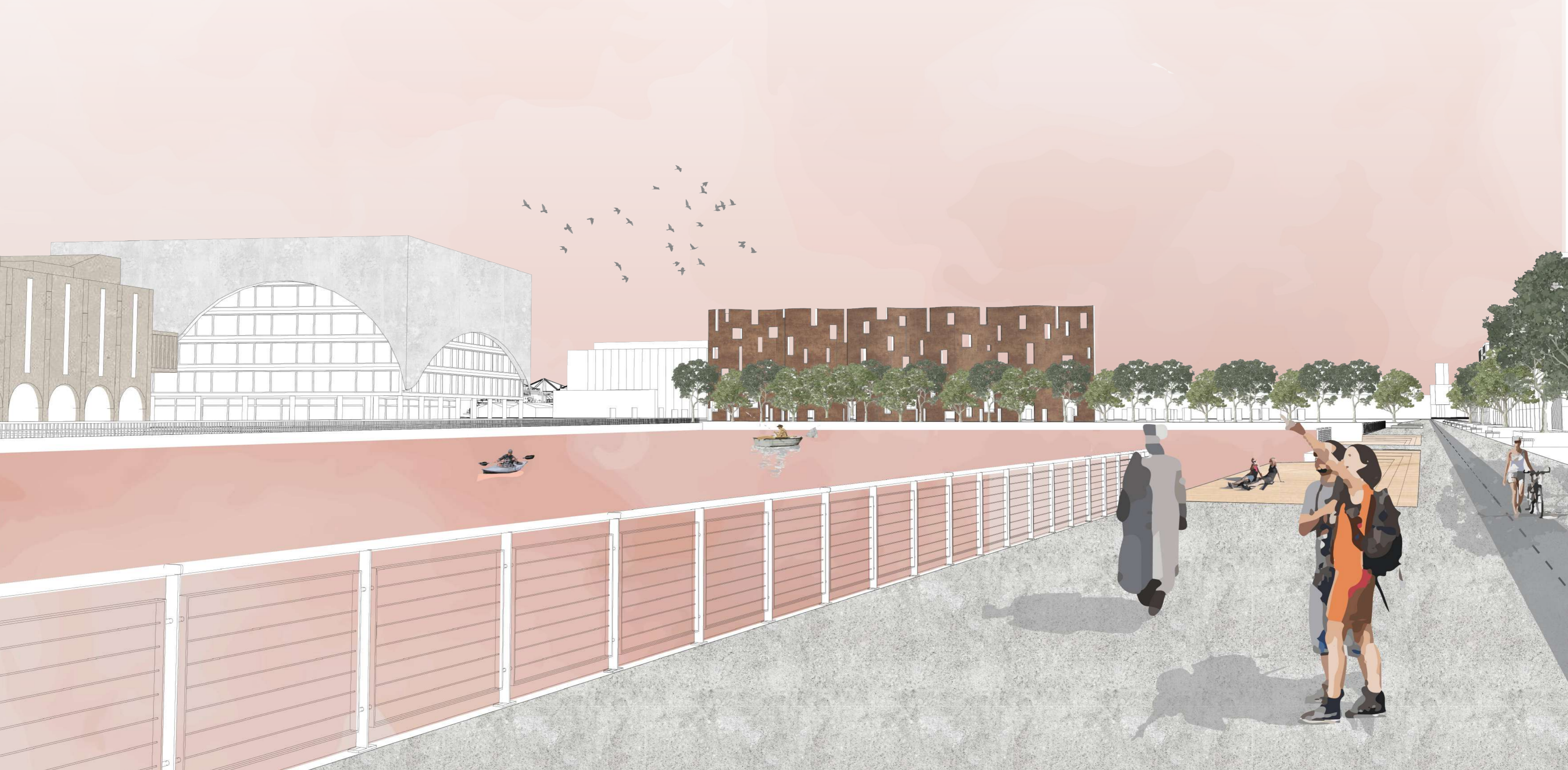

PORT: INDUSTRIAL ZONE



Legend

- 1.- Container Zone
- 2.- Free Zone
- 3.- Administration and narcotics
- 4.- Free container Zone
- 5.- Custom Control
- 6.- Cargo Zone
- 7.- New Silos
- 8.- Imported Cars
- 9.- Materials
- 10.- Passenger Terminal
- 11.- La Karantina industrial and residential zone

The Port

The port activities are located near the karantina area to enhance the semi-industrial character of the sector. In the same way, thinking about the user profile of the area (working families), it seeks to generate green spaces to connect citizens with their port and create natural spaces within the city. The port is organized by dividing it into 4 main areas, container zone, empty container zone, cargo zone and the administration, organizing the port with better road connections and distribution of diverse programs.

Relationship with the context



Principal Zonification

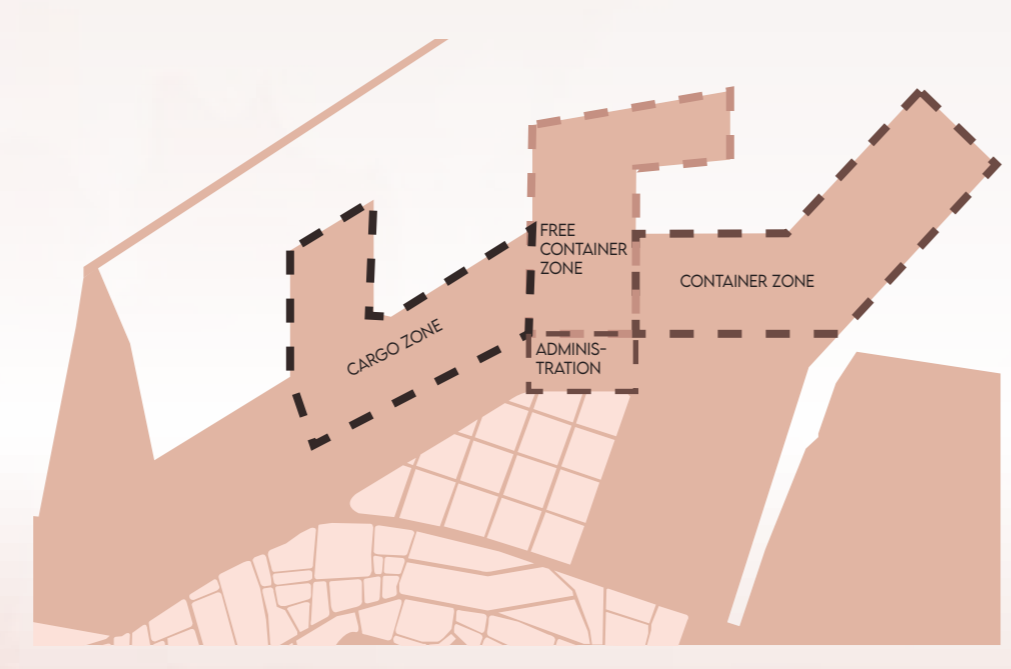

Green Line



New Border

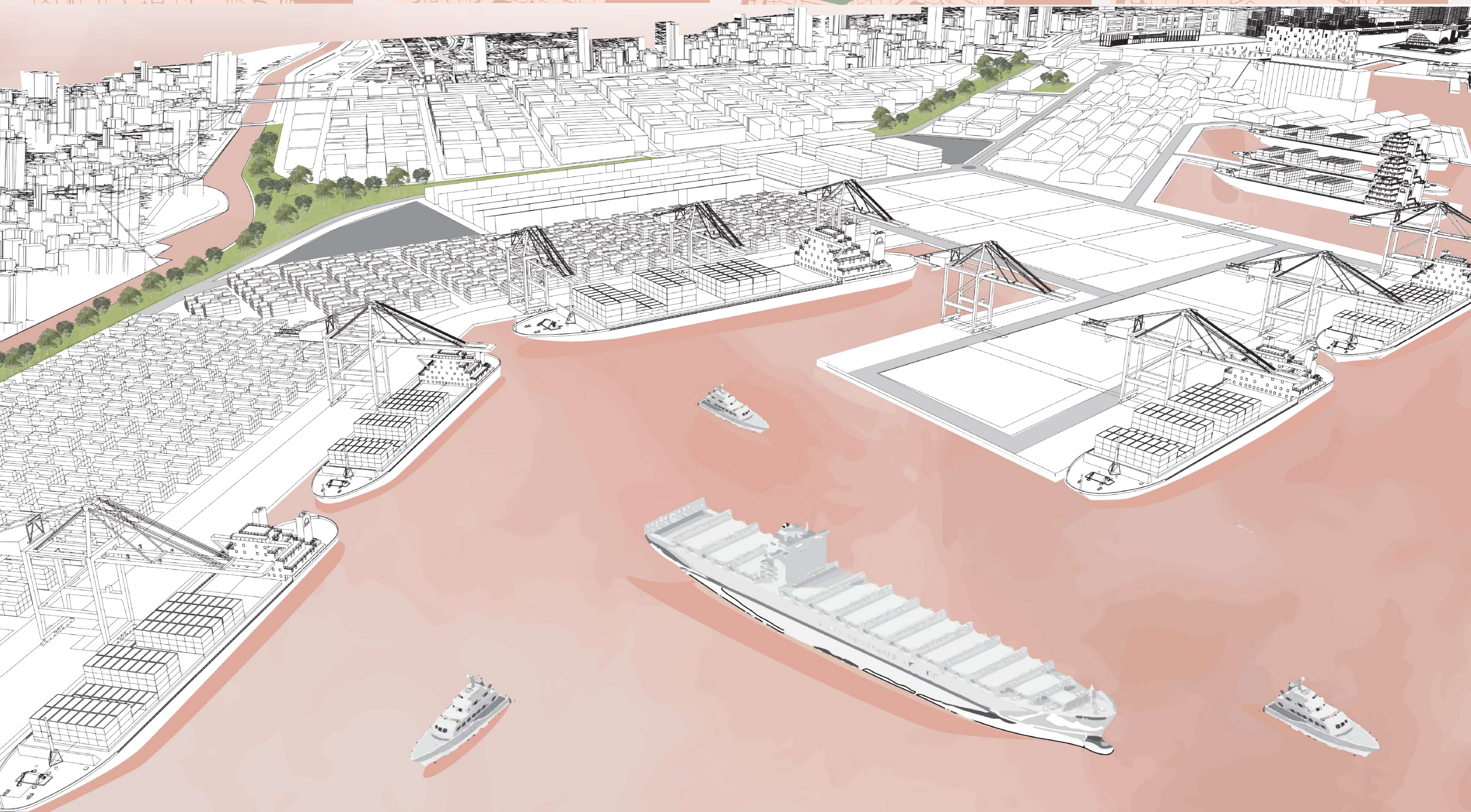
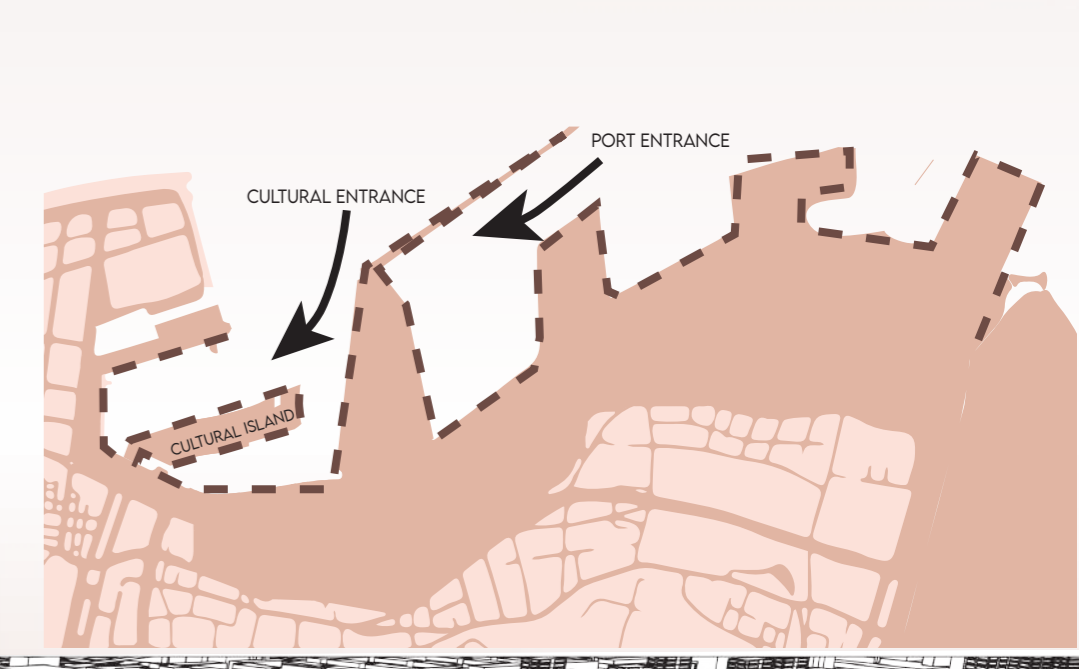

PORT: CULTURAL ZONE

Legend

- 1.- Memorial
- 2.- Museum and cultural center
- 3.- Silos lookout
- 4.- Acuarium
- 5.- Natural science museum
- 6.- Art museum
- 7.- Research center
- 8.- Linear park
- 9.- Financial area
- 10.- Souks boulevard
- 11.- Sport center
- 12.- Yate club
- 13.- Nautical School

Cultural Nexus

The green line is a strong reminder of segregation that crosses all of Beirut, it was an impassable space in times of war, so in its reinterpretation a nexus space is generated for the pedestrian that crosses the center of Beirut and connects the island proposal to paddle in a viewpoint where you can see the silo memorial.

The cultural and historical character of the center of Beirut is taken into account for the generation of cultural programs within the island. The expansion of culture and history towards the port generates an alignment with the silo memorial so that the user faces and looks at its history in a positive way.

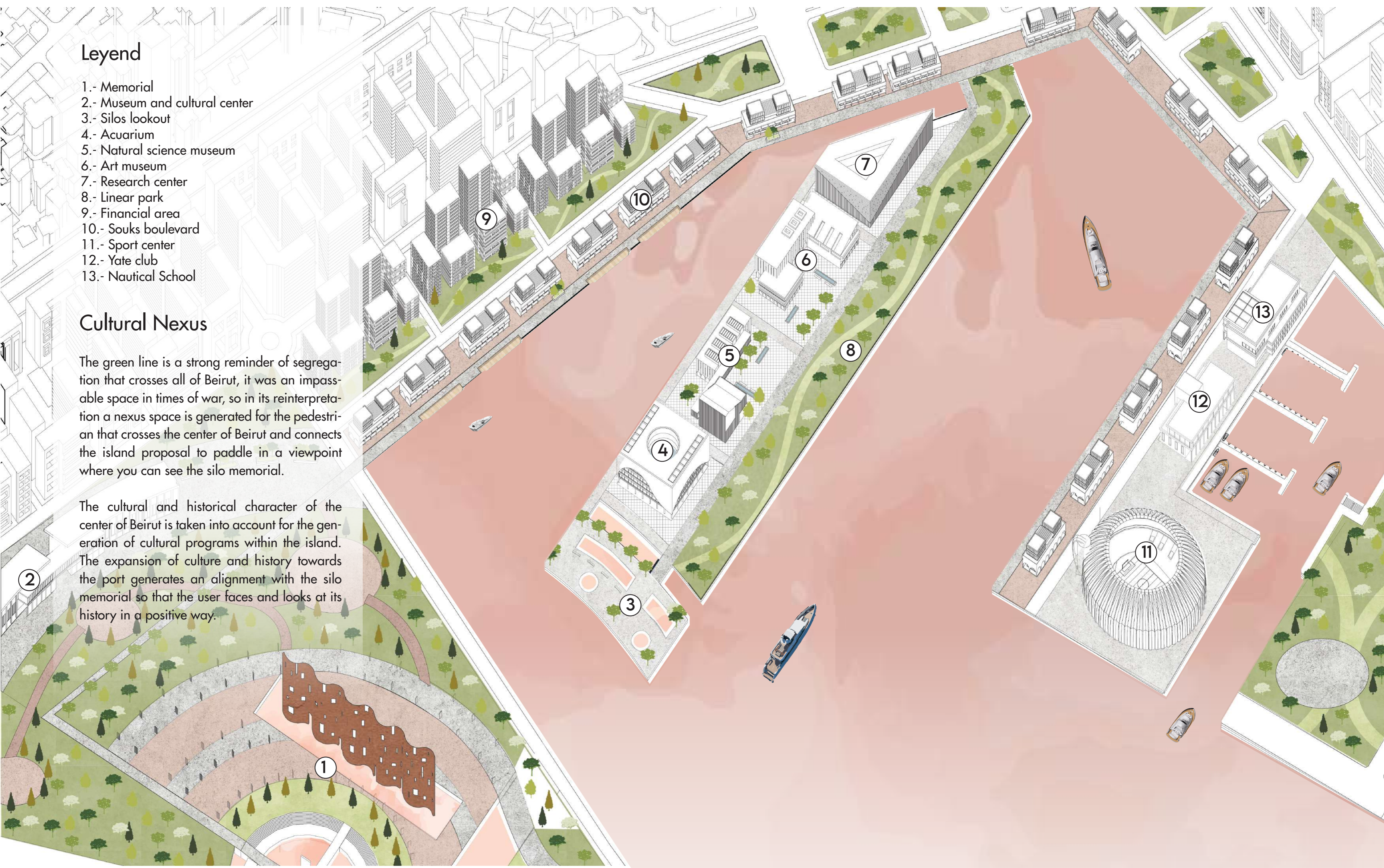

Relationship with the context



CULTURAL LINE

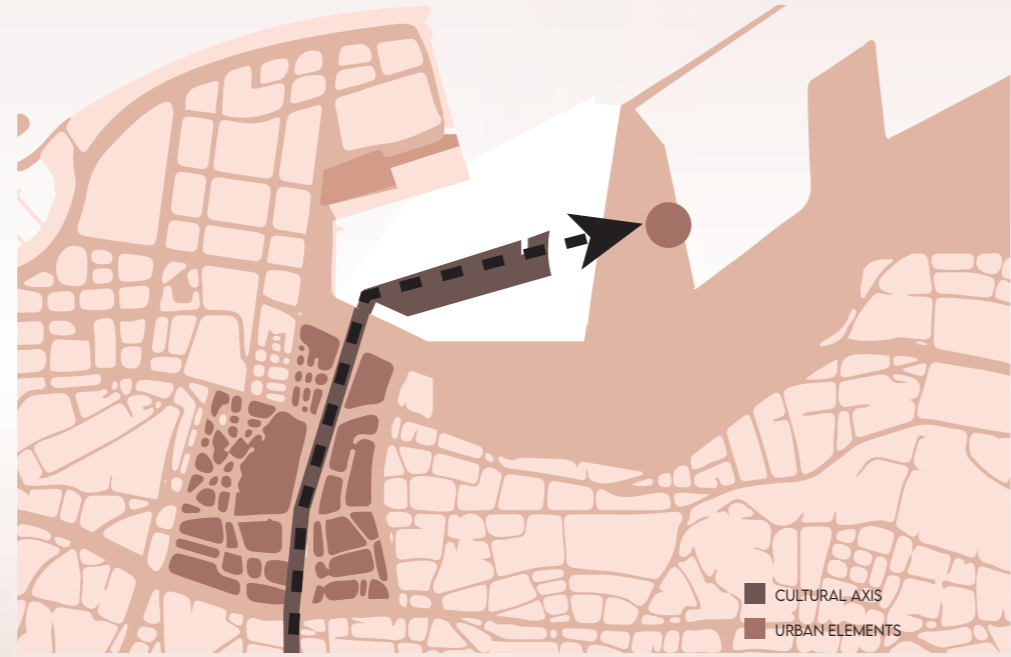

Burst

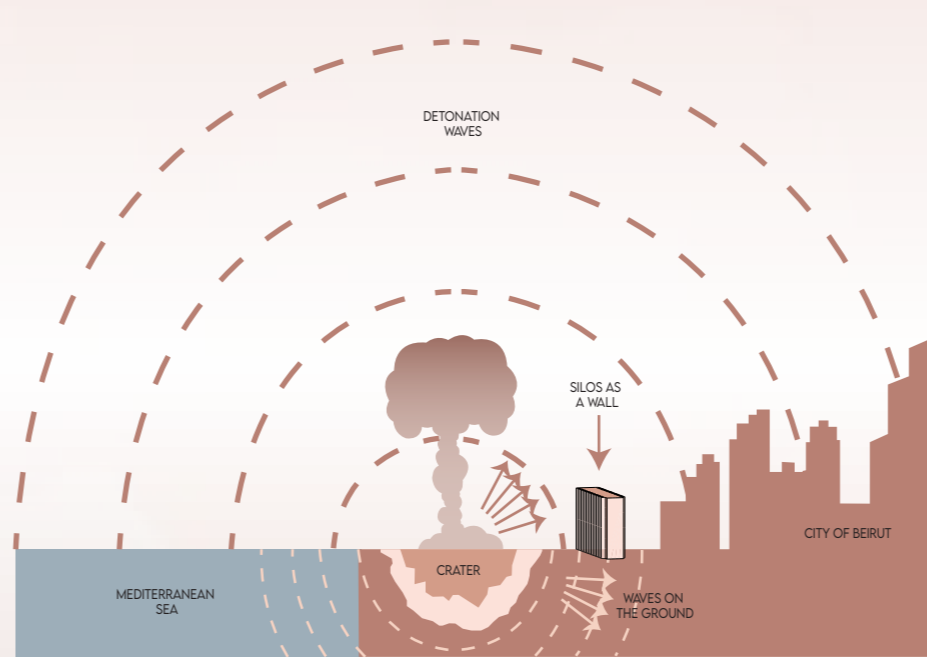

Aftermath

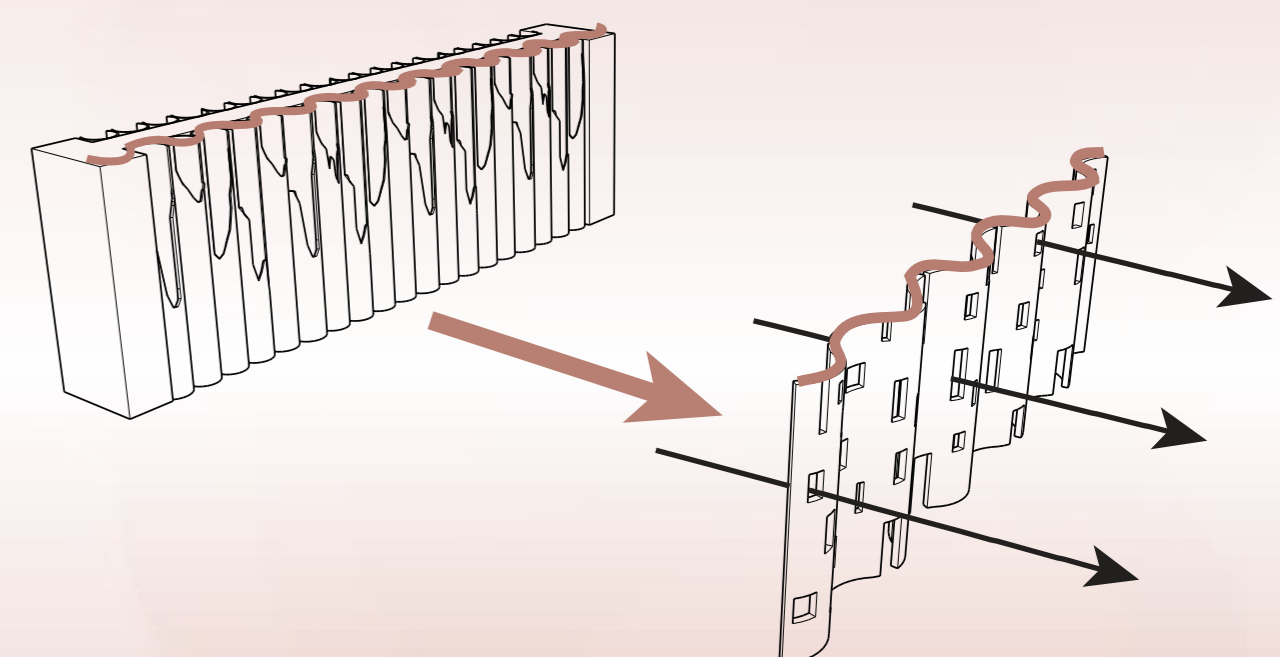

APPROACH CULTURAL VOLUMES



AQUARIUM

Traditional volume: Museum

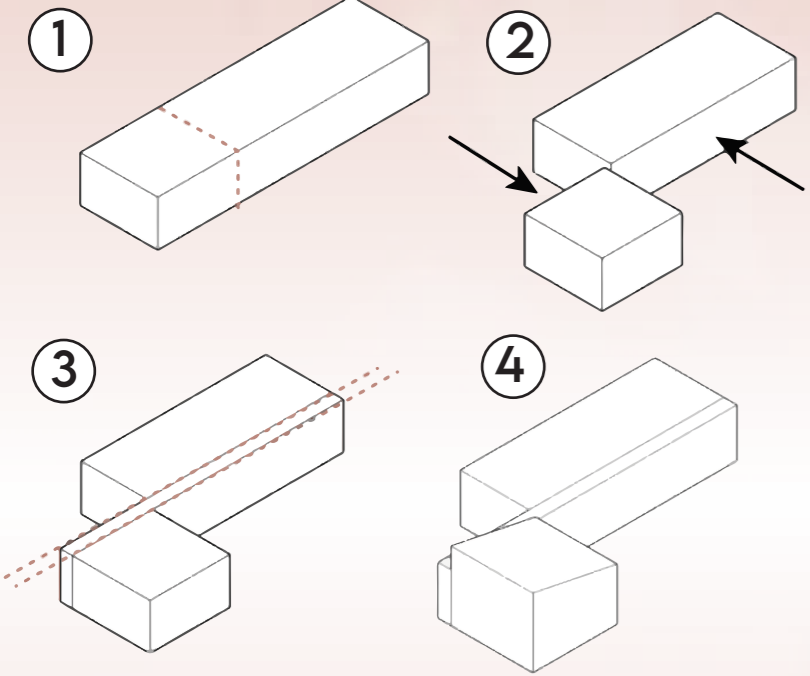

Modern volume: Acuarium

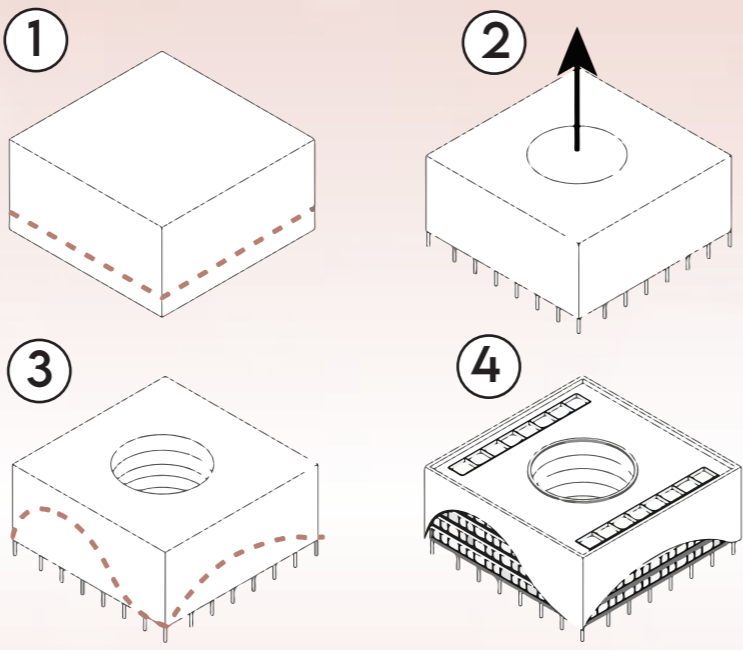

Section by volumes of interest



MUSEUM