

# Resilience: Beirut's Essence

## Reconfiguration Beirut's Port

### Mending Technique

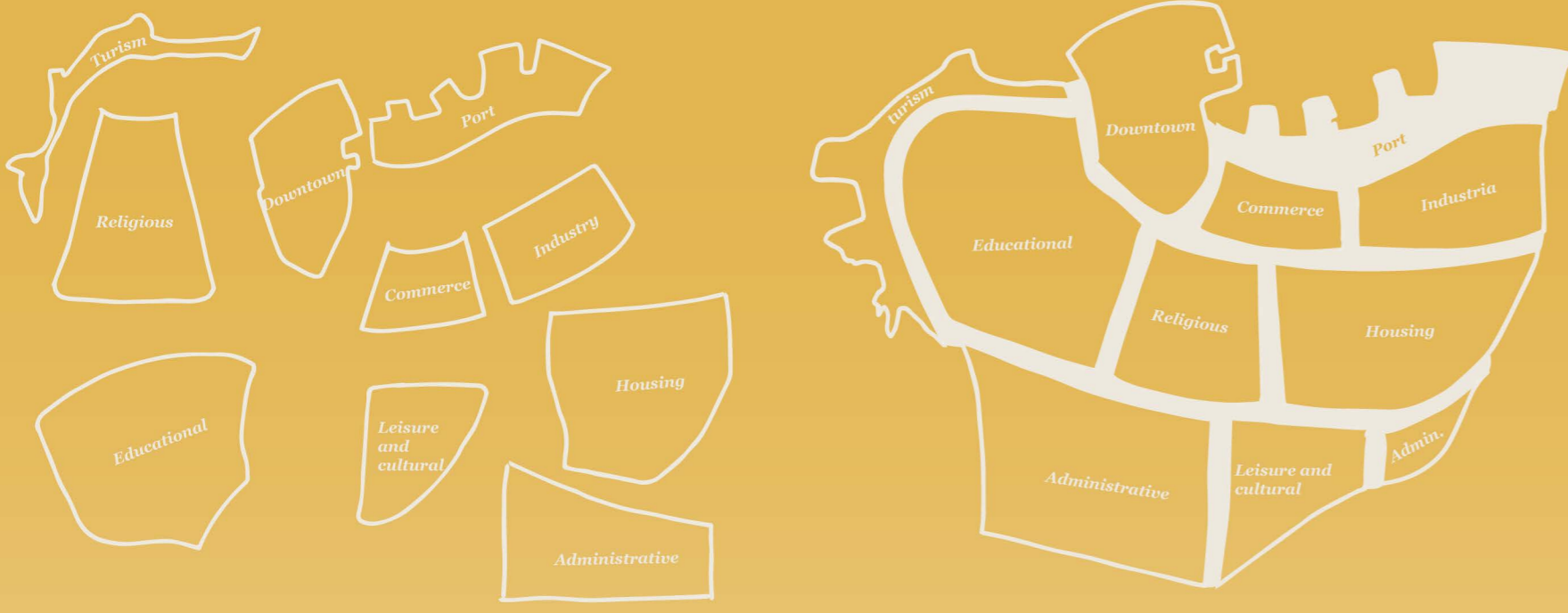

Beirut as a fragment of single pieces.

Reconnect Beirut by using the new port as a mending material that joins and enhances its urban form.



### Beirut's temporalities

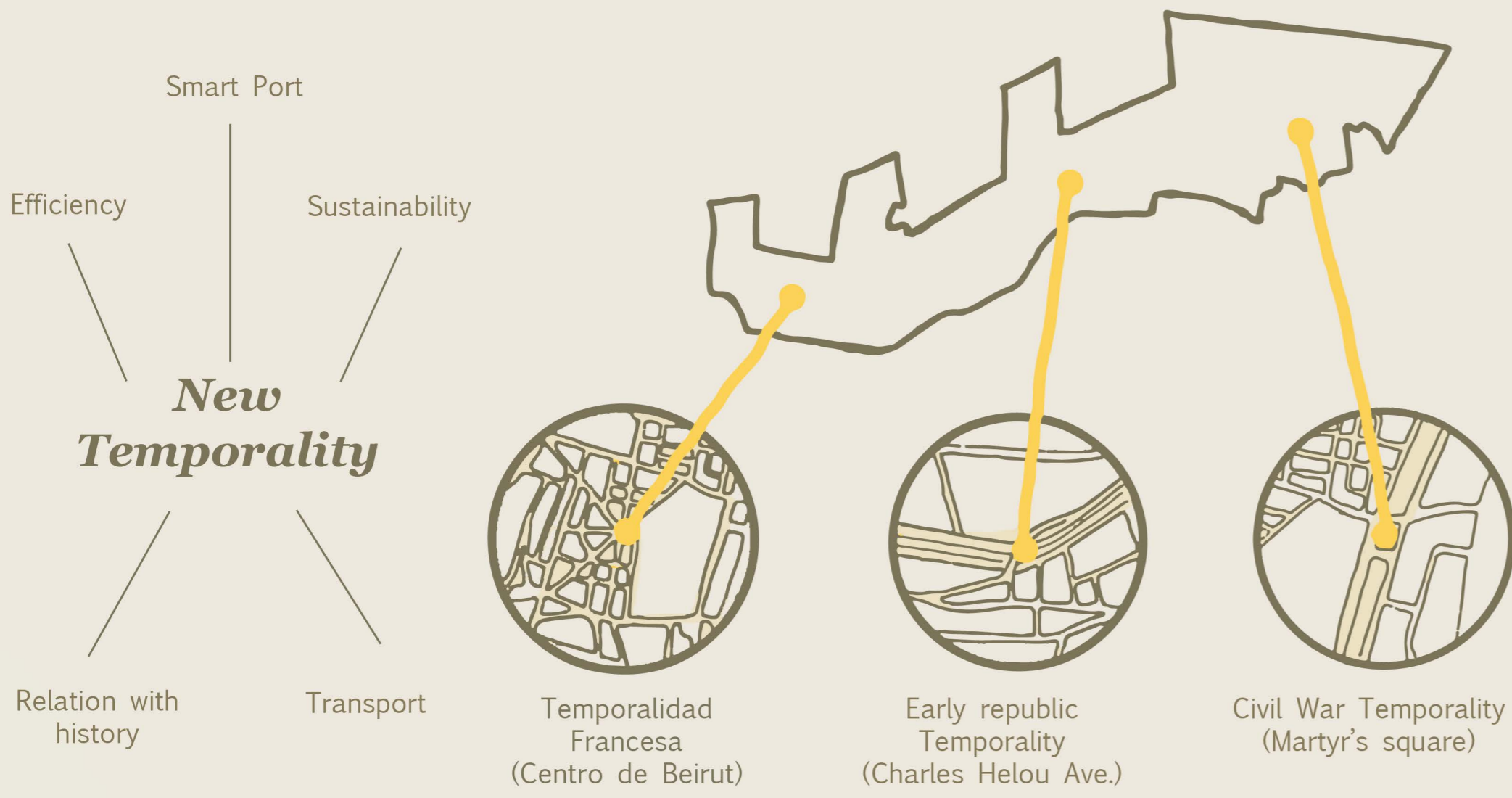

### Understanding Beirut

Beirut's long history, dating back more than 5,000 years, has seen the birth and death of various civilizations. Several temporalities have resulted from this process, where trading, war and violence have been recurrent. Consequently, this constant building and deconstructing of the city has forced its inhabitants to remain in a continuous state of displacement, which has not allowed them to generate a permanent and stable identity with their territory.

The reconfiguration of the port area is interpreted as a new temporality, constituting as an opportunity to generate recreational areas which allow to create and reinforce the bond that the citizens have with the city and with each other. In addition, the new monument-ruin of the former silos, marked by the strong explosion, is present in the collective memory for its permanence; thus this space is seen as an ideal area for cultural, social and leisure activities.

### Mending Technique: Resilience opportunity

Beirut is understood as a fragmented space through time, whose urban morphology has resulted from its resilience culture (building and deconstructing). The new port proposal will act as a unifier of all these pieces.

### Approach to linear park



# Approach to the Port Zone

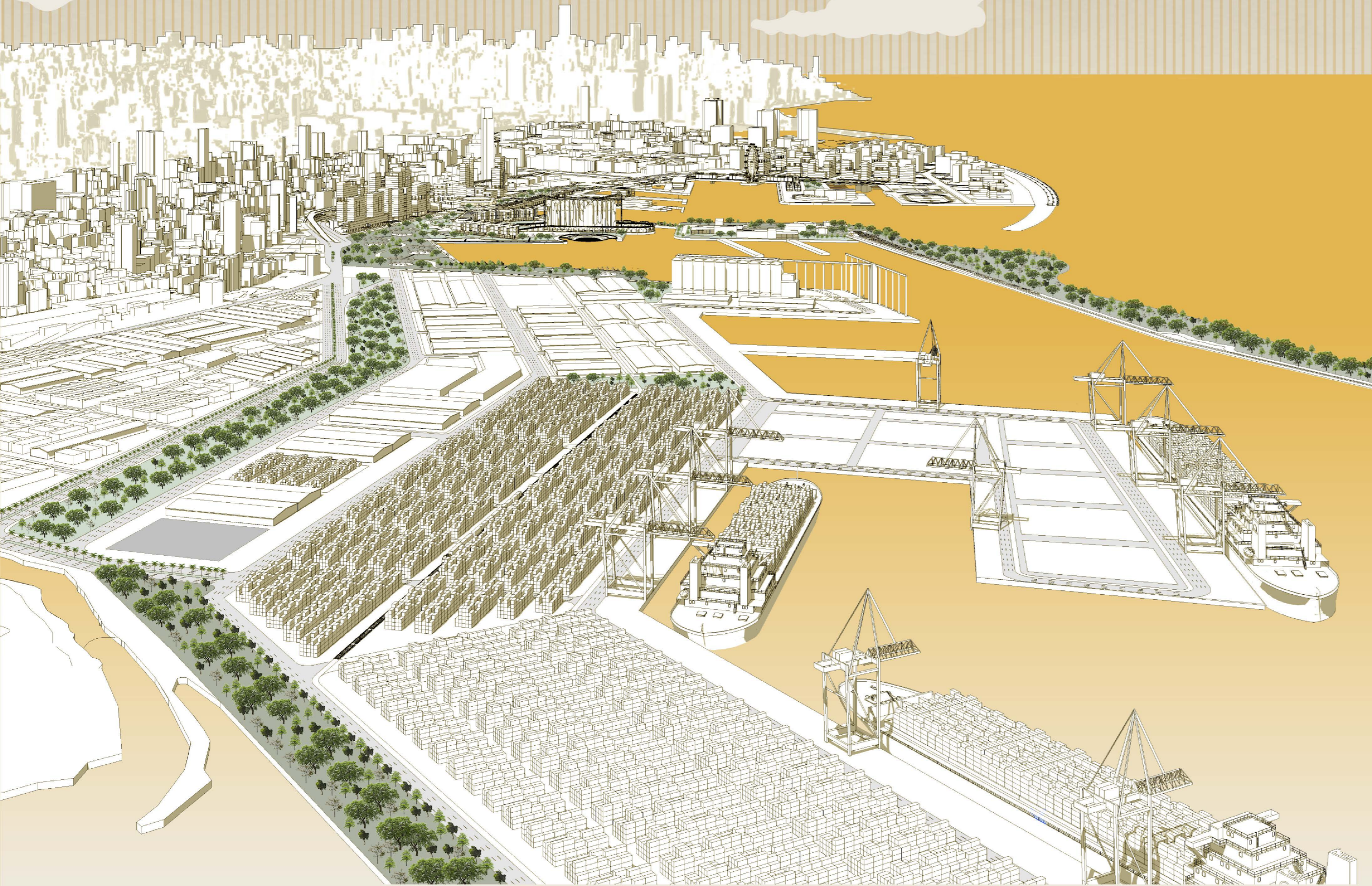

# Territorial intervention

## Port morphology

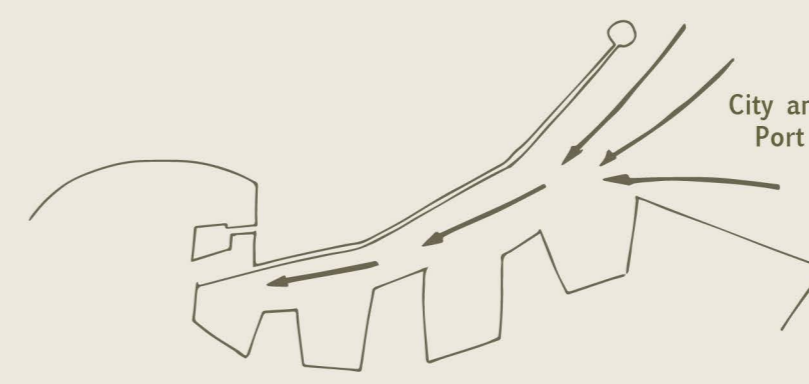

Single entrance for port and city activities.

## Proposed morphology

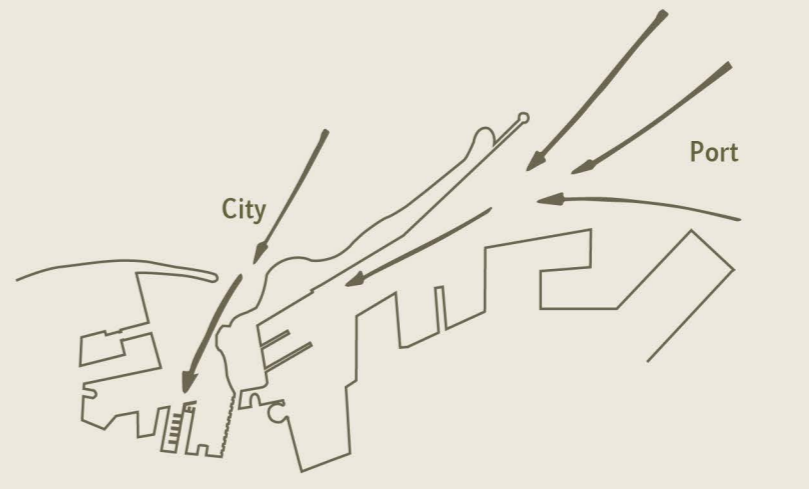

Dam separation to distinguish between port and city activities.

## Port distribution

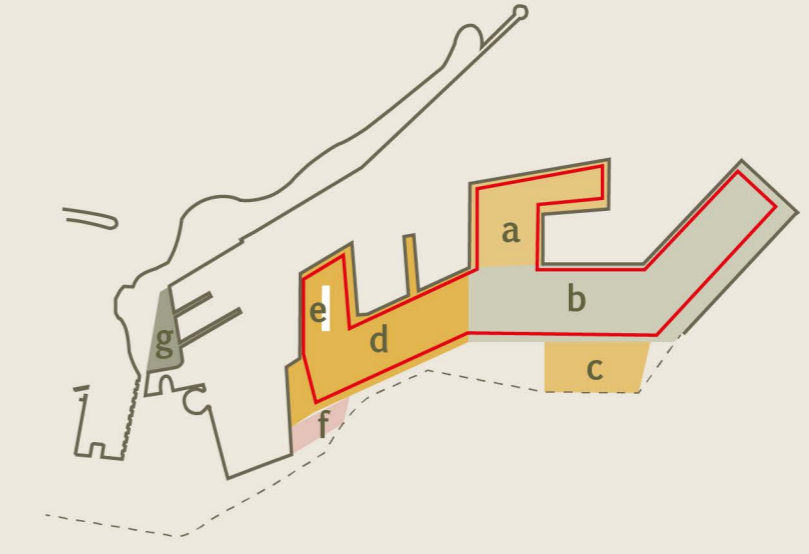

- a) Empty container zone
- b) Container zone
- c) Free zone
- d) Conventional cargo zone
- e) Silos Building
- f) Administrative area
- g) Passenger terminal
- Train tracks

# Recreational area

- a. Passenger terminal
- b. Botanical garden
- c. Resilience (Silos Monument-ruin)
- d. Museum
- e. Cultural Center
- f. Nautical School
- g. Amphitheater
- h. Administrative area
- i. Financial area
- j. Ferry terminal
- k. Aquarium
- l. Marine Investigation Building
- m. Souks
- n. Sports area
- o. Multipurpose auditorium
- p. Linear park
- q. Amusement park

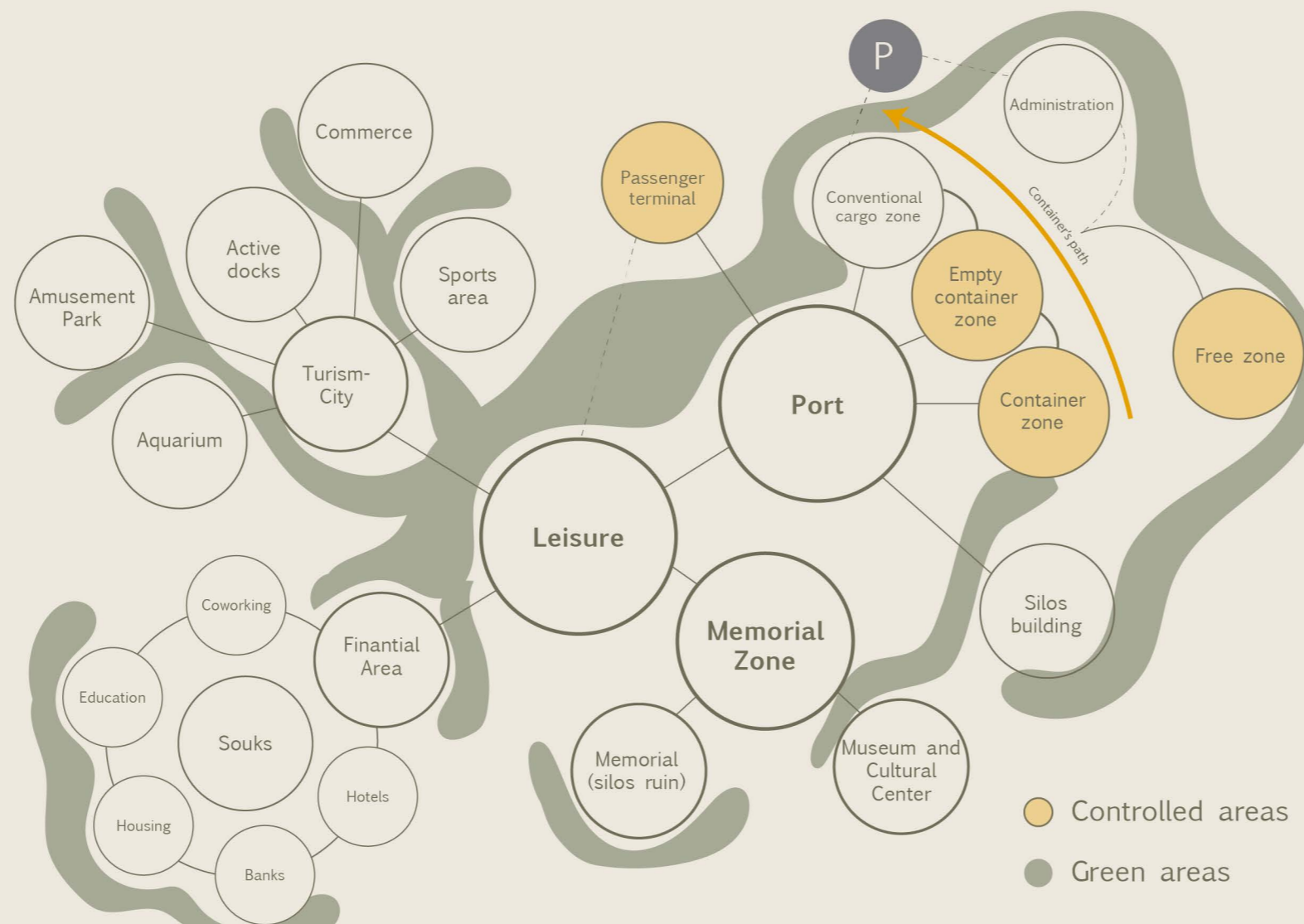

## City Area - Port Area (Parti)

The proposal divides the intervention zone into two main areas. First, an area related to the city where leisure, commerce, housing, administrative and cultural programs will be developed. Due to its proximity to the city, part of the harbor is understood as artisanal, therefore, a change in scale is needed. It will now establish a better relationship with the pedestrians. The second main area of the proposal is its functional zone where Port activities will continue. This zone manifests itself as an opportunity to improve and apply more sustainable ideas.

## Memorial zone

Within the recreational zone, a special importance is given to the area of the ruin as a fundamental axis that marks the geometry in plan and section of the space and its borders. The green area is a permanent element that integrates both port and city zones, acting as a unifier. This area is not out of its context because, like the geometry described above, its composition follows the monument-ruin's main axis.

## Monument-ruin concept (Resilience)



## Memorial zone intervention

### Base form

Initial volume (linear block typology). It is divided in two main areas: the museum (a) and the cultural center (b).

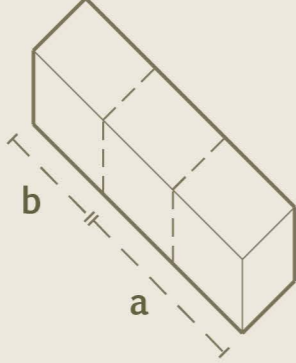

### Module Division

Creation of the "living street" concept, and the use of the free plan to strengthen visual relations.

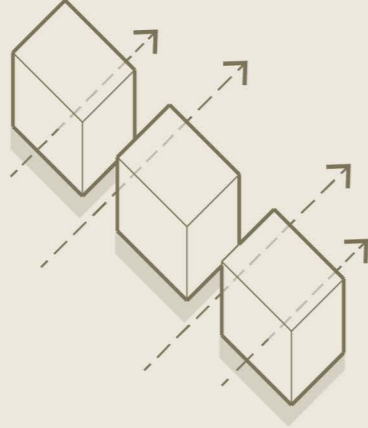

### Composition

Main axes that start from important elements like the monument-ruin (silos) and the initial place of the explosion to compose the proposal.

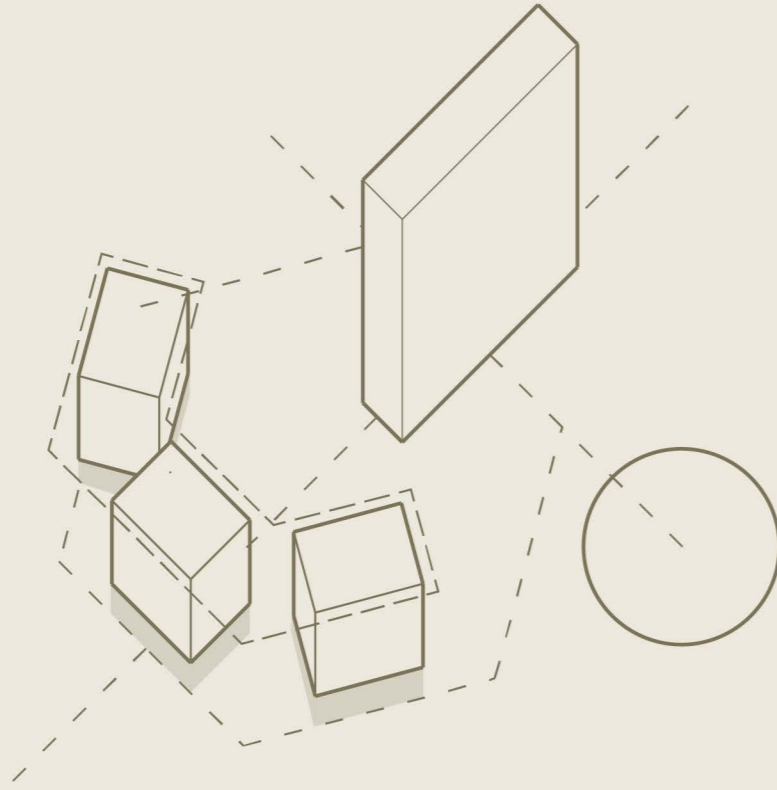

## Approach to the Memorial Zone



Several questions resulted in the following conclusions: the explosion marked the history of Beirut and its citizens, which is present in their collective memory as a moment that left a void due to its strong consequences. Besides, it took irreplaceable lives. Therefore, the ruin of the silos acquires a special meaning. Although it is a constant reminder of this disastrous event, it also represents an element that stood up despite its proximity to the explosion.

With this in mind, the ruin becomes an analogy of Beirut. Even though it has a history of violence and destruction, its resilient character is highlighted. For this reason, the name "Resilience" is assigned to the new monument. This will transform it into a symbol of identity and also a tool that helps to change the past narrative gradually. The ruin is understood as an element that has a different temporality than the elements that surround it. It has lost its original function and is perceived through the fragment, while being reconstructed in the collective mind. In that way, to preserve the ruin and to make a subtle external intervention is decided as this does not allow it to stand in the past, projecting itself towards the future.



← Past Present Future →

## Port area

1. Container zone
2. Empty container zone
3. Free zone
4. Fuel reserve
5. Customs control
6. Food storage
7. Material management
8. Ship repair shed
9. Administration
10. Weighing machine
11. Imported cars
12. Silo building
13. Sheds
14. Control zone



*Isometric view of the Leisure Zone*

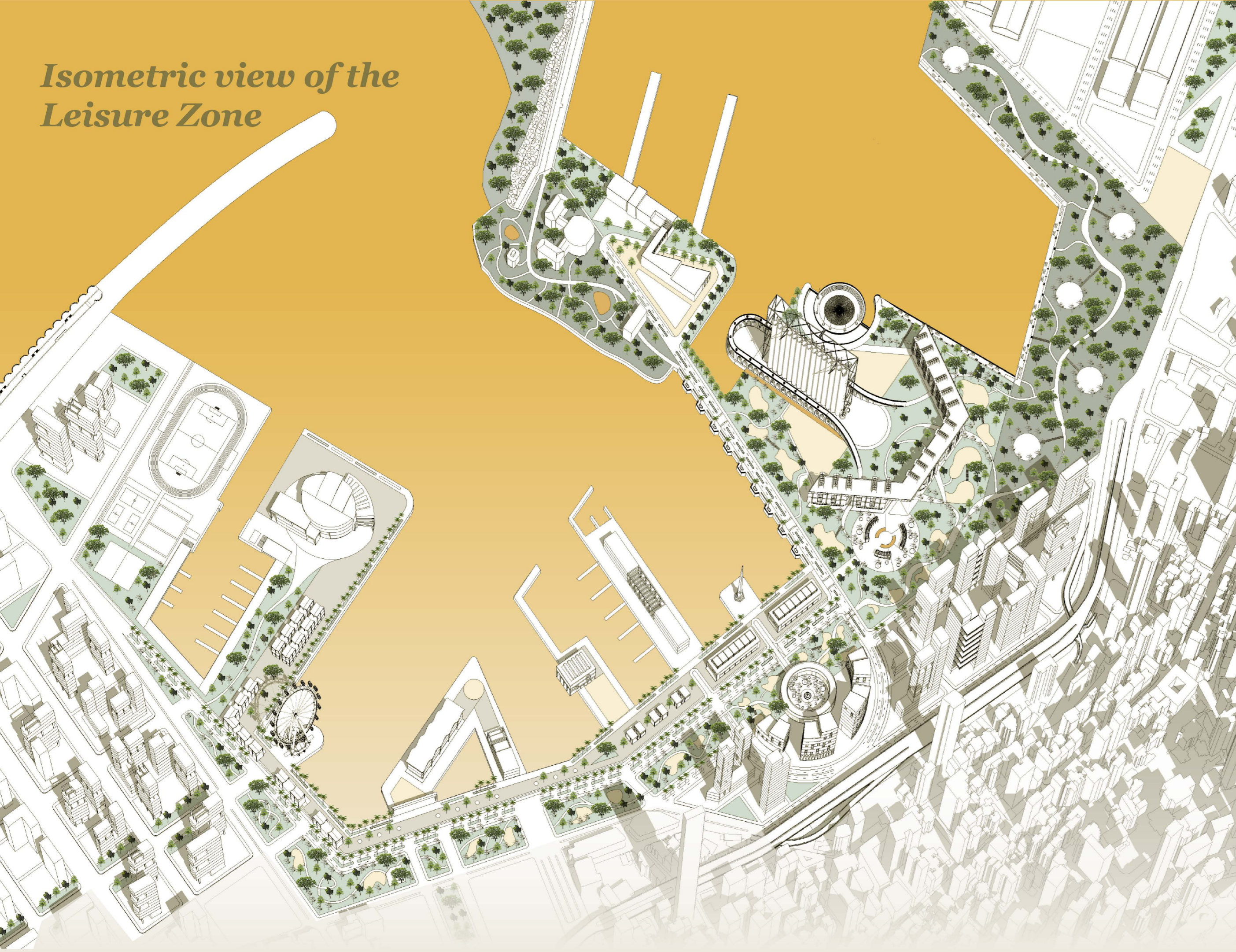

*Tourist's arrival*

1



*Walk around the memorial*

2



*"Living street" section and memorial zone*

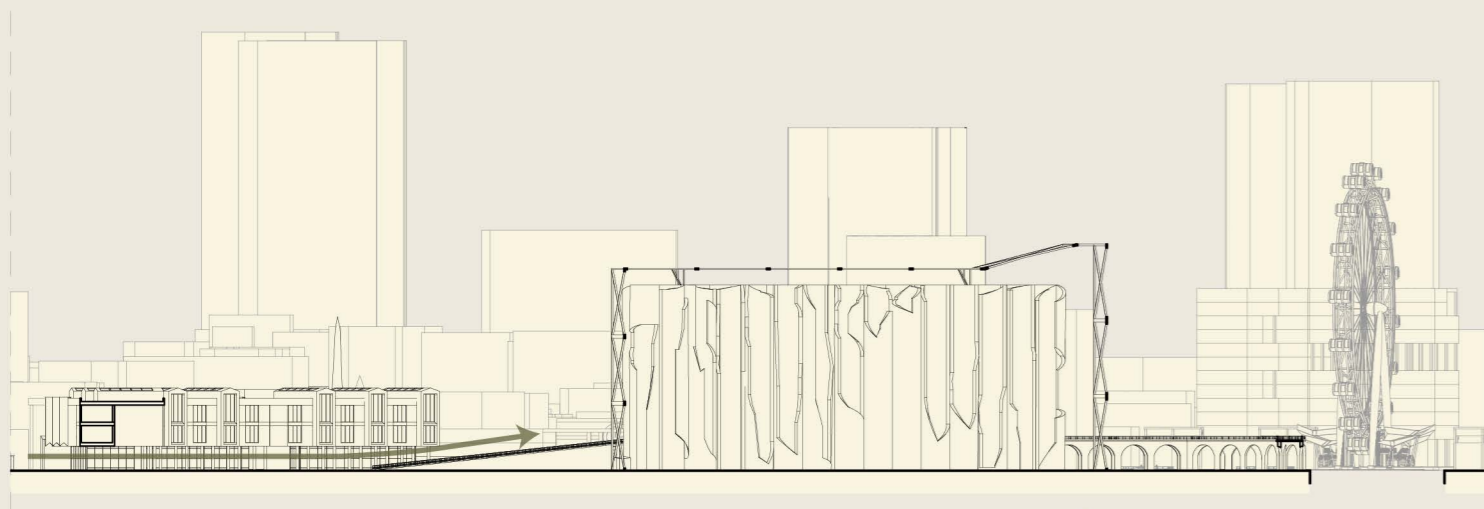

*Sequential approach to the proposal*



**Conclusion**

Beirut is the result of different temporalities which lead to the need to propose a new phase focused on the present and nowadays interests: ecology, economy and society.

The proposal for the new port area focuses on generating spaces that can be used by the citizens, which will allow a better interaction between users, the city, nature and the sea. The proposal focuses on sustainability and the creation of green spaces that are scarce in the area.

Beirut's port proposal as a new temporality is seen as an opportunity to improve efficiency, transport and aim for sustainability, while recognizing its history and looking towards the future.

*Dance show in the amphitheater*

3



*"Living street"*



4

*Walk around the city: approaching the memorial*

5



*Walk around the leisure space*

6

