

SECTION A- A SCALE 1:100

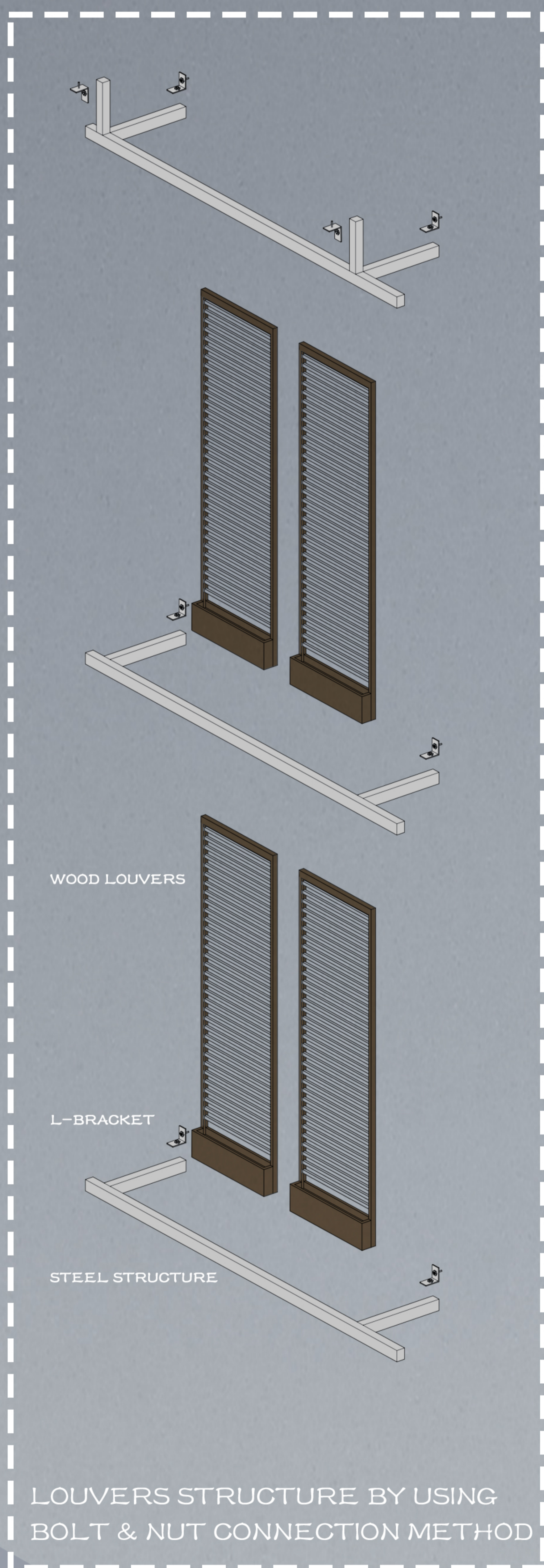

SECTION B- B SCALE 1:100



LOUVERS STRUCTURE BY USING BOLT & NUT CONNECTION METHOD

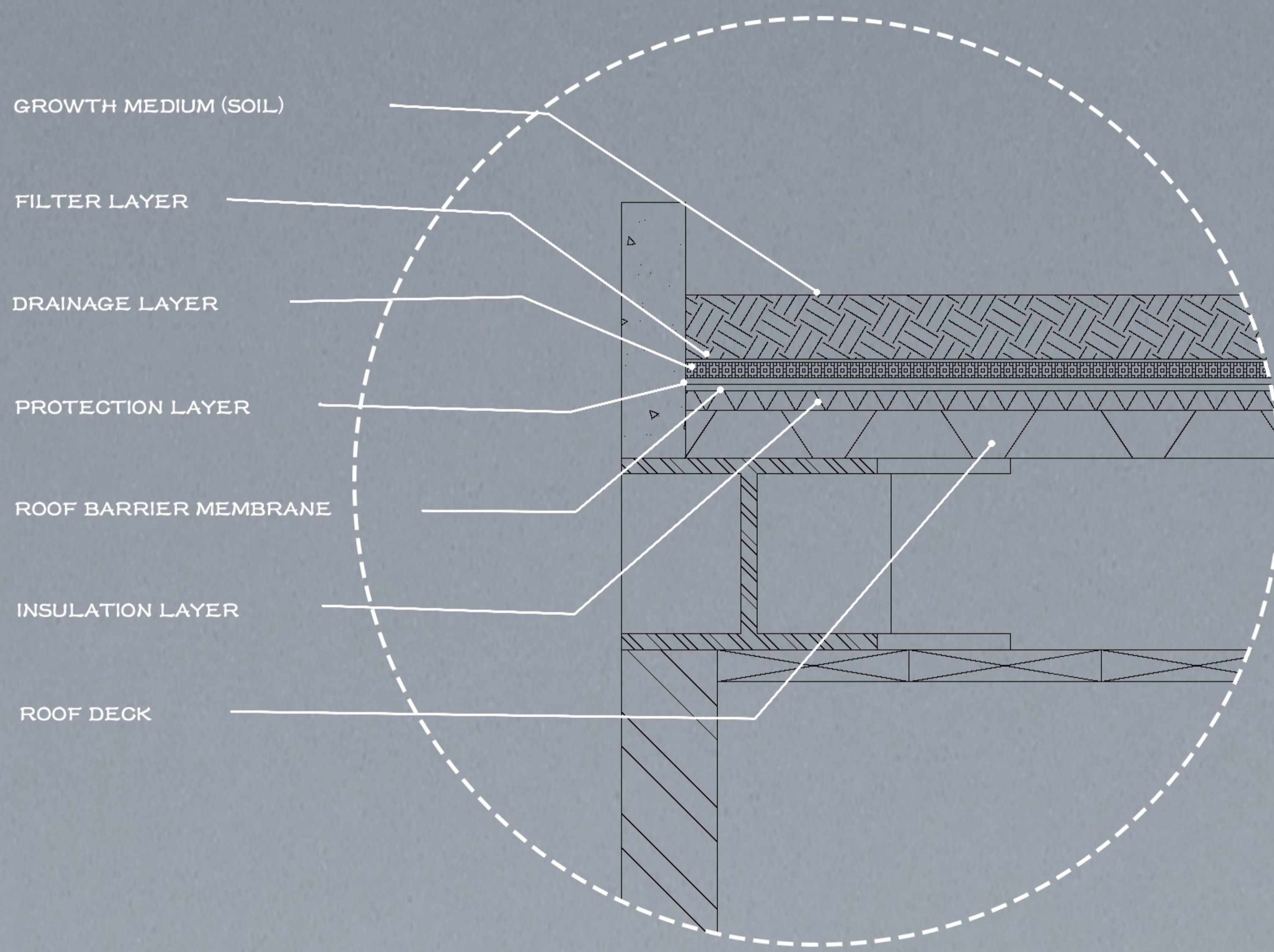

DETAIL SECTION 1 SCALE 1:5

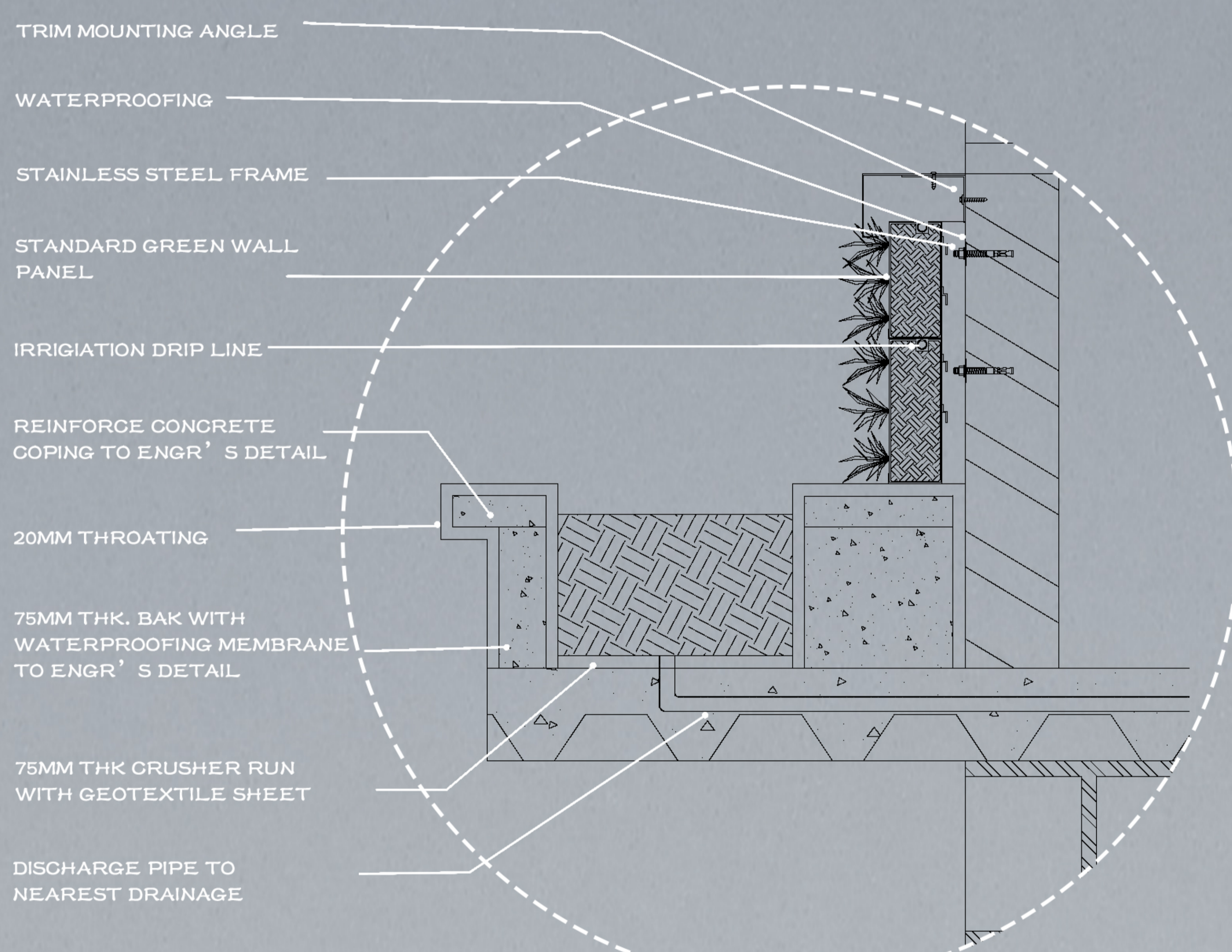

DETAIL SECTION 2 SCALE 1:5

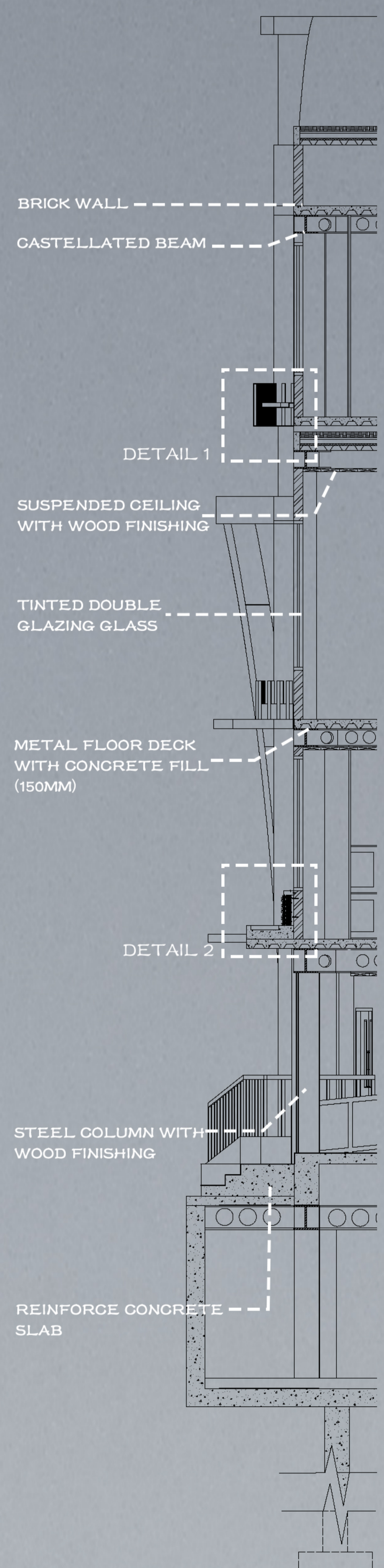

TYPICAL SECTION SCALE 1:40

GBI- SM4
24 Hour access of public ground floor area and Hipster town at the back alley of building.

GBI- EE3
Separate air conditioned zoning for areas with different function and equip with dedicate control

DAYLIGHTING
Glass material and void at the roof to provide the daylighting inside the building.

EXTERNAL VIEW
Long distance view in front of the building and visual connection to reduce the eyestrain for occupant.

MINIMUM INDOOR AIR QUALITY PERFORMANCE
Cross ventilation occurs to allow healthy air flow through the building. This ensure the comfort and well being of building occupant.

GREEN SPACE
External space of building is covered by green space. It is not only for the environment friendly, but also as an urban landscape for community area.

