

Composition

Lack of community participation and social inclusiveness is one of the biggest missing elements in conventional museums. This museum is composed of different spatial elements that enable people to have a collective experience in a street level.

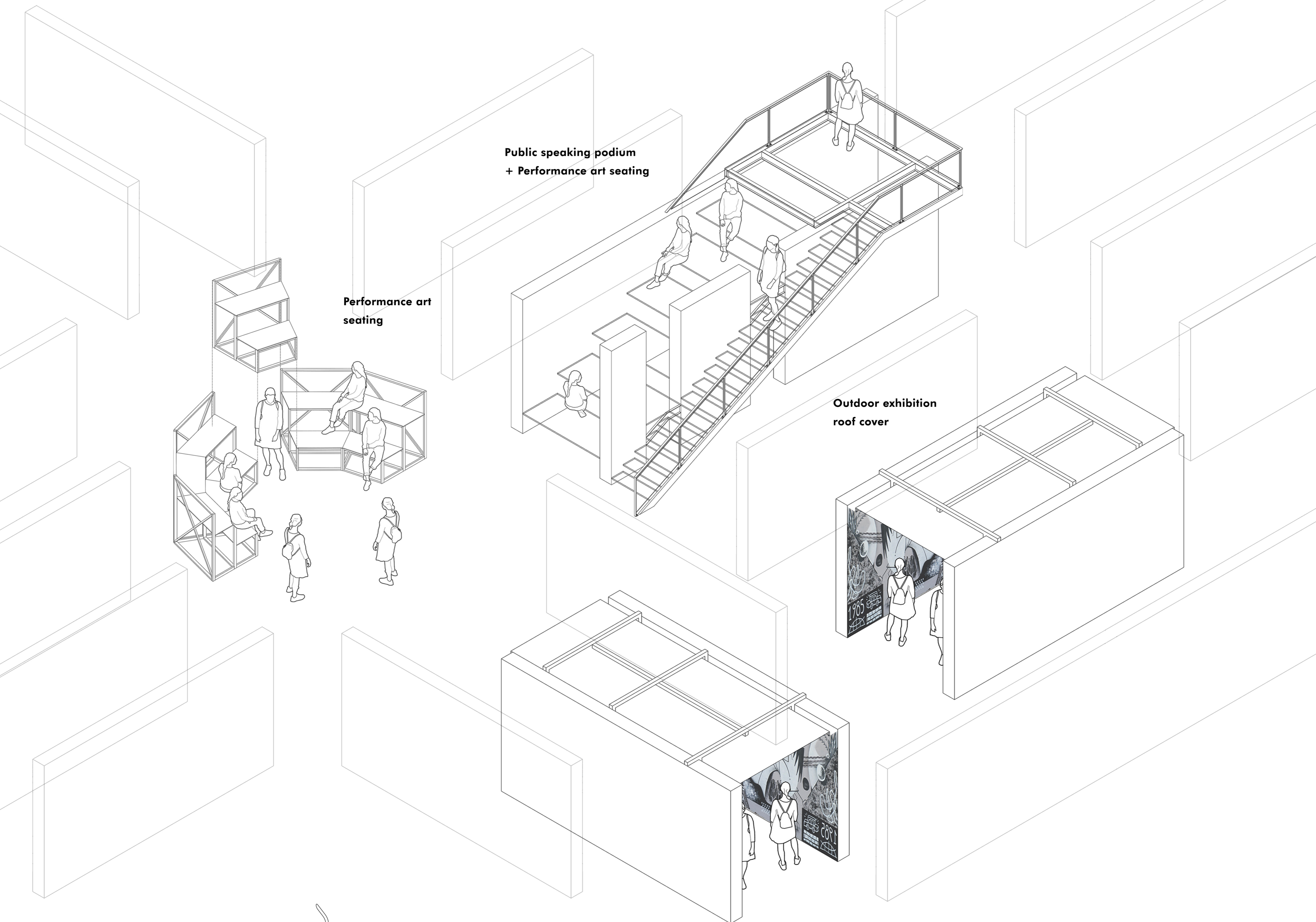

ANALOGY - 01

Analogy I - Tower on wheels

Relating to the everchanging surroundings of a city is complicated by the fact that Nugegoda city has a faster rate of growth and development. Towers by its very nature are detached from its surrounding and street level. Towers on wheels is a straddle carrier integrated with architectural plug ins and has absolutely zero attachments with the site whatsoever. In search of references for towers in Nugegoda first tower that comes to our mind is the simple utilitarian tower at the Nugegoda open air theater. A simple design with the sole purpose of elevating a function physically in order to create a sense of presence around the site and notify the surrounding. Similarly, tower on wheels sets a presence around the site and elevates it's functions to a higher level where everyone can see the events while adapting to the everchanging surroundings of the Nugegoda city.

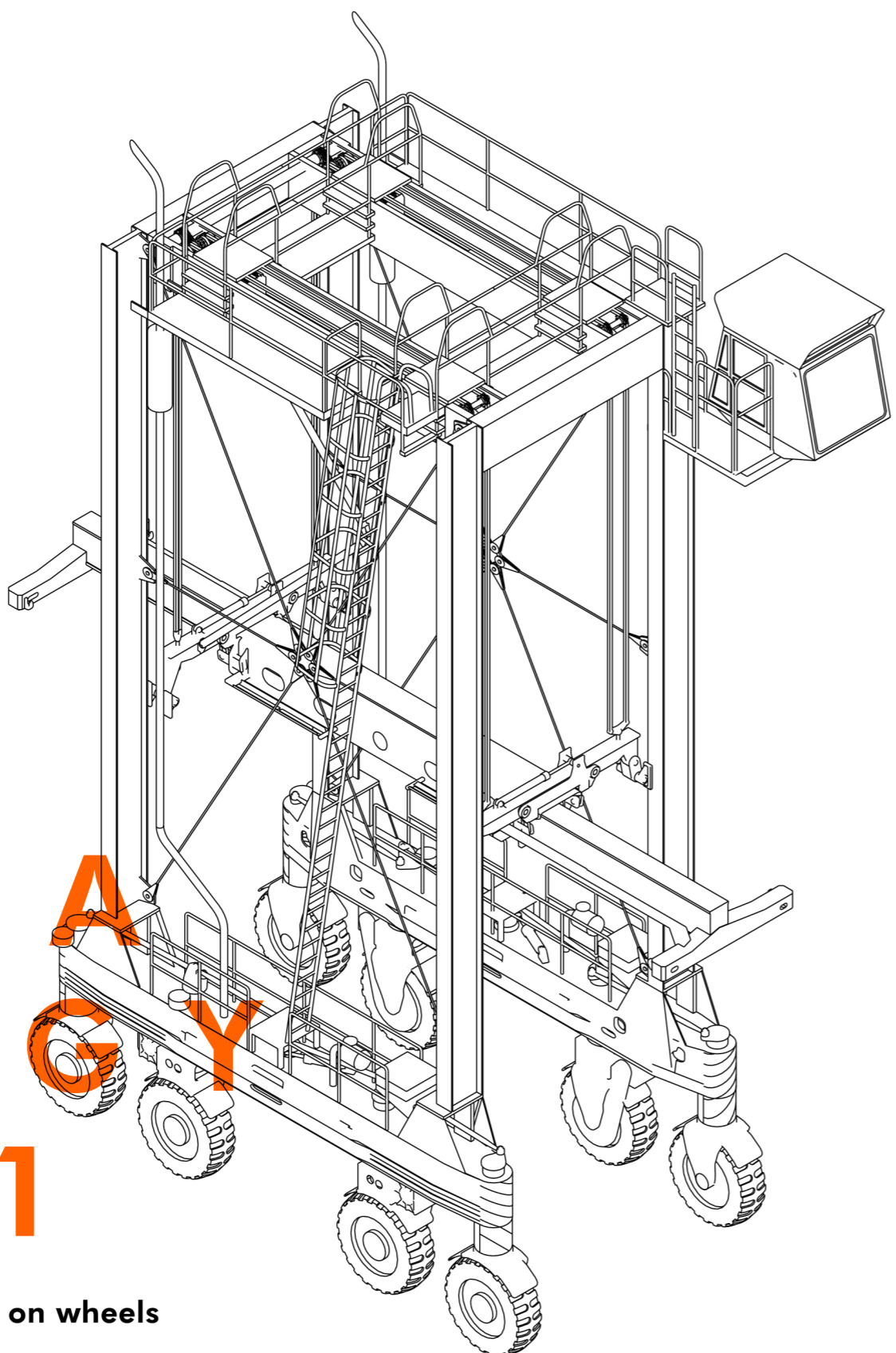

ANALOGY - 02

Analogy II - Freedom of Expression

The open-air theater at the site was accountable for a major number of political meetings that allowed people to use their freedom of expression. Now, the theater not being there anymore can't diminish the political value it had. The museum still provides a democratic participative environment and an experience. The museum also acts as an advocate for political morals as it let anyone use their freedom of expression in a form of art while accommodating conventional meetings. The concrete fins act as canvases allowing people to freely express themselves. Within time the walls will evolve and absorb the colors of the city and will become a part of it. In this case the visitors themselves activate the museum and will take ownership of the museum. Periodically best content will be selected and exhibited on the walls themselves while preserving it using a temporary structure.

