

# OWAH GINGSIR

WHAT IF THE RESILIENCE OF COMMUNITY'S PUBLIC SPACE CAN BE ACHIEVED BY ONLY ENHANCING THE MODEST COMPONENT OF ITSELF?

Owah Gingsir (from *Javanese* Language, means wheel of life) is an interpretation of basic picture living inside Semarang City's one of the most populated settlement. While the government is enhancing vast infrastructure inside the city, people who living under line of prosperous must survive for themselves. Spinning their own wheel in order to keep their existence and leave a tough legacy for the next generation.

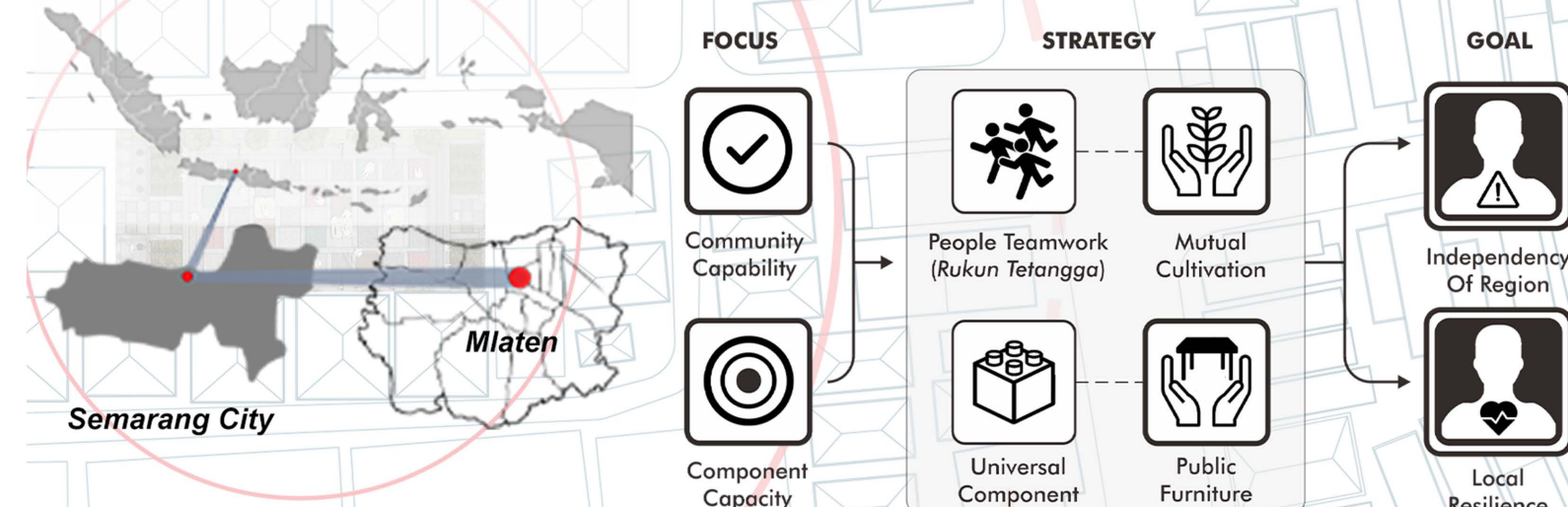

## OVERVIEW

Mlaten is one of the most populated sub-districts in the middle of Semarang City. Since many decades Mlaten was designed for low-income community, and years later it grew into an un-standardized man made space. The ratio of leisure space already knocked by a demand of living, also the proper living quality is decreasing extremely. Each parcel inside contains a specific group of people that called RT (*Rukun Tetangga*) and led by a responsible leader.

In the way of providing a mutual public space, the strategy basically is from securing reachable perimeter to determine who is commonly use the space. Then because each RT has solid teamwork, they are directed to create their own public space's features by using universal standardized component. So then, they can fulfil their own need and ready to keep resilience independently without intervention from major authority.

## WORKPLAN

Universal component is briefly for reviving the crafting culture that almost forgotten also increasing possibility to be innovative in managing furniture need sustain. Mainly, it provides clasping system for any existing material.

Alternatively, some examples were prepared in case of giving simple and useful feature for support their public space.



**SAMBUNGAN** is the universal component itself. Standardized and assembled from 2 parallelogram metals, possible for clasping system. Each component provides holes for the bolted locking of the order's feature.

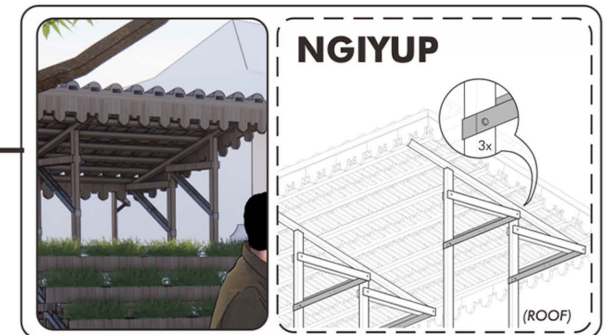
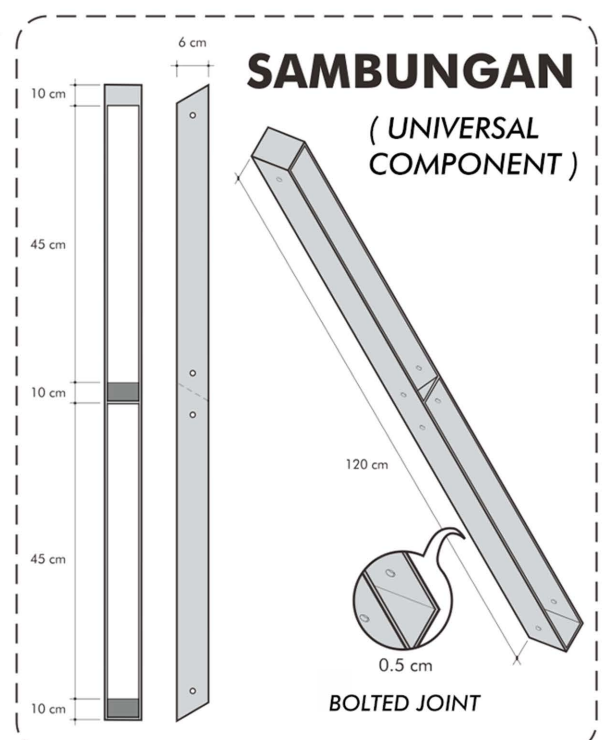

**NGIYUP** is the modest development of the component. By only using its shape, it can support a simple roofing structure for shading of the community's place.

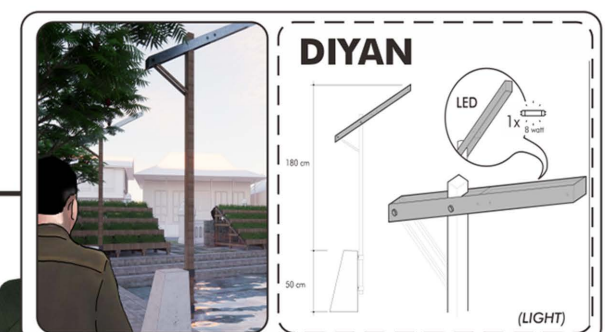

**DIYAN** is another creative development that can provide lumination, especially for dusk or night activities of the area.

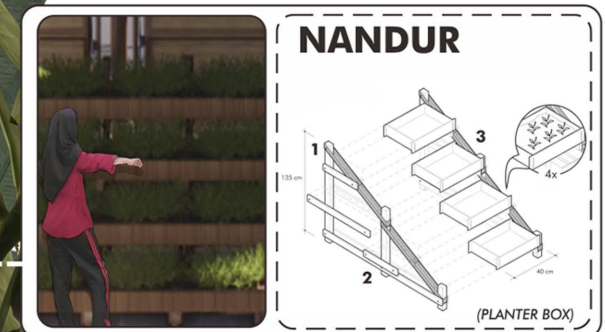

**NANDUR** is no other development that specifically provides a mutual space for plant cultivation. **NANDUR** can be really low and humble but also can be tall and brave based from the community's demand and available space.

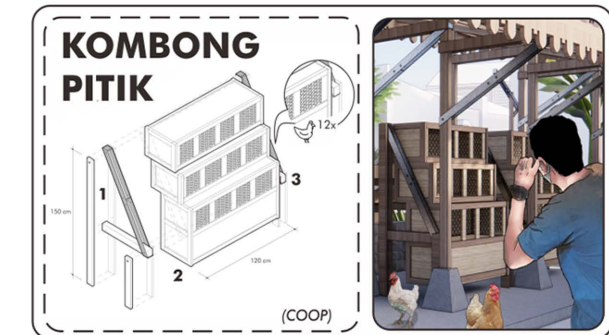

**KOMBONG PITIK** is a specific development, that can provide as a coop for consumption and breed of poultry. **KOMBONG PITIK** can be as simple and small but also as big and large based the community's demand.

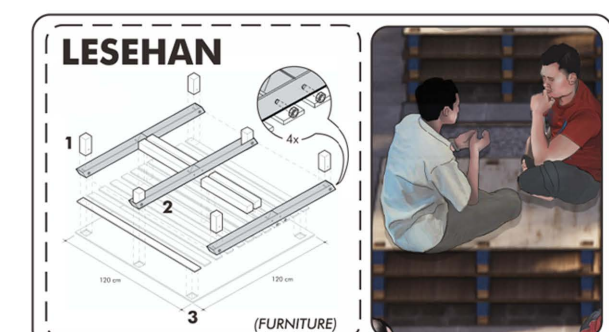

**LESEHAN** is the most iconic development. Helpful for providing sitting area and the surface to put stuff which has to take care of. Stacking is possible for adjusting the height.



**PADASAN** is an alternative development, that answer sanitair urgency of the area. It might be possible to corelate with small or medium water tank in the way of keeping water need safely.

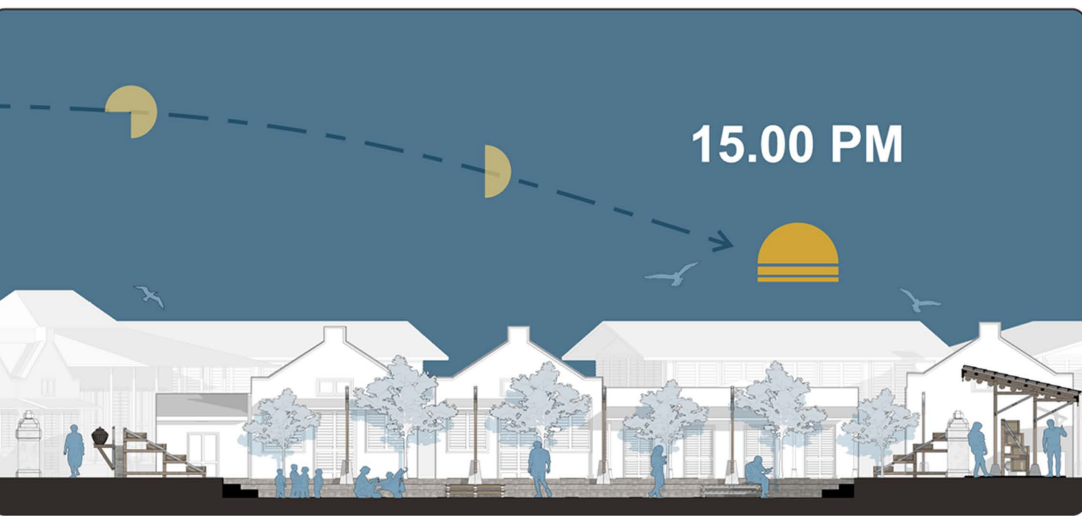
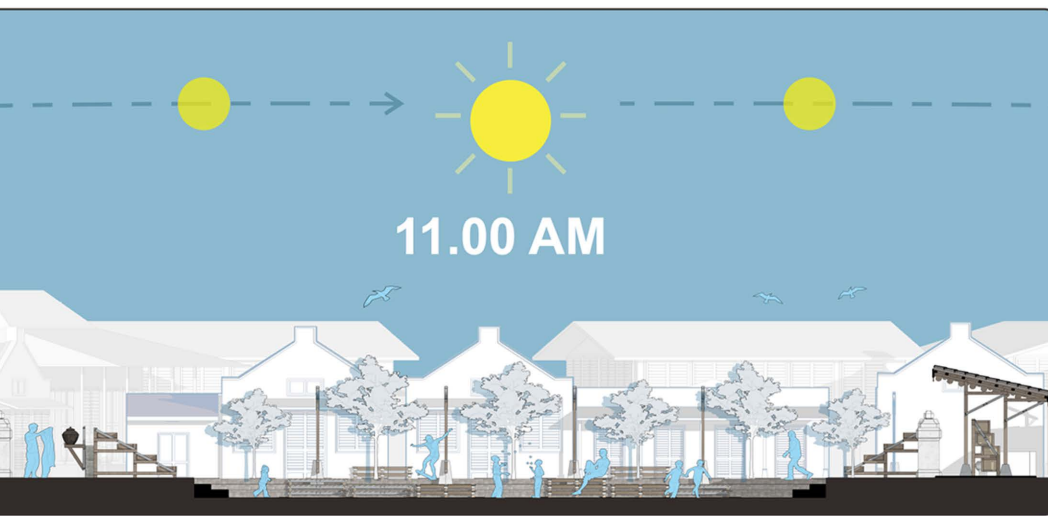
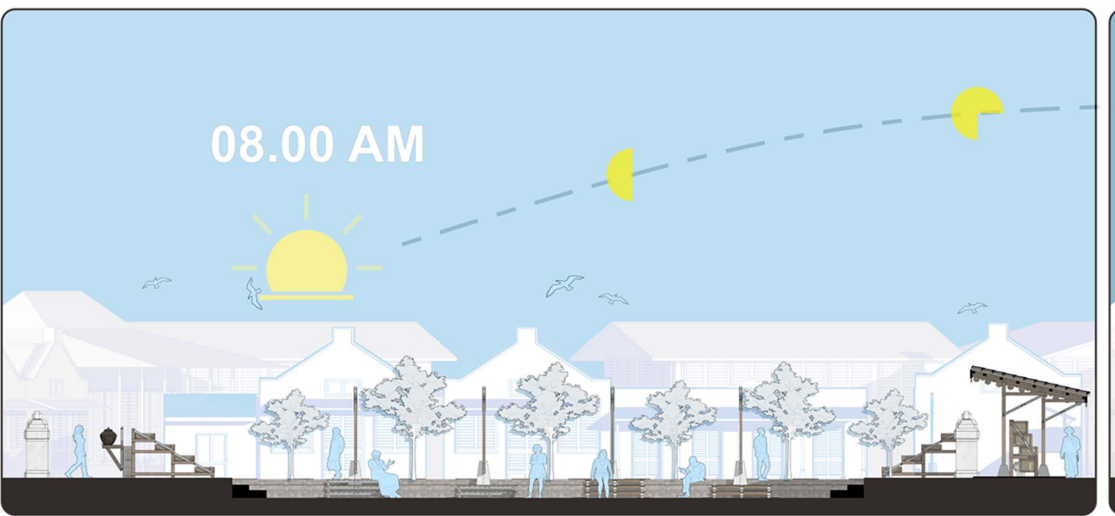
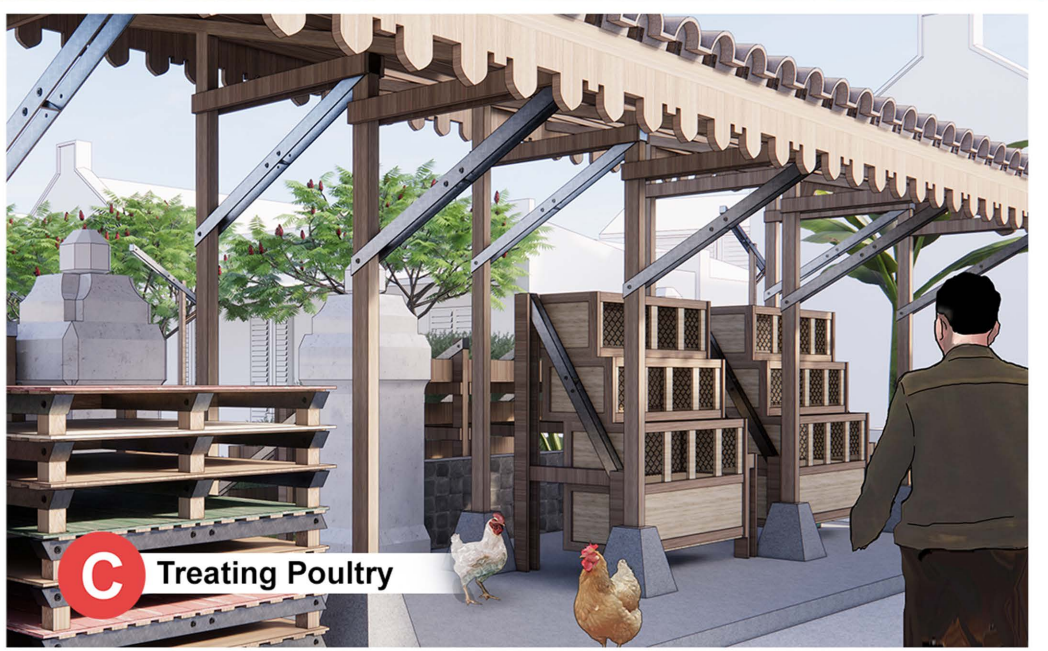
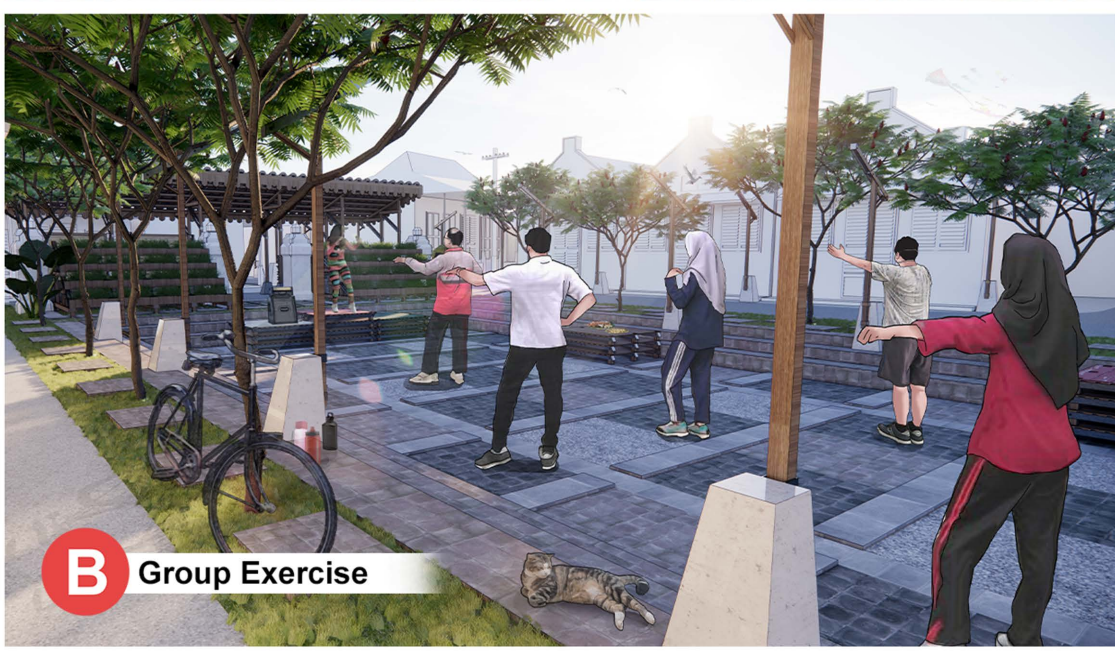
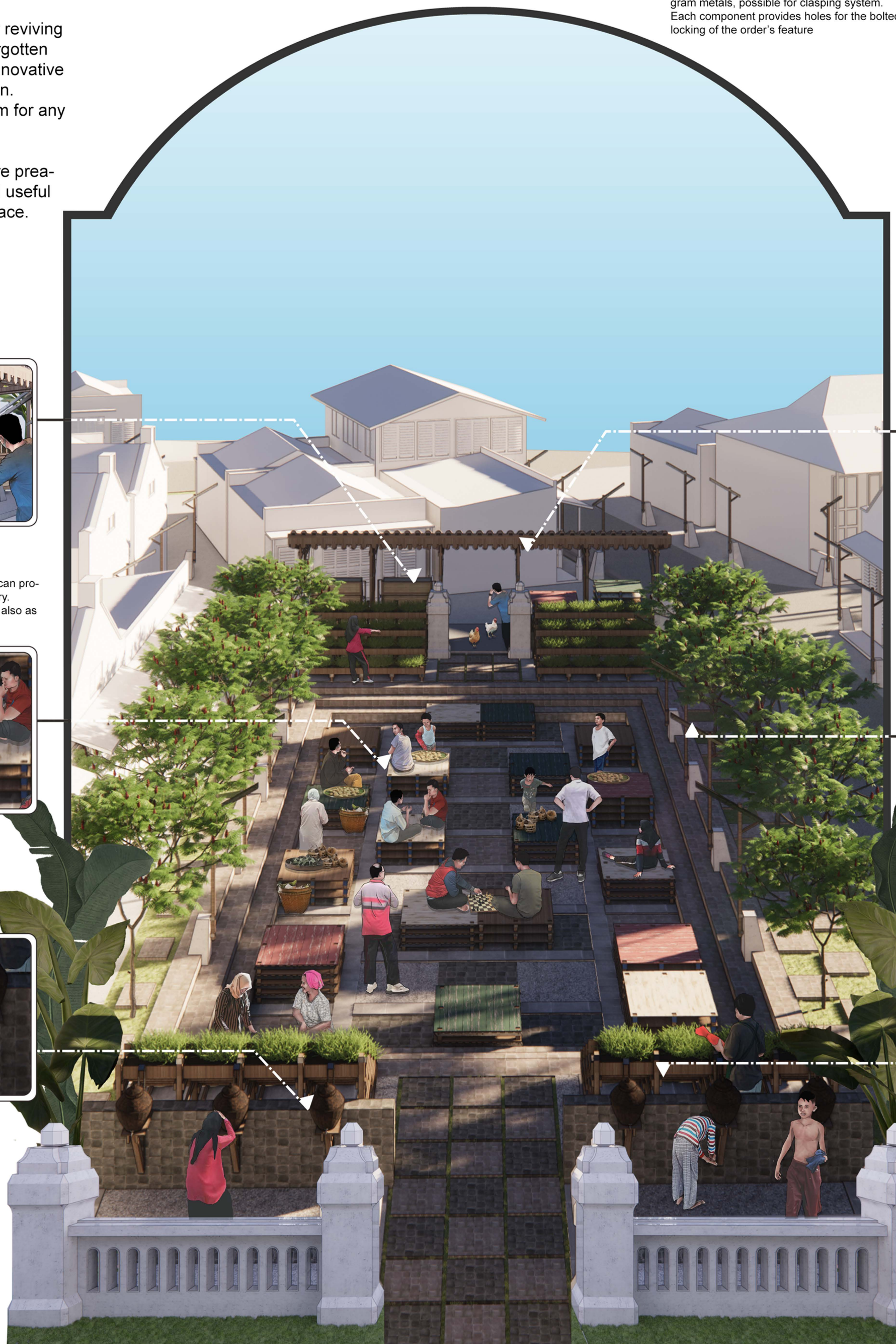

Timeline Activity: Morning (E, B, A), Day (C, F), Afternoon - Night (E, F, G, D)

**Morning**  
When sun raises up, women from community start doing daily Morning Market, also they create communal exercise in the weekend. Other local members start treat cultivation plant or poultry. Shared field concept based time is empowered for balance inside the community.

**Day**  
When the morning density ends, children are encouraged to play around and use the shared field for their leisure. For some adults, they may simply clean clothes aside or take care of poultry back inside the coop.

**Afternoon - Night**  
Sun sets, the children and adults make their own way to fulfil shared field. Especially in the night of the weekend, some other prepare a public cinema to give an extra amusement. But in case of rainy season, shared field directed to be a pond to reduce annual flood problem. It also provides fish cultivation.

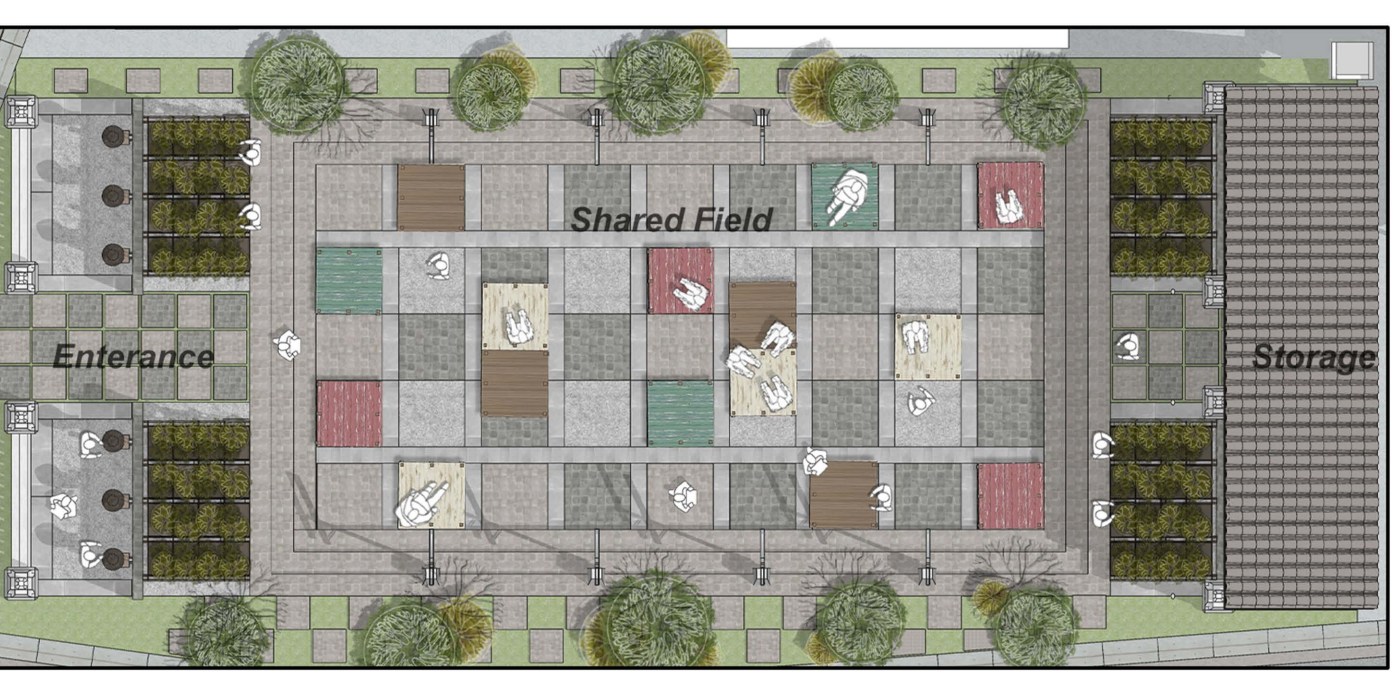

## PLAN

Main area inside the public space basically contains roomy surface with grid order as a respond of distancing limit. Main area inside the public space basically contains roomy surface with grid order as a respond of distancing limit. Main entrance is provided with sanitary feature which fulfil health protocol and encourage it to turn into a community's habit. Behind area is provided for storage area, cultivation also poultry features, which support basic needs (food) for the community.



## SECTION

The terrace surface around the main area gives a depth of level for collecting excess water form rainy season that usually causing a flood inside the settlement. The pond scenario also encourages community to do fish cultivation and complete the resiliency for the next journey.