

INTRODUCTION

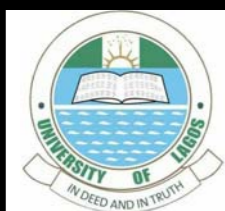

A hotel is an establishment that provides paid lodging on a short-term basis. Facilities provided may range from a modest-quality mattress in a small room to large suites with bigger, higher-quality beds, a dresser, a refrigerator and other kitchen facilities, upholstered chairs, a flat screen television and en-suite bathrooms.



PROJECT DEFINITION

According to collins dictionary, a 5-star hotel is a top-quality hotel offering exceptional luxury through all its means of operation.

A 5-star hotel is geared towards catering to the guests at the highest level. Therefore, everything from the exterior of the hotel down to the tableware should display excellent quality and high attention to detail.

In order to achieve this accreditation, your hotel is required to complete a selfassessment form. All hotels can conduct a trial assessment without charge to see if they make the grade required. We supply the assessment document and also the guide which identifies the minimum mandatory requirements before we confirm the outcome.

PROJECT JUSTIFICATION

hospitality is so important in life. providing an environment that is comfortable and enjoyable is much more important than feeling pressure to have a perfect home.

The primary purpose of a hotel is to provide travellers with shelter, food, refreshment and similar services and goods, offering on a commercial basis things that are customarily furnished within households but unavailable to people on a journey away from home.

**DESIGN BRIEF**

the project is to design a 5star, high rise hotel in the heart of lagos (lagos island, marina) with the green guild five star rating system. the hotel is to be designed with distinctive quality that will capture and enhance the urbanizing momentum of Lagos island, offering the highest standards of luxury with impeccable service delivery. The proposal would be a minimum of 36 floors and will respond effectively to the needs of all and sundry.

DESIGN CONSIDERATIONS

- sustainability
- functionality
- luxury and comfort
- ease of access
- sense of place
- aesthetics
- human interaction
- smart building integration

AIM

the aim of the project is to design a hospitality building that provides a welcoming environment and supports the comfort of its guests for work, rest and relaxation through appreciation of the physical environment.

OBJECTIVES

to develop a contemporary design that's environmentally friendly and blends with its immediate environment.

HISTORY OF HOTELS

The history of hotels is intimately connected to that of civilisations. The precursor to the modern hotel was the inn of medieval Europe. Facilities offering guests hospitality have been in evidence since early times. The Greeks developed thermal baths in villages designed for rest and recuperation. Later, the Romans built mansions to provide accommodation for travellers on government business. The Romans were the first to develop thermal baths in England, Switzerland and the Middle East. Later still, caravanserais appeared, providing a resting place for caravans along Middle Eastern routes. In the Middle Ages, monasteries and abbeys were the first establishments to offer refuge to travellers on a regular basis. Religious orders built inns, hospices and hospitals to cater for those on the move. For a period of about 200 years from the mid-17th century, coaching inns served as a place for lodging for coach travellers (in other words, a roadhouse). Coaching inns stabled teams of horses for stagecoaches and mail coaches and replaced tired teams with fresh teams. The start of the hotel industry - At the beginning of the fifteenth century, more than 600 inns were registered in England. Their architecture often consisted of a paved interior court with access through an arched porch. The bedrooms were situated on the two sides of the courtyard, the kitchen and the public rooms at the front, and the stables and storehouses at the back. The first guide books for travellers were published in France during this period. An embryonic hotel industry began to develop in Europe. Distinctive signs were hung outside establishments renowned for their refined cuisine. At the end of the 1600s, the first stage coaches following a regular timetable started operating in England. Half a century later, clubs similar to English gentlemen's clubs and masonic lodges began to appear in America.

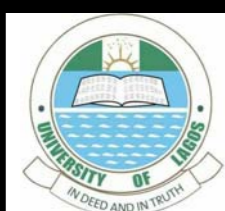

TYPES OF HOTELS



LIFESTYLE LUXURY RESORTS

Lifestyle luxury resorts are branded hotels that appeal to a guest with lifestyle or personal image in specific locations.

UPSCALE FULL-SERVICE

Upscale full service hotels often provide a wide array of guest services and on-site facilities.

BOUTIQUE

Boutique hotels are smaller independent non-branded hotels that often contain mid-scale to upscale facilities of varying size in unique or intimate settings with full service accommodations.

FOCUSED OR SELECT SERVICE

Small to medium-sized hotel establishments that offer a limited number of on-site amenities that only cater and market to a specific demographic of travellers, such as the single business traveller.

ECONOMY AND LIMITED SERVICE

Small to medium-sized hotel establishments that offer a very limited number of on-site amenities and often only offer basic accommodations with little to no services.

EXTENDED STAY

Extended stay hotels are small to medium sized hotels that offer longer term full service accommodations.

TIMESHARE AND DESTINATION CLUBS

Timeshare and Destination clubs are a form of property ownership also referred to as a vacation ownership involving the purchase and ownership of an individual unit of accommodation for seasonal usage during a specified period of time.

MOTEL

A motel, an abbreviation for "motor hotel", is a small-sized low-rise lodging establishment similar to a limited service, lower-cost hotel, but typically with direct access to individual rooms from the car park.

MICROSTAY

Hotels may offer rooms for micro stays, a type of booking for less than 24 hours where the customer chooses the check in time and the length of the stay.

CLASSIFICATION OF HOTELS

Hotel classification systems are widely used in the accommodation sector as a means of providing an indicator to both consumers and intermediaries on the standards to be found at individual establishments.

Hotel classification is the ranking of hotels, usually by using nomenclature such as stars (or diamonds), with one star denoting basic facilities and standards of comfort and five stars denoting luxury in facilities and services.

The purpose is to inform intending guests in advance on what can be expected in order to reduce the gap between expected and experienced facilities and service delivery. The terms 'grading', 'rating', 'classification' and 'star rating' are used to refer to the same concept, i.e. to rank hotels by their facilities and standards.

<p style="text-align: center;">★</p> <p>At least 5 bedrooms with en-suite</p> <p>Open 7 days a week</p> <p>Guests have access at all times</p> <p>Clearly defined reception area</p> <p>Restaurant serving breakfast \ 7 days a week & evening meals 5 days a week</p> <p>Licensed bar</p>	<p style="text-align: center;">★★★</p> <p>all from 2stars plus...</p> <p>Access without a key</p> <p>Dinner Served 6 evenings a week, snacks on the 7th</p> <p>Room service for drinks & snacks during daytime and evening</p> <p>All bedrooms en-suite</p>	<p style="text-align: center;">★★★★★</p> <p>all from 4stars plus...</p> <p>Open all year round</p> <p>Proactive service & customer care</p> <p>Multilingual receptionists</p> <p>Additional facilities such as a multiple restaurant areas, business centre, spa & permanent luxury suite</p> <p>Enhanced services such as a valet parking, concierge & escort to bedroom</p> <p>Restaurant open every day for all meals</p>
<p style="text-align: center;">★★</p> <p>all of the above plus...</p> <p>Higher standards of cleanliness, hospitality & maintenance</p>	<p style="text-align: center;">★★★★</p> <p>all from 3stars plus...</p> <p>24-hour room service</p> <p>Restaurant open to residents & non-residents every day</p> <p>Higher staffing levels</p> <p>24-hour access facilitate by on-duty staff</p> <p>En-suite bathrooms</p> <p>Enhanced services</p>	

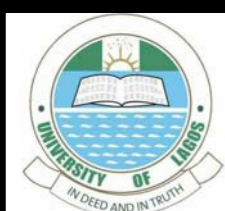

LOCATION MAP

SUBJECT SITE

AFRICAN MAP SHOWING WEST AFRICAN REGION

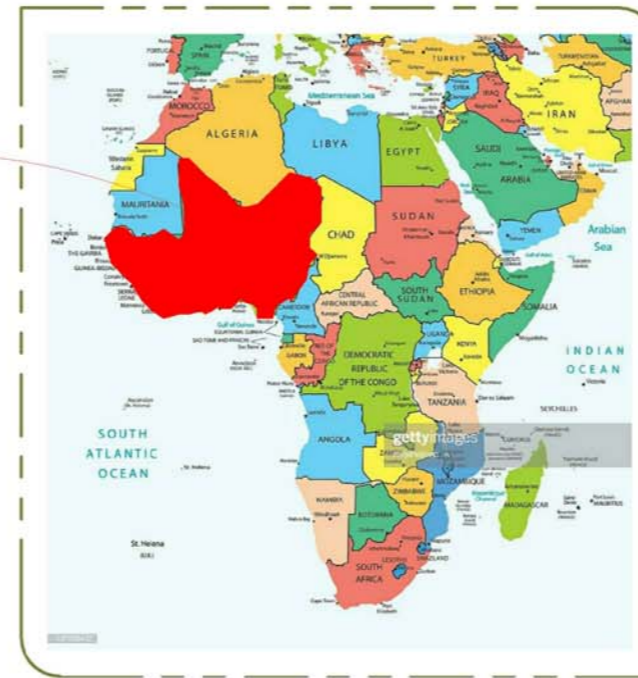

WEST AFRICAN MAP SHOWING NIGERIA

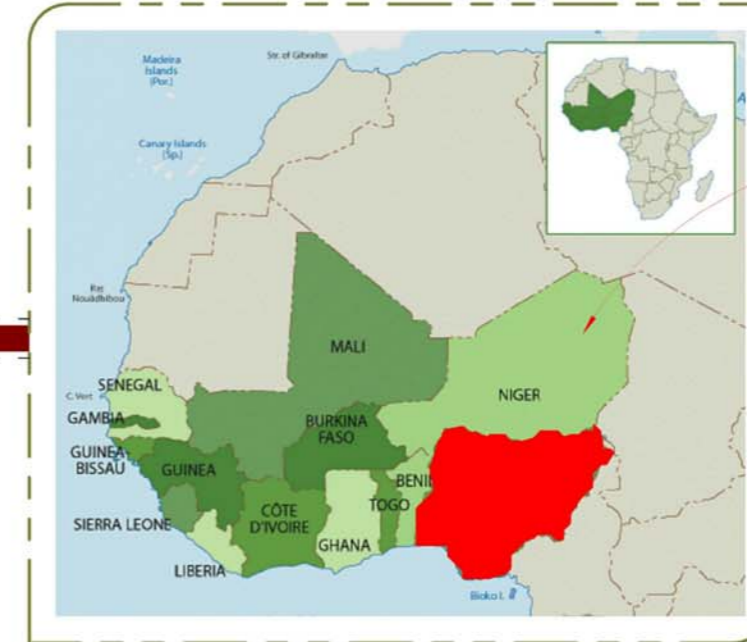

NIGERIAN MAP SHOWING LAGOS STATE



MARINA MAP SHOWING THE PROJECT SITE

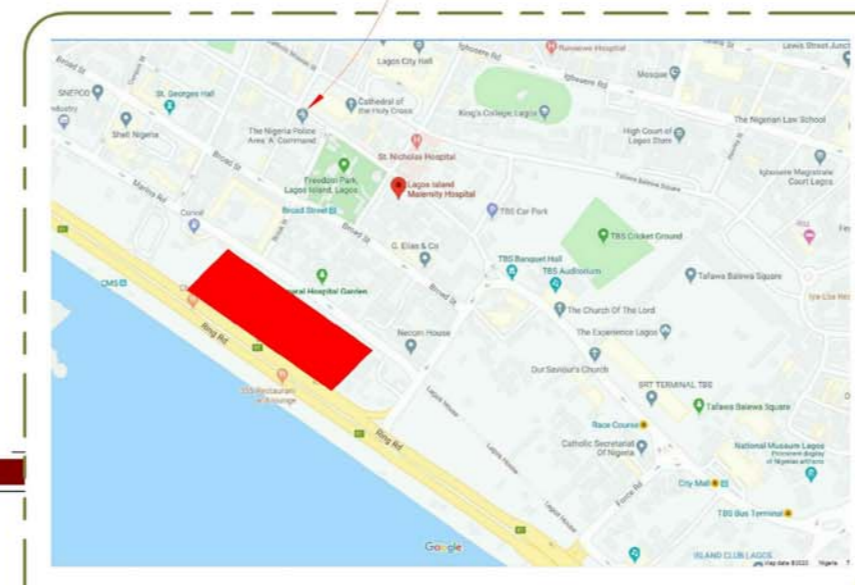

LAGOS STATE MAP SHOWING LAGOS ISLAND LGA



FINAL PROJECT SITE

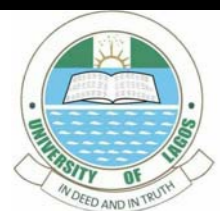

SITE ANALYSIS

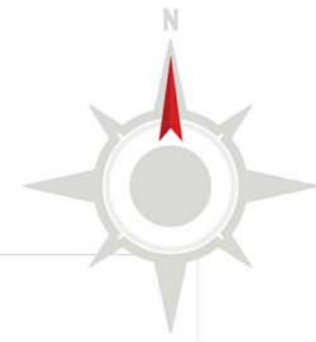

CONOIL



FEDERAL MINISTRY OF JUSTICE



GENERAL HOSPITAL GARDEN



NORTH EAST WIND:

THE NORTH EAST, FROM THE SAHARA DESERT, IS DRY, HAZY, HOT, DUSTY, ETC. THIS WIND IS ALSO RESPONSIBLE FOR HARMATAN IN PLACES ACROSS ITS PATHS. BECAUSE OF ITS DUSTY NATURE, DESIGNERS SOMETIMES USE VEGETATION AS BUFFERS AND FILTERS.

SUN SET:

THE SUN STARTS SETTING AT ABOUT 5 PM. THE INTENSITY AND ANGLE OF ITS INCLINATION ARE VERY LOW.

GRADIENT/SLOPE:

THE SITE SLOPE IS RELATIVELY FLAT.

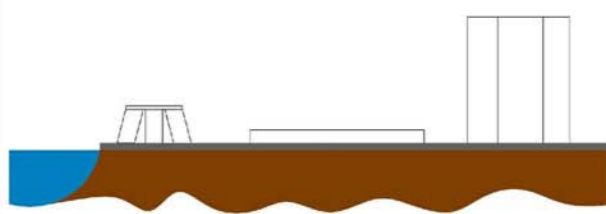

SITE SECTION A - A

SUN RISE:

THE SUN RISES IN THE EAST AT ABOUT 8 AM IN THE MORNING.

NTEL BUILDING



MID-DAY SUN

THIS OCCURS AT 12 NOON AT AN AVERAGE TEMPERATURE OF ABOUT 33°C.

NOISE

NOISE GENERATED FROM VEHICLES, PEDESTRIANS AND ACTIVITIES

NITEL BUILDING



MARINA BRIDGE



SOUTH WEST WIND

SOUTH WEST WIND COMES FROM THE ATLANTIC OCEAN. THE WIND IS MOISTY AS A RESULT OF ITS SOURCE, AND ITS RESPONSIBLE FOR RAIN ACROSS THE HINTERLANDS. THIS IS DESIRABLE WITHIN AN INTERIOR FOR NATURAL COOLING, AND HENCE DESIGNERS MAKE THE MOST OF ITS COOLING EFFECT THROUGH PROPER BUILDING OR STRUCTURE ORIENTATION.



ISLAND POWER PROJECT

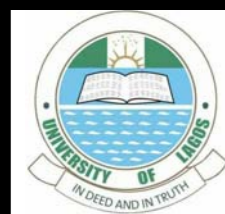

SITE ANALYSIS

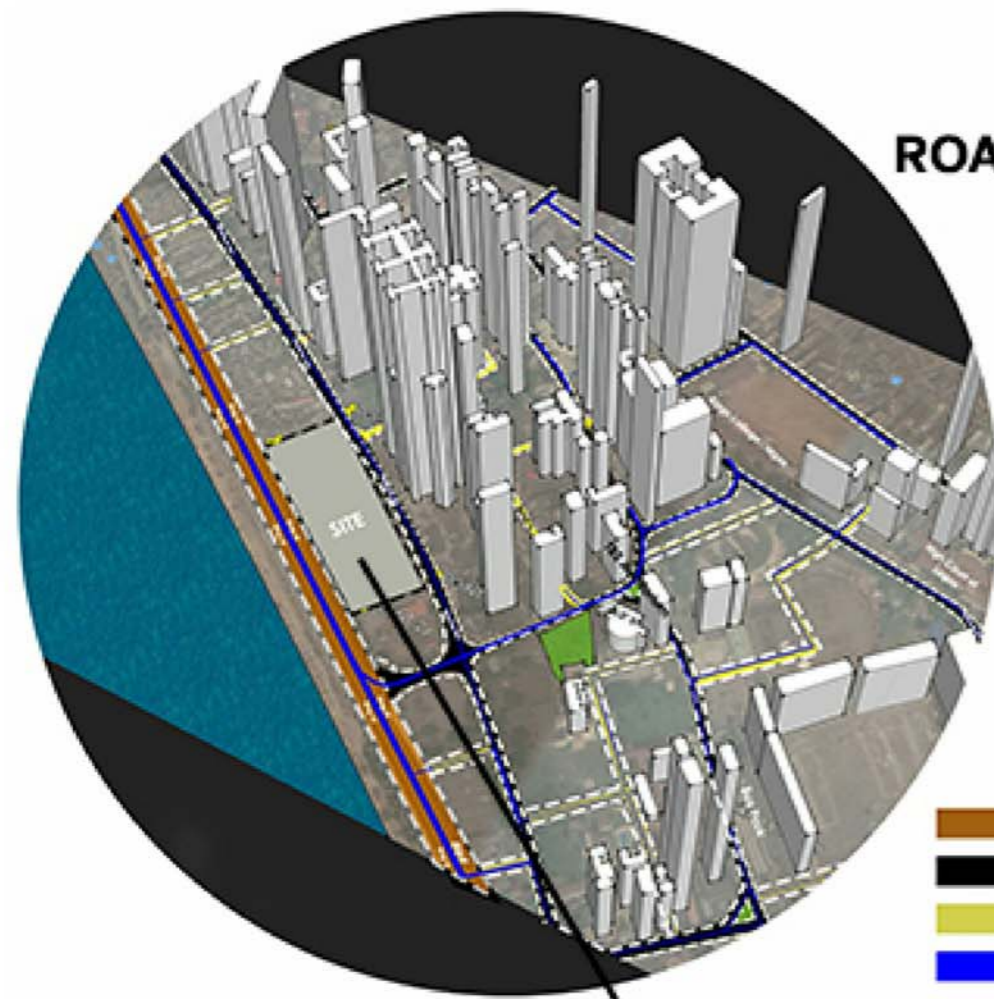

ROAD NETWORK



- Federal Road
- State Roads
- District Roads
- Movement Flow

LAND USE ANALYSIS



- COMMERCIAL
- INSTITUTIONAL
- RESIDENTIAL

LANDMARKS



PROPOSED SITE PICTURE

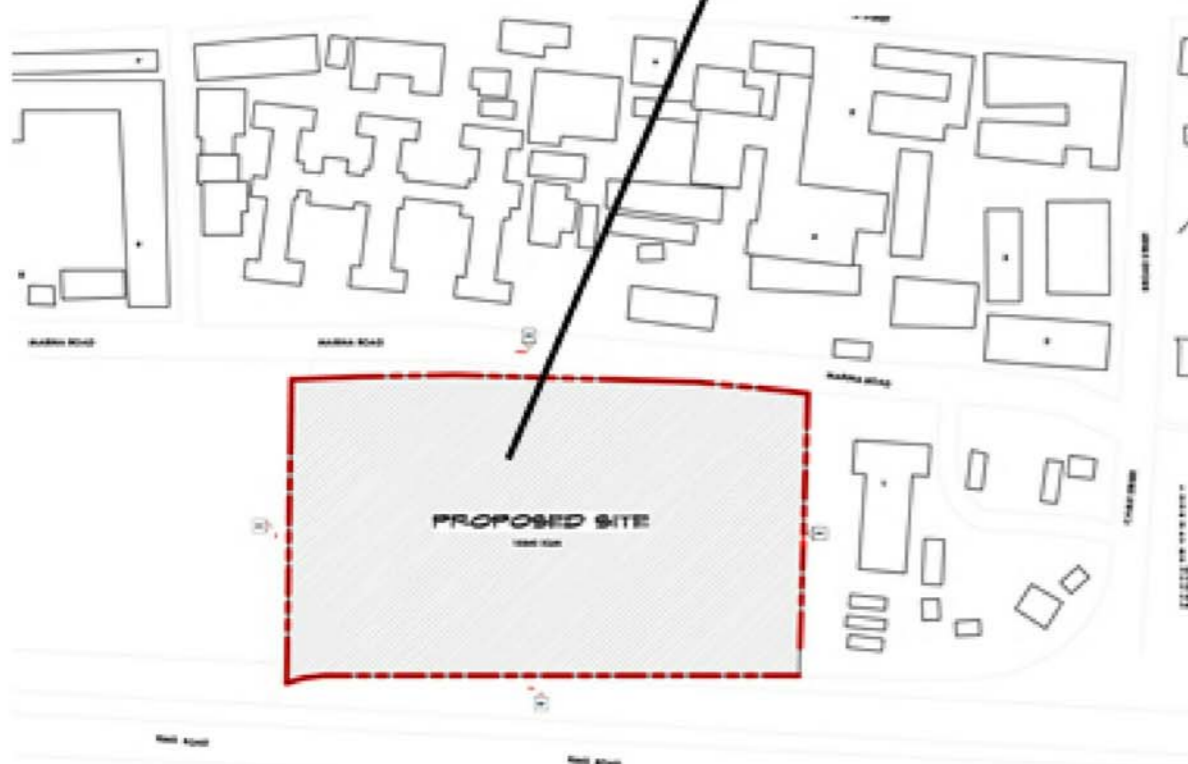

The site is located at Lagos island, having an area of 18,840 sq meters . The traffic level minimal. It has an excellent drainage system. The site is bounded by cable street at the right and brook street by the left. The main entrance into this site is through the Marina road. Major landmarks are State house, Necom house, Island power plant, Accident and Emergency center. Services include fuel and gas station along the access road. The light cables are located underground.

The topography of the site terrain indicated the pattern of the city terrain to be relatively flat, it is also a few meters high above the sea level. The drainage system of the state and the terrain pattern which is relatively flat increases the risk of pluvial flooding: "that is flooding as a result of high intensity of rainfall". Likewise, the state bordering the ocean in the South also increases the risk of tidal flood. Lagos is one of the states in Nigeria that experiences flooding almost every year during raining seasons, hence, the site would require adequate drainage as Lagos Island has a 98% Risk of flooding according to research.

The state experiences Tropical wet and dry climate coded AW according to Koppen's classification. Two air masses, namely Tropical Maritime and Tropical Continental, blowing from the Atlantic Ocean and the Sahara Desert respectively determine the two dominant seasons wet (April-October) and dry (November- March)



view of eko bridge



Federal Ministry of Justice



Our Saviour's Church



Island Power Project



interconnect clearing house



Necom House



general hospital Odan

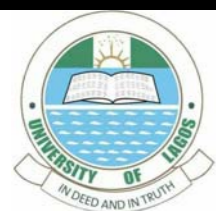

CASE STUDY I

EKO HOTELS & SUITES

LOCATION: LAGOS, NIGERIA
YEAR : 1977
ARCHITECT: OLUWOLE OLUMUYIWA
CLIENT: CHAGOURY GROUP
NUMBER OF ROOMS: 825

FACILITIES PROVIDED: GARAGE BASEMENT, TECHNICAL & SERVICE BASEMENT, LOBBY AREA, BAR, RESTAURANT, CAFE, ETC.

MATERIALS: CONCRETE AND STEEL

EKO HOTEL IS THE MOST PREFERRED HOTEL IN WEST AFRICA. LOCATED IN THE HEART OF VICTORIA ISLAND AND SHIELDED FROM THE HUSTLE AND BUSTLE OF THE LAGOS METROPOLIS, THEY OFFER CLIENTS AND WALK IN GUESTS A PERFECT BLEND OF RELAXATION, ACTIVITIES AND AFRICAN TRADITION DELICATELY INFUSED TO MEET THE HIGHEST INTERNATIONAL STANDARDS.

OVERLOOKING THE EKOATLANTIC CITY AND OCEAN, THE HOTELS ARE DESIGNED FOR YOUR COMFORT AND CONVENIENCE.

THE HOTEL HAS TAKEN IMPORTANT STEPS TO LIVE UP TO WEST AFRICA'S FUTURE MODEL IN THE HOSPITALITY SECTOR. WITH THE BEST CONFERENCE AND BANQUETING FACILITIES, TASTEFULLY FURNISHED TO A 7000 SEATER CAPACITY, A WORLD CLASS SWIMMING POOL, 824 EXCELLENTLY FURNISHED SPREAD ACROSS 4 HOTELS WHICH ARE; EKO SIGNATURE, EKO HOTEL, EKO SUITES AND KURAMO GARDENS. THEY HAVE 9 DIFFERENT RESTAURANTS AND 7 DIFFERENT BARS SERVING A RANGE OF INTERNATIONAL CUISINES, AMONGGST OTHER FACILITIES.

THE HOTEL IS EQUIPPED WITH A STATE OF THE ART HEALTH AND FITNESS CENTRE COMPRISING OF A GYM, A TENNIS/BASKETBALL COURT, A VOLLEYBALL COURT, A SAUNA, SPA, SALON AND NAIL STUDIO. THEY HAVE AN IN-HOUSE MEDICAL CLINIC AS WELL.

EKO HOTEL IS COMMITTED TO EXCEEDING GUESTS' EXPECTATIONS.

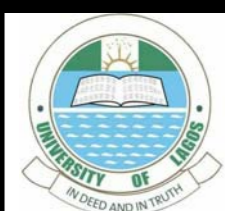
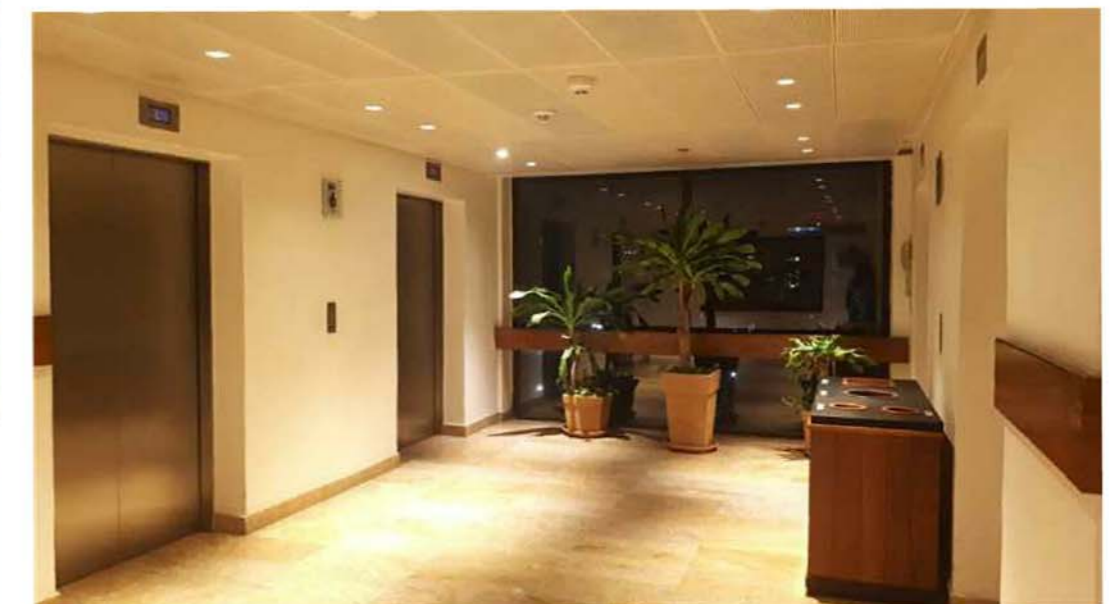
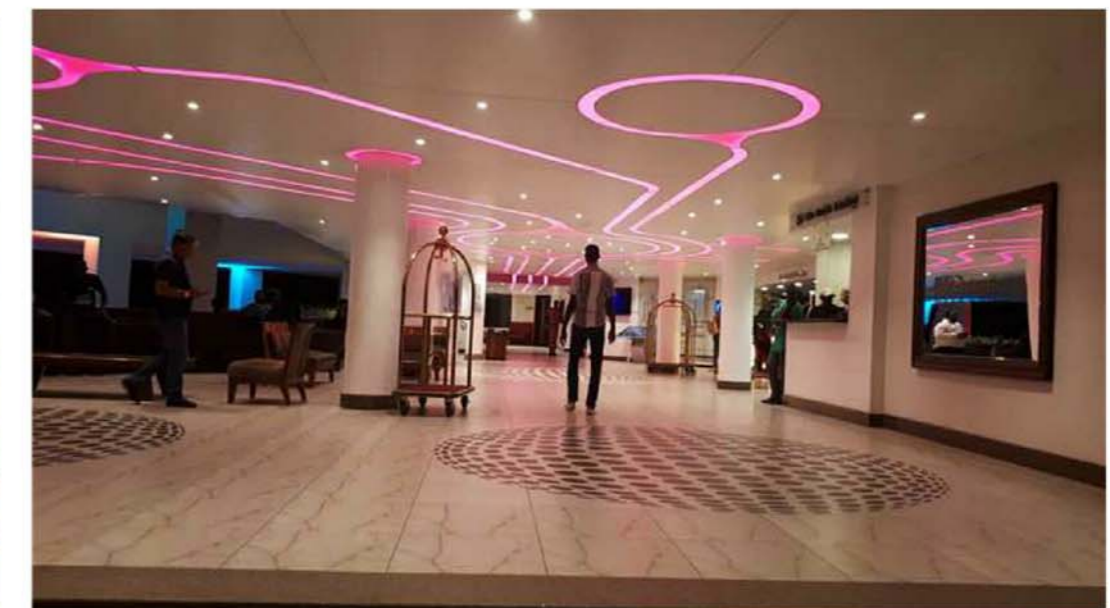
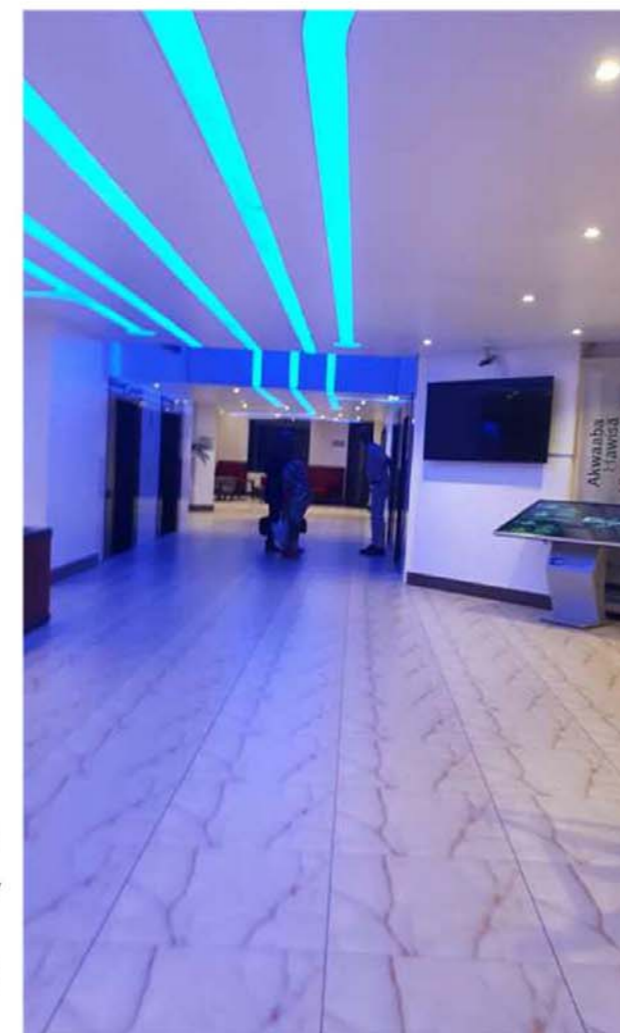

CASE STUDY II

THE MARINA BAY SANDS HOTEL SINGAPORE

Marina Bay Sands is an integrated resort fronting Marina Bay in Singapore, owned by the Las Vegas Sands corporation. At its opening in 2010, it was billed as the world's most expensive standalone casino property at \$8 billion, including the land cost and the resort was designed by Moshe Safdie.

The resort includes a 2,561room hotel, a 120, 000 square-metre (1,300,000 sq ft) convention exhibition centre, the 74,000 square metre (800, 000sq ft).

The Shoppes at Marina Bay Sands mall, a museum, two large theatres, "celebrity chef " restaurants, two floating Crystal Pavilions, art science exhibits , and the world's largest atrium casino with 500 tables and 1,600 slot machines.

The complex is topped by a 340metre long (1,120f t) Sky Park with a capacity of 3,900 people and a 150m (490f t) infinity swimming pool, set on top of the world's largest public cantilevered platform, which over hangs the north tower by 67 m (220f t) .

The 20 hectare resort was designed by Moshe Safdie architect.

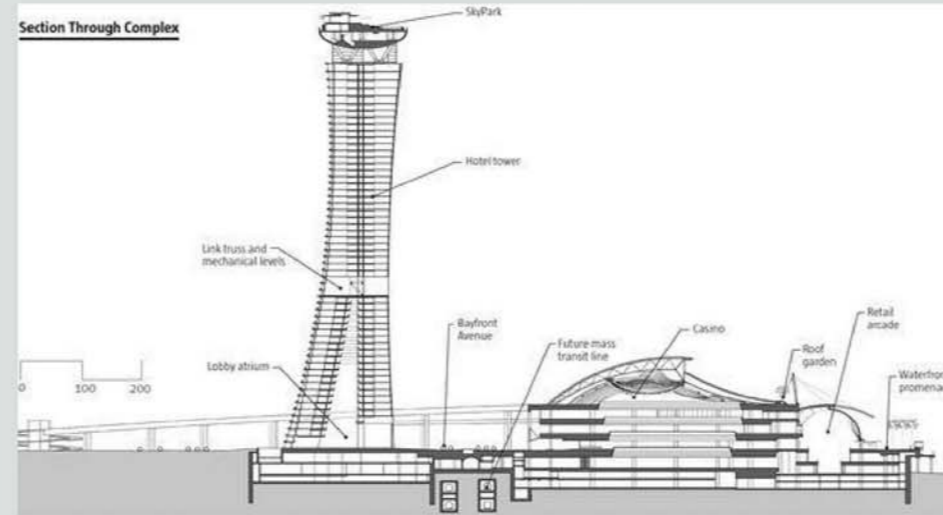

CASE STUDY III

CHICLAND HOTEL / VTN ARCHITECTS

LOCATION: DA NANG, VIETNAM SITE AREA: 699m²

CHICLAND HOTEL CREATES AN ECO CHIC LIFESTYLE - A VERY SUBTLE AND FASHIONABLE LIFE EXPERIENCE. CHICLAND HOTEL IS THE HIGHEST BUILDING IN VIETNAM COVERED WITH A VERTICAL GREENERY SYSTEM THAT IS CREATED BY LARGE PARTERRES AND BRANCHES OF INDIAN PLUCHEA, THIS MAKES THE HOTEL UNIQUE AT MY KHE BEACH, ONE OF 10TH MOST ATTRACTIVE BEACHES ON THE PLANE. TAKING INSPIRATION FROM NATURE AND GEARING TOWARD NATURE AS THE BREATH, CHICLAND HOTEL WAS BUILT WITH ALL ROOMS HAVING NATURAL LIGHT WITH HUGE WINDOWS FROM FLOOR TO CEILING TO FEEL THE WIND AND FRESH AIR OF DA NANG'S SEASIDE.

FEATURES OF THE HOTELS:

SOME IMPORTANT FEATURES OF THE HOTEL INCLUDE THE FOLLOWINGS:

- TOTAL FLOOR AREA OF 11,895 m²
- 153 ROOMS RANGING FROM STANDARD TO APARTMENT TYPE ON 21 STOREYS
- STANDARD FACILITIES SUCH AS GARAGE BASEMENT, TECHNICAL & SERVICE BASEMENT, LOBBY AREA, COFFEE HOUSE, SPA AND SKY BAR
- INFINITY ON THE ROOFTOP
- GREEN FACADE VIA THE USE OF POTTED TREES ON BALCONIES OF THE HOTEL ROOMS
- CONCRETE WALLS COVERED WITH TROPICAL GREENERY SYSTEM
- INTERIOR AND FURNITURE MATERIALS WERE MADE WITH LOCAL OR NATURAL MATERIAL: WOOD, STONE, BAMBOO, RATTAN, etc.

MERITS:

- THE USE OF ECO-FRIENDLY MATERIALS
- GREEN FACADE
- NATURAL LIGHT VENTILATION
- SPACIOUS ROOMS
- EFFICIENT DUCTING SYSTEM

DEMERITS

- SMALL KITCHEN AND STORAGE
- INADEQUATE STAFF OFFICES
- UNSTRATEGIC POSITIONING OF THE STAIRS



LONG AND WIDE WINDOWS FOR NATURAL VENTILATION AND LIGHTING

BAMBOOS AS CEILING PANELS AND VERTICAL DECORATIONS

WOODEN WALL PANEL FOR INSULATION AND THERMAL COMFORT

ECO-FRIENDLINESS AND RELEASE OF OXYGEN VIA THE GREEN FACADE

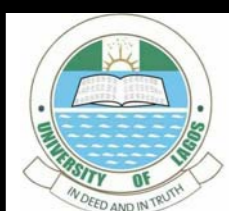
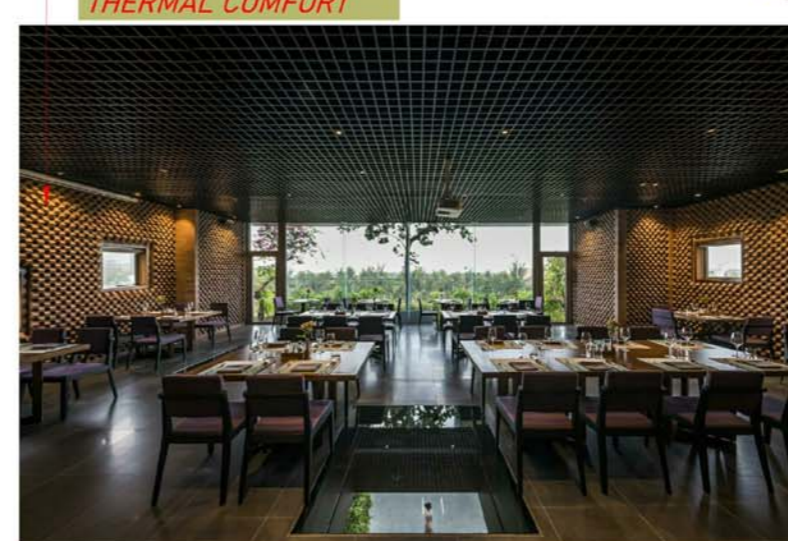
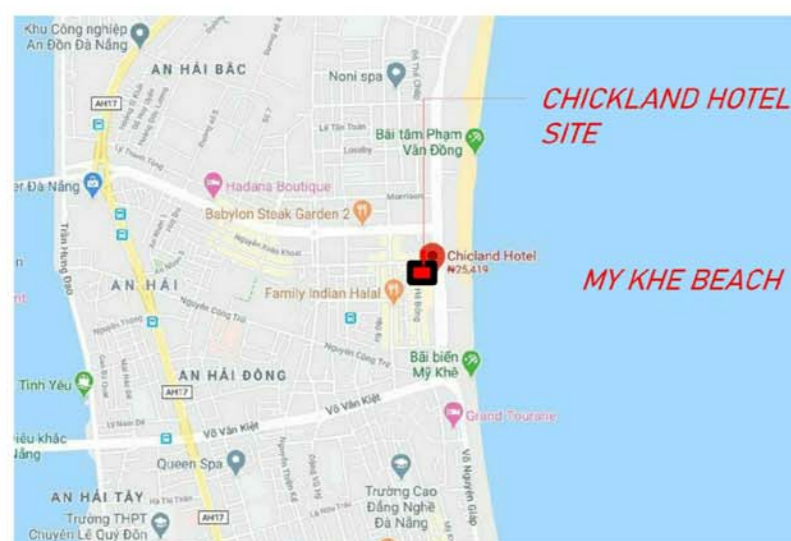

SPATIAL REQUIREMENTS & ZONNING

Different types of hotel offering varying standards of quality and facilities. Hotels may be part of a chain or independent. Where hotels do form part of a chain, special design requirements may be imposed. Hotel types include town hotels, holiday hotels, clubs, hotels with apartments and motels.

Accommodation facilities, including rooms, toilets, bathrooms, shower rooms, etc., hallways and floor service, should occupy 50 -60% of the floor area.

Site Zonning

A12

SCALE (@A2)

PUBLIC SPACES

reception
restaurant I
licensed bar
visitor toilets
function halls
shops

SEMI PRIVATE SPACES

rooms
suites
gym/spa
elevators
casino
restaurant II
restaurant III

PRIVATE SPACES

kitchens
offices
service areas
staff apartments

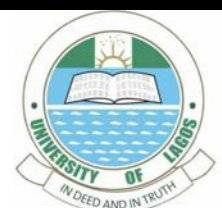

BUBBLE DIAGRAM

SPACE PROGRAMMING

Bubble Diagram

A13

SCALE (@A2)

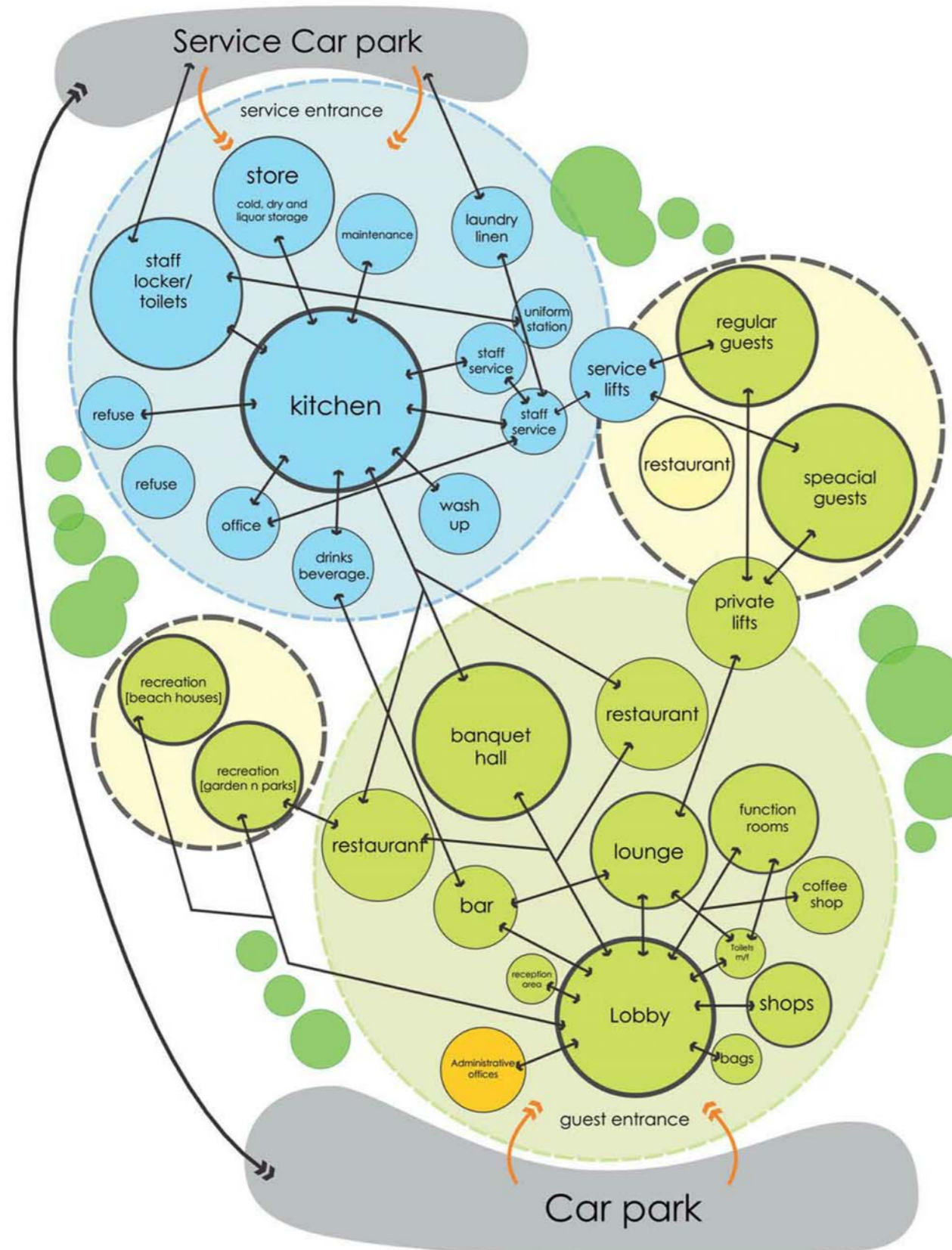

SPACES REQUIRED	Area Per Person (in m ²)	No. of Users	No. of Units	Total Area (in m ²)	Remarks
PUBLIC FACILITIES					
1. Entrance					
139.1 Ground Floor					
Port-cochere/Main Entrance	18	4	1	72.0	can accommodate 3-4 cars
Luggage Loading/Unloading	1.6	20	1	32.0	provide ramp
Valet Parking Service	0.65	4	1	2.6	provide supervisor podium
Vestibule	0.65	50	1	32.5	*optional, may be replaced by air-curtains
2. Reception Area					
372.0 Ground Floor/2nd Floor					
Grand Lobby	0.65	400	1	260.0	Ground Floor + 2nd Floor w/ Elaborate Ceiling
Front Desk/Information	2	4	1	8.0	directly accessible to incoming guests
Concierge	2	2	1	4.0	adjacent to front desk
Cashier	1.5	2	1	3.0	adjacent to front desk
Porter Service Area	1.5	4	1	6.0	close to front desk and luggage storage
Luggage Storage	1.5	10	1	15.0	racks for vertical storage may conserve floor area
Safety Deposit Boxes	1.5	10	1	15.0	enclosed room with direct access to front desk
Grand Staircase	52	1	1	52.0	2.5 m width, T-shaped
Guest Elevators	0.45	10	2	9.0	close to lounge/dining/function areas (must be central)
3. Lounging Area					
258.0 Ground Floor					
Lounge	1.5	30	1	45.0	10-20% of lobby
Atrium	150	1	1	150.0	open space for lighting & ventilation
Live Entertainment	4	2	1	8.0	for pianist, clarinet or violinist
Smoking Room	0.65	20	1	13.0	minimal seats, mostly standing
Guest Elevators	0.45	10	2	9.0	must be central
Restrooms: Male	2.5	5	1	12.5	3 water closets, 2 urinals, 1 lavatories
Restrooms: Female	2.5	5	1	12.5	3 water closets, 2 lavatories
4. Dining					
514.3 Ground Floor					
Main Dining Hall	1.8	100	1	180.0	close to main kitchen, lounge and pool areas
Buffet Serving Area	0.65	15	1	9.8	close to main kitchen
Specialty Restaurant	2	40	1	80.0	formal dining, close to specialty kitchen
Roof Deck Café	1.8	25	1	45.0	Roof Deck
Bar & Café	1.8	20	1	36.0	close wine & beverage storage
Bar Counter	2.5	3	1	7.5	
Service Entrance	1.8	5	1	9.0	can accommodate bus/trays
Circulation	0.65	100	1	65.0	hallways connecting dining areas
Auxiliary Stairs	11	1	2	22.0	stair width = 1.4m
Restrooms: Male	2.5	12	1	30.0	4 water closets, 6 urinals, 3 lavatories
Restrooms: Female	2.5	12	1	30.0	4 water closets, 4 lavatories
5. Function Halls					
1,558.5 Ground Floor and Mezzanine					
Banquet Hall	2	200	1	400.0	seated guests
Pre-function	0.65	75	1	48.8	about 30-35% of guest capacity
Theater/Seminar Hall	1.8	100	1	180.0	seated guests
Pre-function	0.65	35	1	22.8	about 30-35% of guest capacity
Function Rooms	1.8	50	4	360.0	seated guests, may be combined for larger events
Pre-function	0.65	15	1	9.8	about 30-35% of guest capacity
Meeting Rooms	1.8	20	4	144.0	seated guests, may be combined for larger events
Private Dining	1.8	12	2	43.2	seated guests, may be combined for larger events
Storage					
Chairs & Tables	20	1	1	20.0	private, but accessible to function rooms
Audio-visual Equipment/Decors	10	1	1	10.0	private, but accessible to function rooms
Circulation (Hallways plus service corridor)	0.65	400	1	260.0	hallways connecting pre-function areas
Restrooms: Male	2.5	12	1	30.0	4 water closets, 6 urinals, 3 lavatories
Restrooms: Female	2.5	12	1	30.0	4 water closets, 4 lavatories
6. Business Center					
37.5 Ground Floor					
Staff Station/Reception	2.5	2	1	5.0	desk area, computers needed
Waiting Area	2	5	1	10.0	for 3-5 persons
Telefax/Mail Station/Internet Center	2.5	6	1	15.0	5 computers, 1 telefax+printing station
Currency Exchange/Cellphone Load	2.5	1	1	2.5	small booth
ATM Machines	2.5	1	2	5.0	small booth
7. Shops					
280.0 Ground Floor					
Travel Agency	40	1	1	40.0	
Beauty Salon & Nail Spa	60	1	1	60.0	may need plumbing
Barber Shop	40	1	1	40.0	
Souvenir/Gift Shop	60	1	1	60.0	needs storage room
Wine Shop	40	1	1	40.0	needs storage room
Hallway	40	1	1	40.0	
8. Recreation and Sports Facilities					
1,704.8 Various Floors					
Lounge/Veranda	1.2	20	1	24.0	Second Floor
Atrium	120	1	1	120.0	open space for lighting & ventilation, 2nd Floor
Guest Elevators	0.45	10	2	9.0	must be central
Billiards Room	22	3	1	66.0	Second Floor
Attendant's Counter	1.8	2	3	10.8	
Video-Gaming Arcade	3	10	1	30.0	high-tech video games, 2nd Floor
Poker Club/Mini-Casino	1.8	20	1	36.0	3 tables for poker, 2 for casino
Cashier/Attendant's Counter	2.5	4	1	10.0	
Fitness Center	4	5	1	20.0	basic gym equipment, Mezzanine
Aerobics Studio	2.5	10	1	25.0	for other dance/fitness exercises, Mezzanine
Lap Pool (Indoor)	176	1	1	176.0	4 lanes, Ground Floor
Swimming Pool	300	1	1	300.0	Ground Floor, Outdoor
Pool Perimeter	246	1	1	246.0	3 meters around the pool, for benches/umbrellas
Shower w/ Lockers: Male	2.5	8	1	20.0	8 showers, includes lockers + changing area
Shower w/ Lockers: Female	2.5	8	1	20.0	8 showers, includes lockers + changing area
Restrooms: Male	2	12	1	24.0	4 water closets, 6 urinals, 3 lavatories
Restrooms: Female	2	12	1	24.0	4 water closets, 4 lavatories
Roof Deck Pool	200	1	1	200.0	Ground Floor, Outdoor
Shower w/ Lockers: Male	2.5	4	1	10.0	4 showers, includes lockers + changing area
Shower w/ Lockers: Female	2.5	4	1	10.0	4 showers, includes lockers + changing area
Restrooms: Male	2	6	1	12.0	2 water closets, 3 urinals, 2 lavatories
Restrooms: Female	2	6	1	12.0	4 water closets, 2 lavatories
Meditation and Zen Garden	300	1	1	300.0	Roof Deck
Viewing Deck	100	1	1	100.0	Roof Deck, attached to zen garden
Putting Lawn (Mini-Golf Course)	450	1	1	450.0	Ground Level, outdoor
Lawn Tennis	450	1	1	450.0	Ground Level, outdoor

SPACES REQUIRED	Area Per Person (in m ²)	No. of Users	No. of Units	Total Area (in m ²)	Remarks
ROOM ACCOMMODATIONS					
11,435.0 inclusive of circulation					
9. Guest Rooms					
250 10,413.0 3rd-6th Floors; total should be 250					
Standard Rooms (single/double)	27	1	80	2,160.0	two single beds or one double-bed
De Luxe Rooms (single/double)	31	1	81	2,511.0	similar to standard rooms
Family De Luxe Rooms	40	1	80	3,200.0	two double beds or two single plus one double-bed
Bridal Suite	40	1	1	2,080.0	matrimonial bed, guest area, large toilet & bath
Executive Suite	48	1	5	240.0	king size bed, office/study area, pantry/kitchenette
Residence Suite	68	1	2	136.0	two rooms, living/dining, pantry/kitchenette
Presidential Suite	86	1	1	86.0	executive suite plus additional room, occupies two floors
10. Circulation					
1,022.0 Various Floors					
Service Elevators	0.45	10	4	18.0	number of elevator = 1 elevator x 4 floors
Guest Elevators	0.45	10	8	36.0	number of elevators = 2 elevators x 4 floors
Auxiliary Stairs	11	1	4	44.0	4 floors, stair width = 1.4 m
Corridors & Hallways	216	1	4	864.0	1.5m-1.8m, depending on length of corridor
Fire Exits	7.5	1	8	60.0	2 stairs x 4 floors, stair width = 1 m
OFFICES & PERSONNEL AREA					
631.2					
11. Front Office					
40.0 G/F, partially private, partially open					
Front Office Manager	5	1	1	5.0	private
Customer Service Director	5	1	1	5.0	private
Housekeeping Manager	5	1	1	5.0	private
Front Office Supervisor	5	1	1	5.0	private, with window to front desk
Front Desk Agents	2.5	3	1	7.5	opens to reception
Telephone Operator	2.5	1	1	2.5	private
Reservations Supervisor	2.5	1	1	2.5	private, with window to front desk
Reservations Agents	2.5	3	1	7.5	private
12. Hotel Administration Office					
276.4					
Waiting Area/Reception	2.5	4	1	10.0	
General Manager's Office	20	1	1	20.0	private office w/ own restroom
Assistant Manager	9.3	1	1	9.3	
Executive Secretary	7	1	1	7.0	
Human Resources Director	15	1	1	15.0	private office
Personnel Manager	9.3	1	1	9.3	
HR Clerks	5	3	1	15.0	
Sales & Marketing Manager	15	1	1	15.0	private office
Sales/Catering Director	7	1	1	7.0	
Catering Manager	7	1	1	7.0	
Sales & Marketing Assistants	5	3	1	15.0	
Finance Director	15	1	1	15.0	private office
Accounting Head	9.3	1	1	9.3	
Accounting Clerks	5	3	1	15.0	
Bookkeeper	5	2	1	10.0	
Auditor	7	1	1	7.0	
Purchasing Manager	7	1	1	7.0	
Purchasing Assistants	5	2	1	10.0	
General Office Clerks	2.5	5	1	12.5	
Conference Room	2.4	10	1	24.0	central to offices
Pantry/Kitchenette	0.65	20	1	13.0	
Restrooms: Male	2	6	1	12.0	2 water closets, 2 urinals, 2 lavatories
Restrooms: Female	2	6	1	12.0	3 water closets, 2 lavatories
13. Food & Beverage Office					
77.3					
Food & Beverage Director	15	1	1	15.0	private office
Dietician	9.3	1	1	9.3	
Banquet Manager	7	3	1	21.0	
Banquet Captain	5	2	1	10.0	
Executive Chef	7	1	1	7.0	
Sous Chef/Kitchen Supervisor	5	1	1	5.0	
Restaurant Supervisor	5	1	1	5.0	
Bar Supervisor	5	1	1	5.0	
14. Staff Common Area					
237.5					
Employees' Entrance	0.65	60	1	39.0	includes security check, bundy clock, etc.
Staff Lounge	1.2	15	1	18.0	
Staff Dining Area/Cafeteria	1.8	20	1	36.0	
Kitchen/Pantry	2.5	4	1	10.0	
Changing Room Male	2	10	1	20.0	
Changing Room Female	2	10	1	20.0	
Lockers	0.45	10	1	4.5	for entry-level staff & maintenance personnel
Hallways & Corridors (Circulation)	50	1	1	50.0	1.2m-1.5m wide, depending on traffic load
Restrooms: Male	2	10	1	20.0	3 water closets, 3 urinals, 2 lavatories
Restrooms: Female	2	10	1	20.0	4 water closets, 2 lavatories
15. Senior Management Flat					
76.5 2/F					
General Manager's Room	20	1	1	20.0	w/ private toilet & bath
Senior Managers' Rooms	20	1	2	40.0	includes 1 shared toilet & bath
Pantry/Kitchenette	7.5	1	1	7.5	
SERVICE FACILITIES					
733.7					
16. Food & Beverage					
406.8					
Main Kitchen	100	1	1	100.0	about 30% of total dining area
Auxiliary Kitchen	90	1	1	90.0	about 10% of total function area
Specialty Kitchen	25	1	1	25.0	about 30% of specialty restaurant area
Quality Check/Service Station	2.5	3	1	7.5	area to check plating, etc.
Waiter Pick-up & Dish Return	0.75	10	1	7.5	counter area
Waiters' Assembly Area	0.65	15	1	9.8	for inspection/instructions
Dishwashing Station	2	1	5	10.0	
Kitchenware & Utensils Storage	10	1	1	10.0	
Pantry	30	1	1	30.0	
Supply Releasing Desk	2.5	2	1	5.0	
Wine & Beverage Storage	20	1	1	20.0	
Supplies Delivery	18	1	1	18.0	2 x 9 m
Docking Station	18	1	3	54.0	3 delivery van
Receiving Office	12	1	1	12.0	
Waste Disposal	2	1	4	8.0	one in each kitchen plus 1 in dishwashing station

SOREMI BOLUWATIFE G. 140501024 ADVANCED DESIGN STUDIO FIVE STAR HOTEL

Meniru Emmanuel Chidiebube 199051003

MED 1 Architecture May, 2021

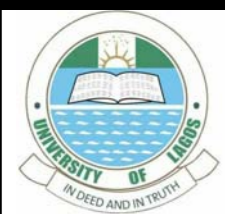

City Center 5 Star Hotel At Marina Lagos



ARC 801
Advanced Design Studio 1

CRITICS: Prof. Adebamowo, Dr. Adejumo, Dr. Obi, Dr. Jobi
Dr. Omoegun, Arc. Savage, Arc. Ajose-Adeogun
Arc. Williams

CONCEPTUAL DEVELOPMENT



LUXURY YATCH



Podium Concept



LUXURY YATCH

+



TOWER

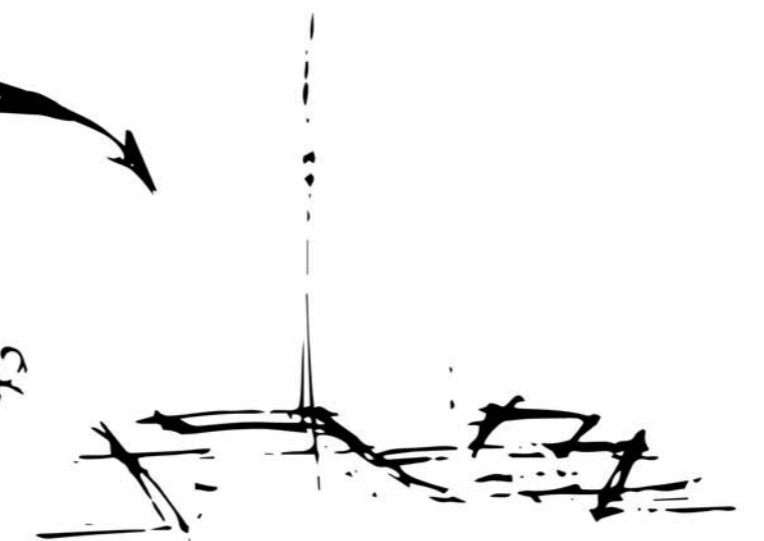

AL BAHAR TOWER
With Kinetic facade



Tower Concept derivation

LUXURY FOR ALL

KEYWORDS FROM BRIEF

- * LUXURY
- * ICONIC
- * ALL AND SUNDRY

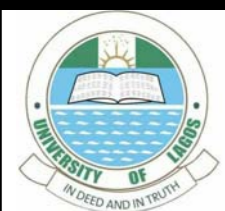

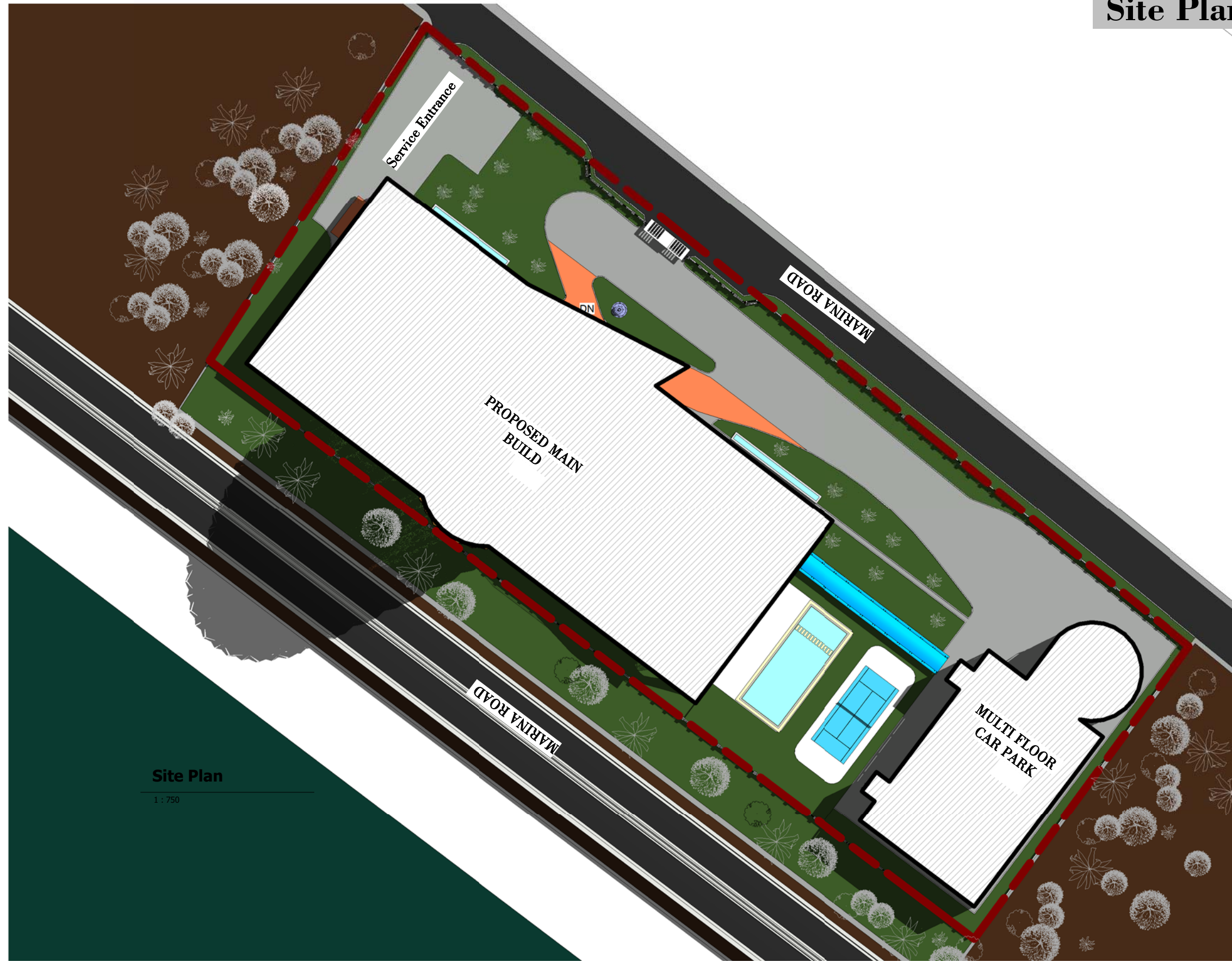
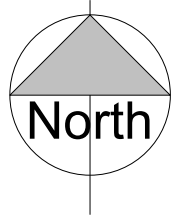

Meniru Emmanuel Chidiebube 199051003

MED 1 Architecture May , 2021

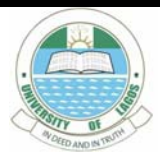

City Center 5 Star Hotel At Marina Lagos



ARC 801
Advanced Design Studio 1

CRITICS: Prof. Adebamowo, Dr. Adejumo, Dr. Obi, Dr. Jobi
Dr. Omoegun, Arc. Savage, Arc. Ajose-Adeogun
Arc. Williams

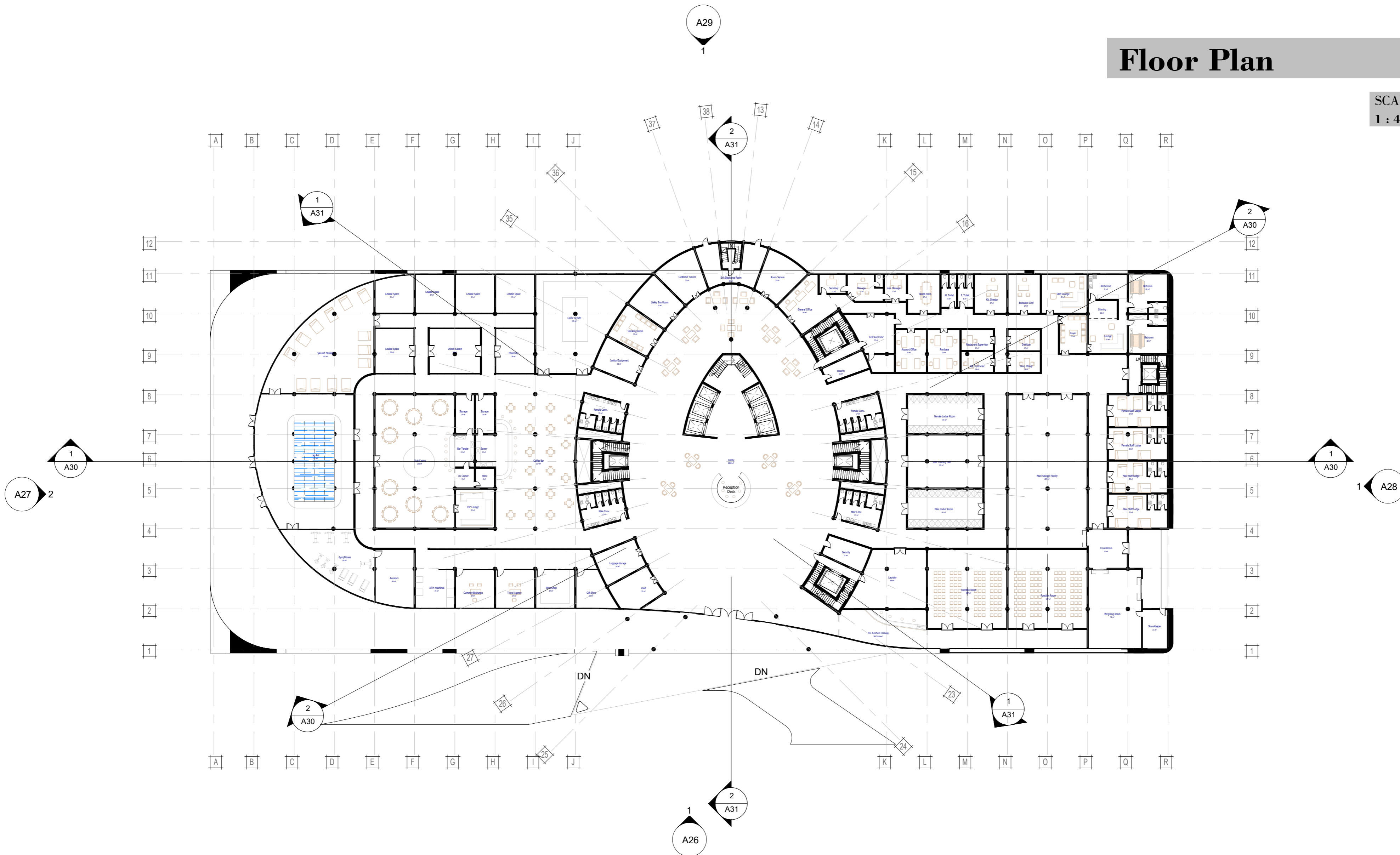

00_Ground Floor

1 : 400

Meniru Emmanuel Chidiebube 199051003

MED 1 Architecture May , 2021

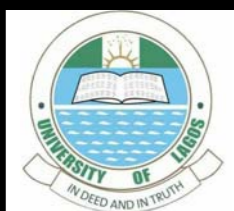

City Center 5 Star Hotel At Marina Lagos



ARC 801 Advanced Design Studio 1

CRITICS: Prof. Adebamowo, Dr. Adejumo, Dr. Obi, Dr. Jobi
Dr. Omoegun, Arc. Savage, Arc. Ajose-Adeogun
Arc. Williams

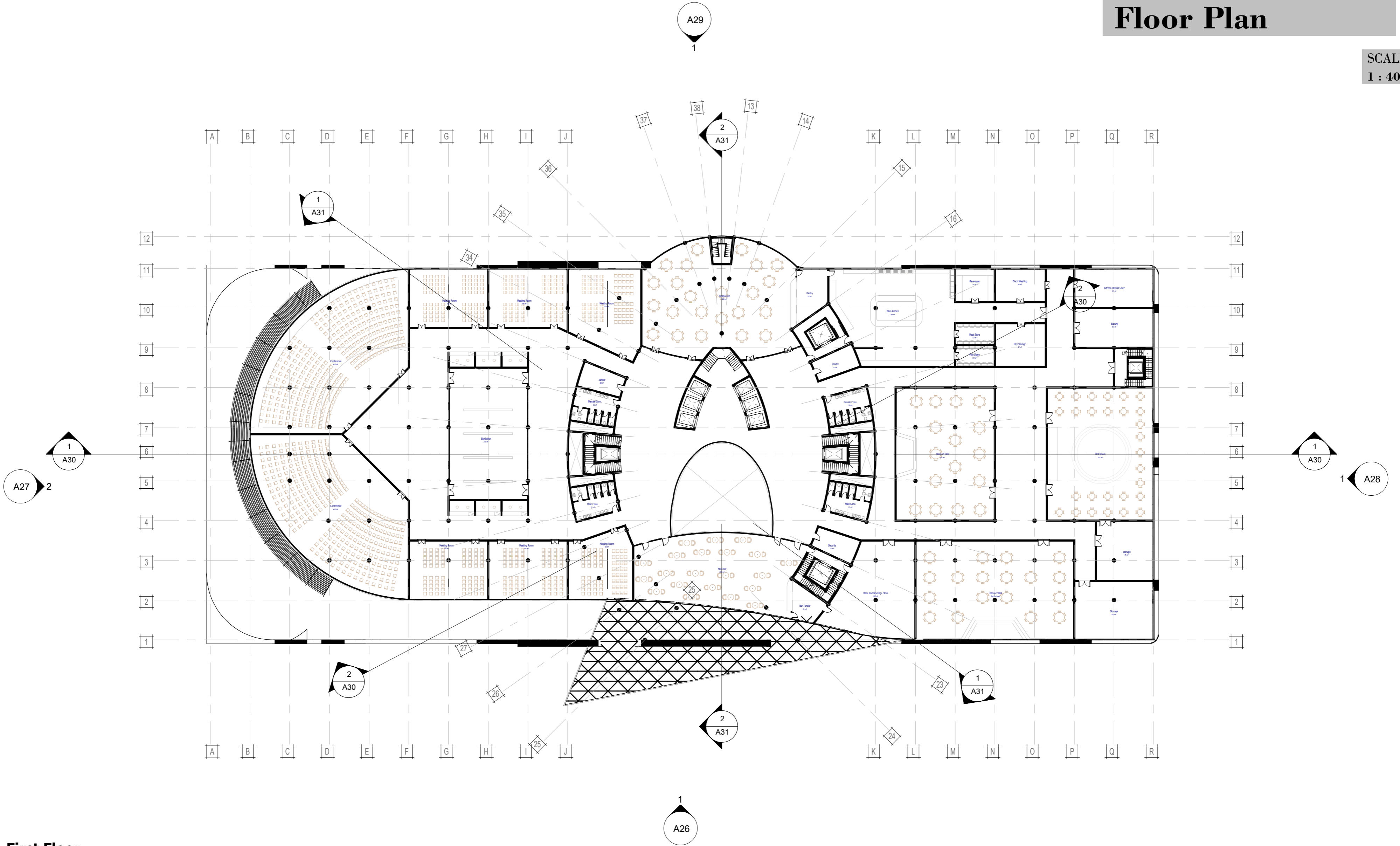

01_First Floor

1 : 400

Meniru Emmanuel Chidiebube 199051003

MED 1 Architecture May , 2021

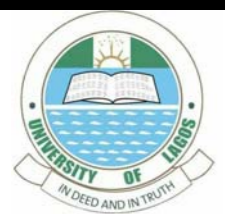

City Center 5 Star Hotel At Marina Lagos



ARC 801 Advanced Design Studio 1

CRITICS: Prof. Adebamowo, Dr. Adejumo, Dr. Obi, Dr. Jobi
Dr. Omoegun, Arc. Savage, Arc. Ajose-Adeogun
Arc. Williams

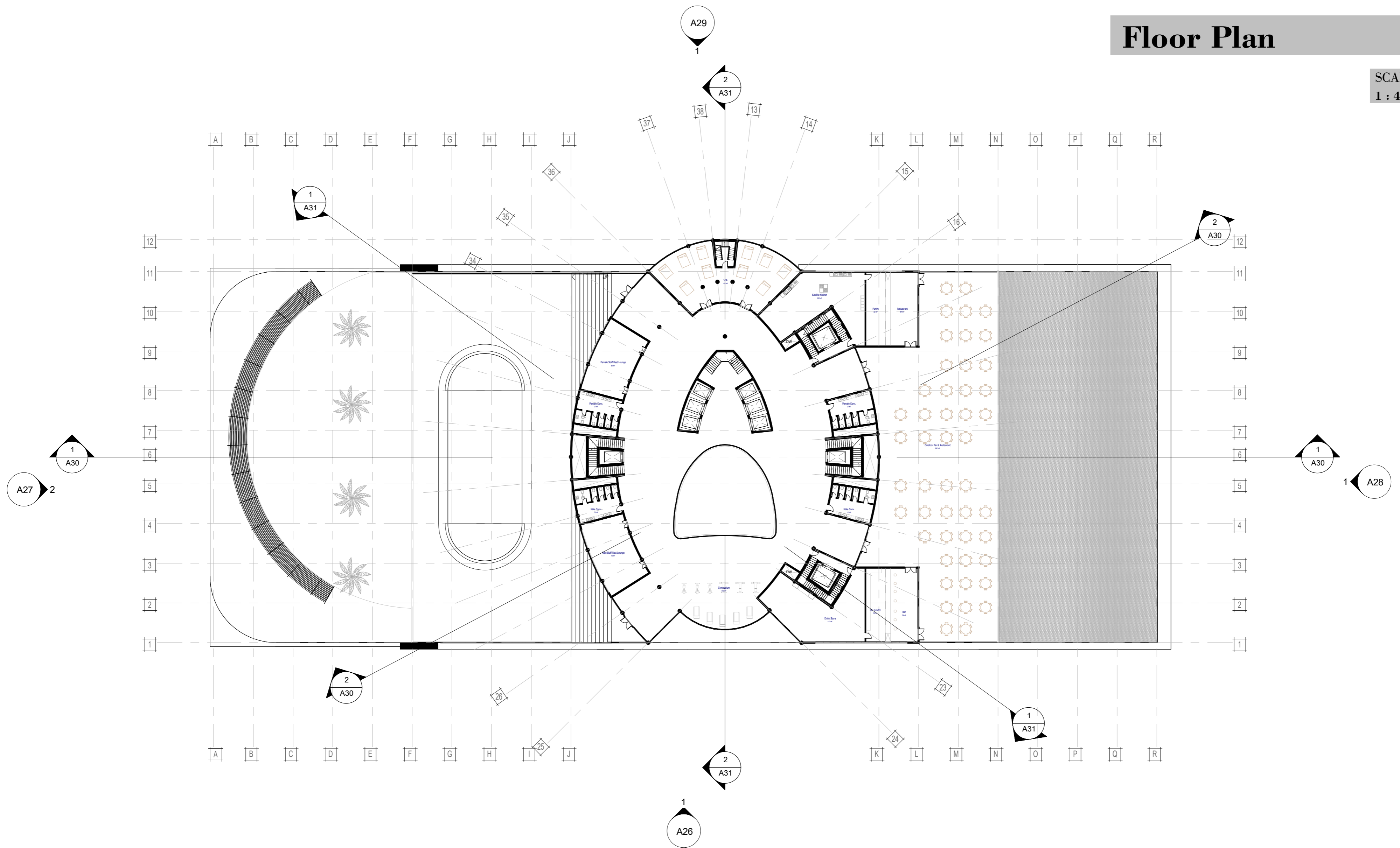

02_Second Floor

1 : 400

Meniru Emmanuel Chidiebube 199051003

MED 1 Architecture May , 2021

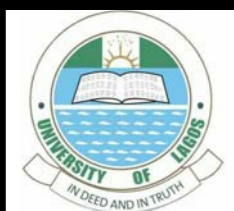

City Center 5 Star Hotel At Marina Lagos



ARC 801
Advanced Design Studio 1

CRITICS: Prof. Adebamowo, Dr. Adejumo, Dr. Obi, Dr. Jobi
Dr. Omoegun, Arc. Savage, Arc. Ajose-Adeogun
Arc. Williams

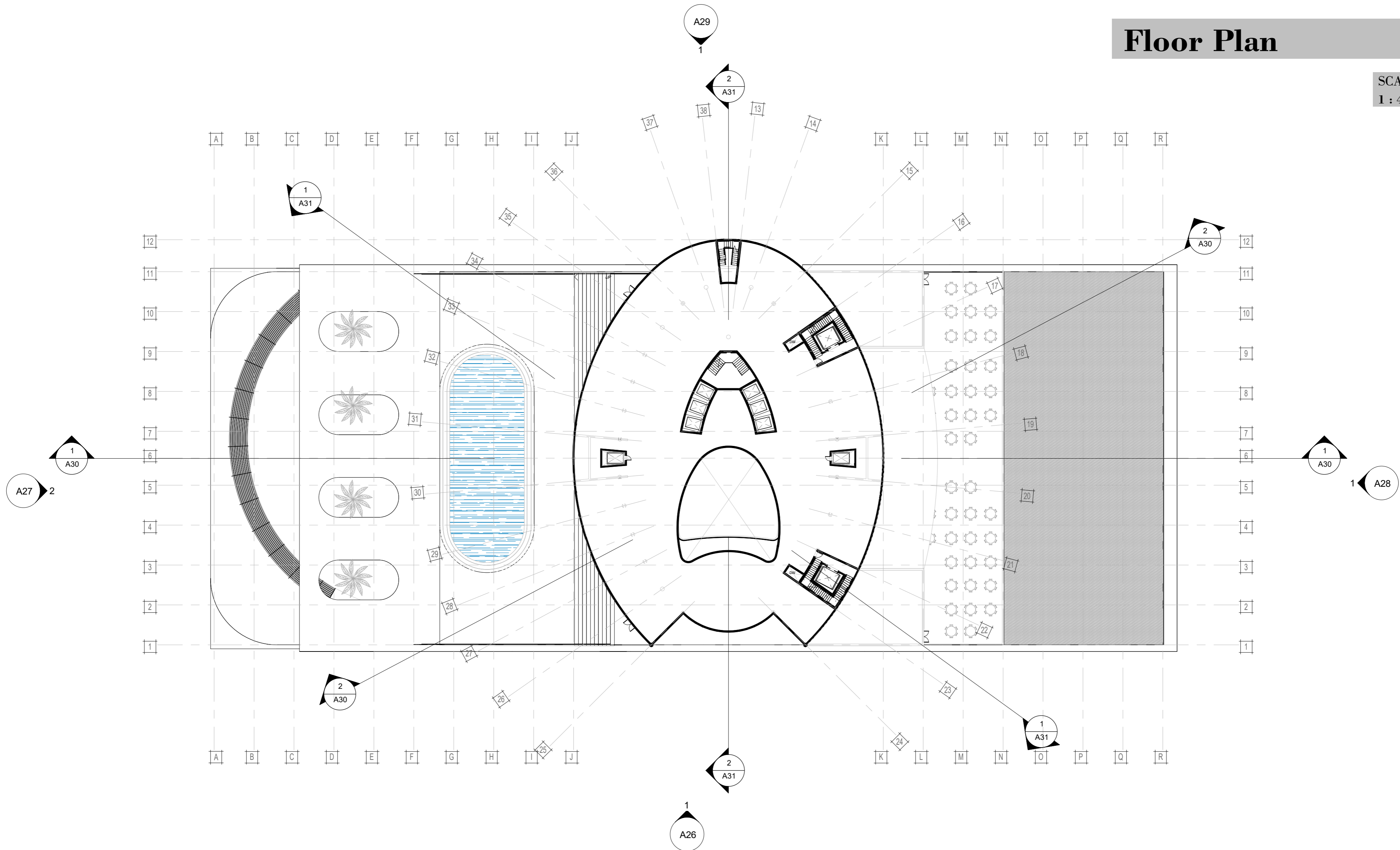

03_Third Floor (Service Floor 1)

1 : 400

Meniru Emmanuel Chidiebube 199051003

MED 1 Architecture May , 2021

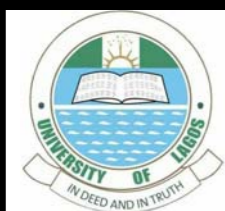

City Center 5 Star Hotel At Marina Lagos



ARC 801
Advanced Design Studio 1

CRITICS: Prof. Adebamowo, Dr. Adejumo, Dr. Obi, Dr. Jobi
Dr. Omoegun, Arc. Savage, Arc. Ajose-Adeogun
Arc. Williams

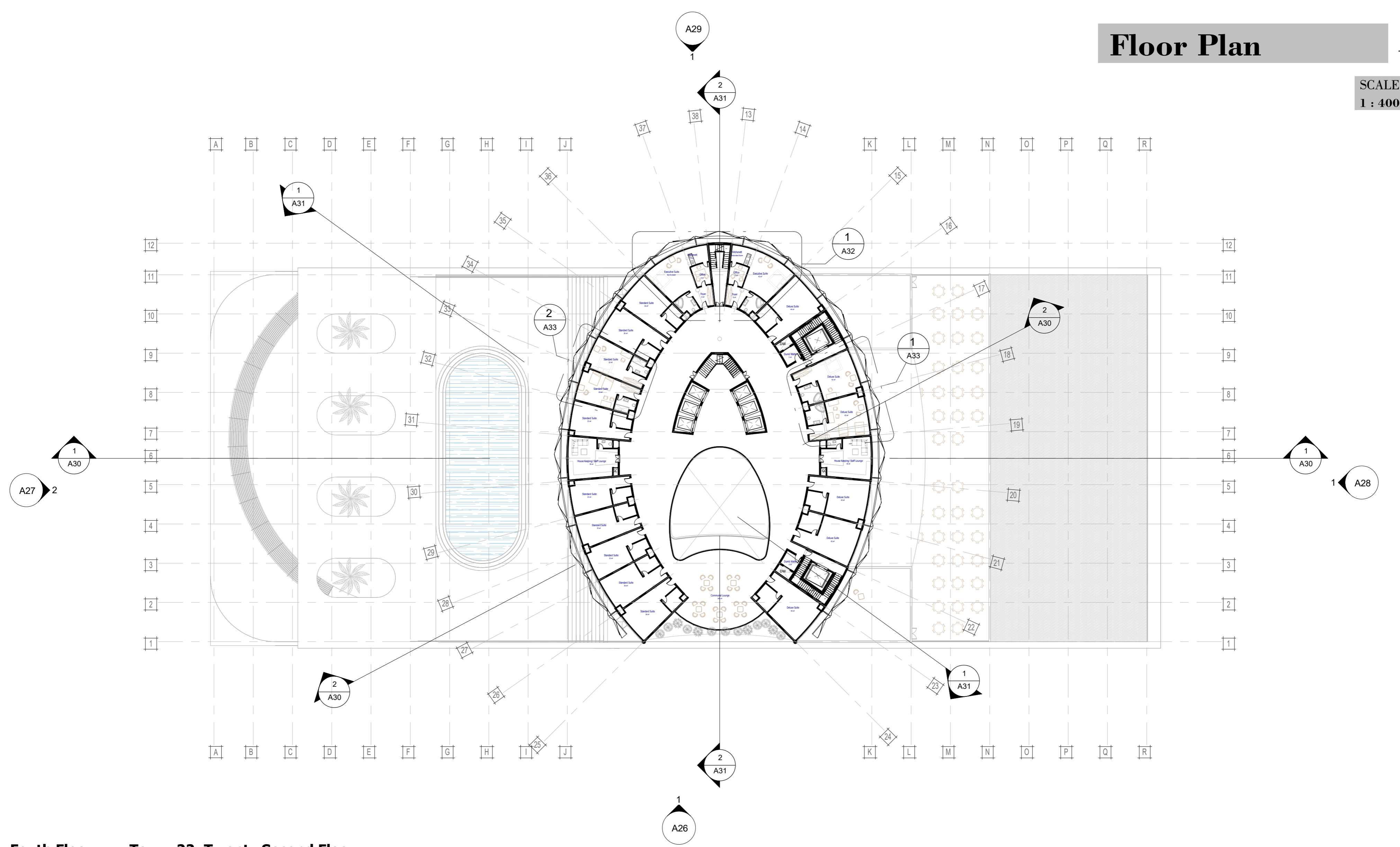

04_Fouth Floor To 22_Twenty Second Floor

1 : 400

Meniru Emmanuel Chidiebube 199051003

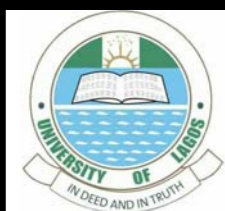

City Center 5 Star Hotel At Marina Lagos



ARC 801 Advanced Design Studio 1

MED 1 Architecture May , 2021

CRITICS: Prof. Adebamowo, Dr. Adejumo, Dr. Obi, Dr. Jobi
Dr. Omoegun, Arc. Savage, Arc. Ajose-Adeogun
Arc. Williams

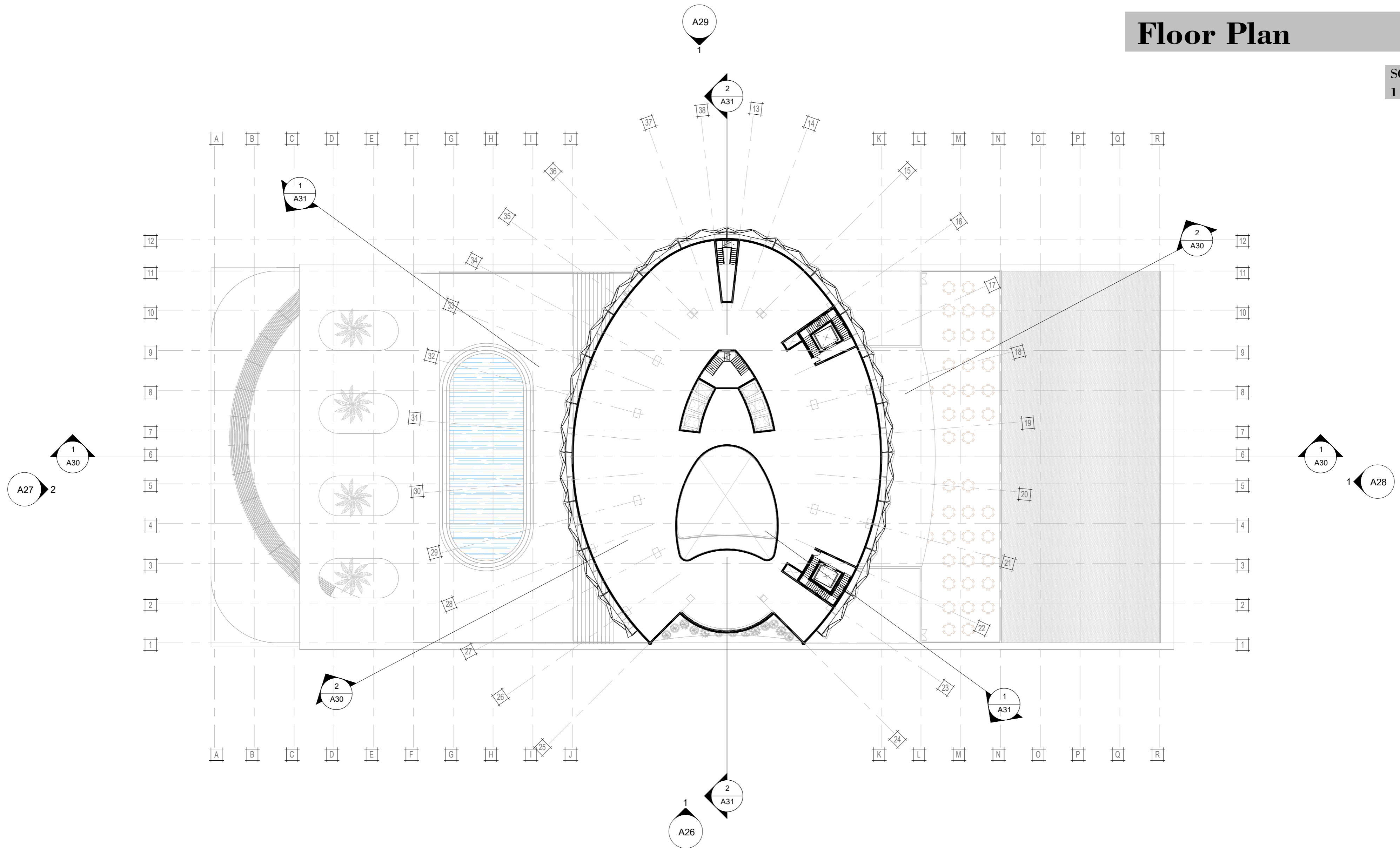

23_Twenty Third Floor (Service Floor 2)

1 : 400

Meniru Emmanuel Chidiebube 199051003

MED 1 Architecture May , 2021

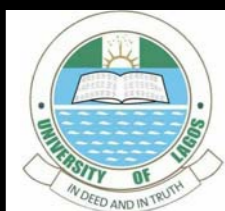

City Center 5 Star Hotel At Marina Lagos



ARC 801
Advanced Design Studio 1

CRITICS: Prof. Adebamowo, Dr. Adejumo, Dr. Obi, Dr. Jobi
Dr. Omoegun, Arc. Savage, Arc. Ajose-Adeogun
Arc. Williams

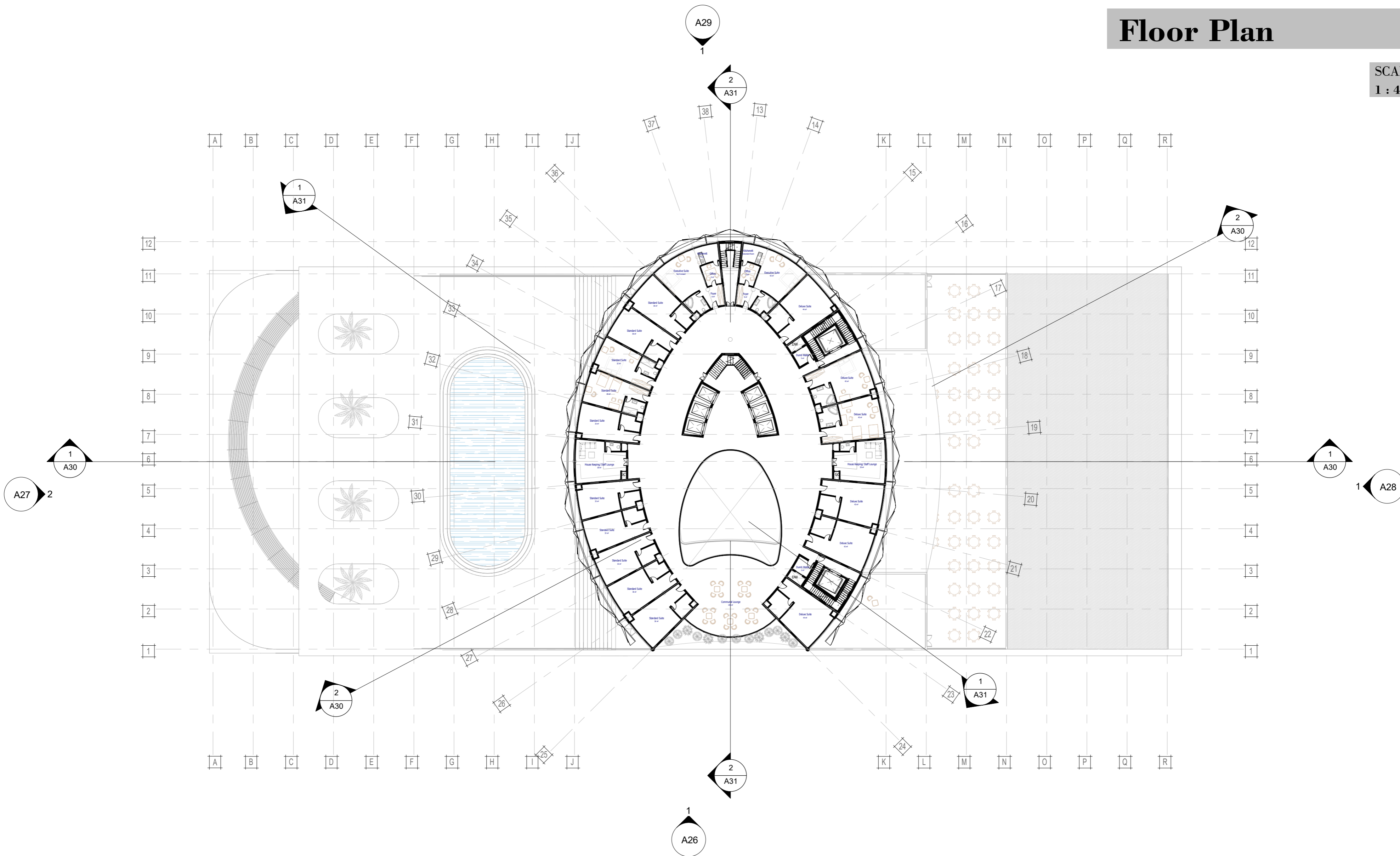

24_Twenty Fourth Floor To 37_Thirty Seventh Floor

1 : 400

Meniru Emmanuel Chidiebube 199051003

MED 1 Architecture May , 2021

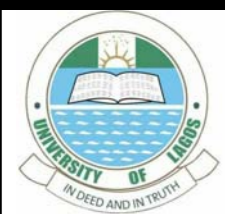

City Center 5 Star Hotel At Marina Lagos



ARC 801
Advanced Design Studio 1

CRITICS: Prof. Adebamowo, Dr. Adejumo, Dr. Obi, Dr. Jobi
Dr. Omoegun, Arc. Savage, Arc. Ajose-Adeogun
Arc. Williams

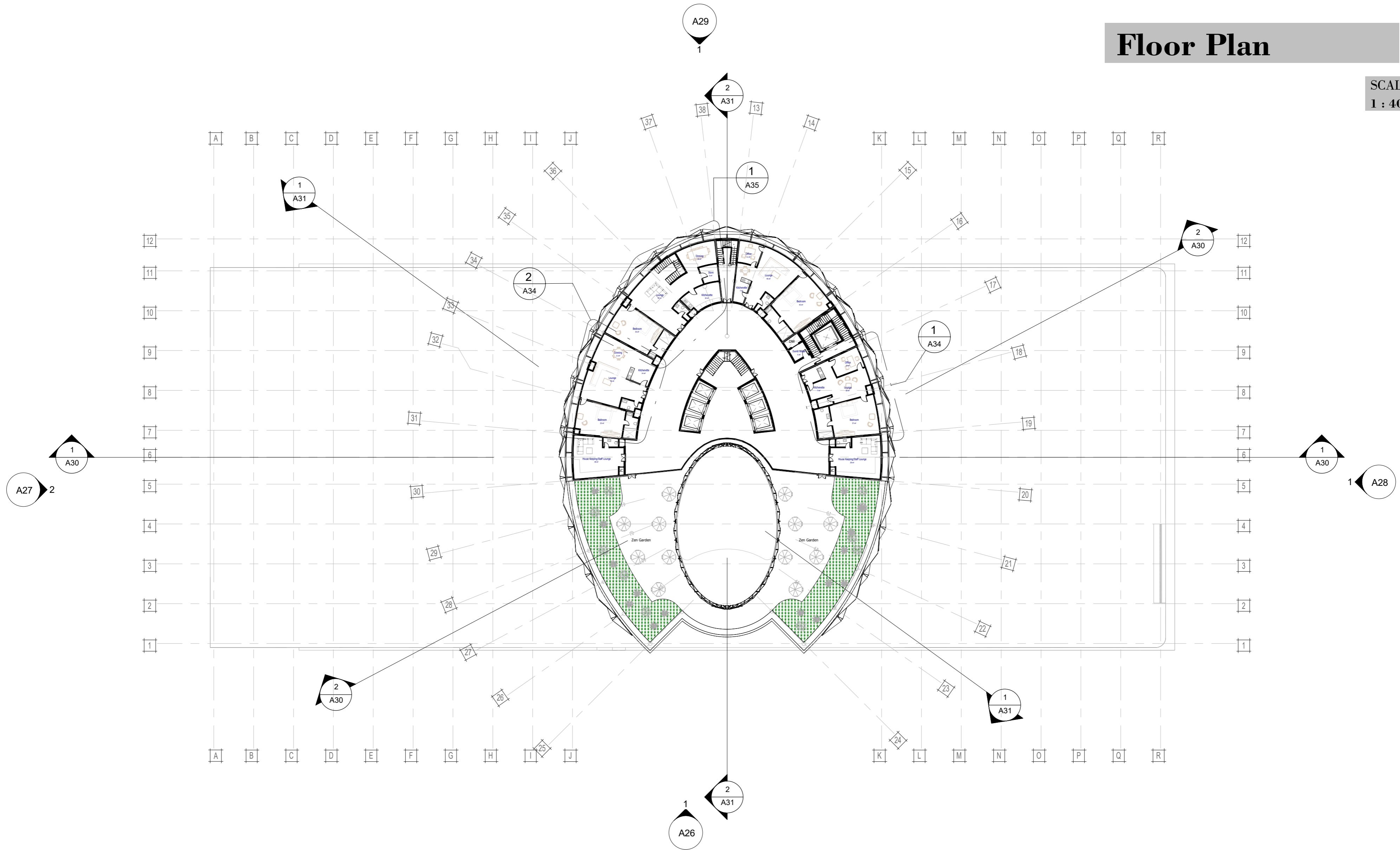

38_Thirty Eighth Floor

1 : 400

Meniru Emmanuel Chidiebube 199051003

MED 1 Architecture May , 2021

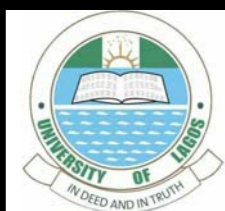

City Center 5 Star Hotel At Marina Lagos



ARC 801
Advanced Design Studio 1

CRITICS: Prof. Adebamowo, Dr. Adejumo, Dr. Obi, Dr. Jobi
Dr. Omoegun, Arc. Savage, Arc. Ajose-Adeogun
Arc. Williams

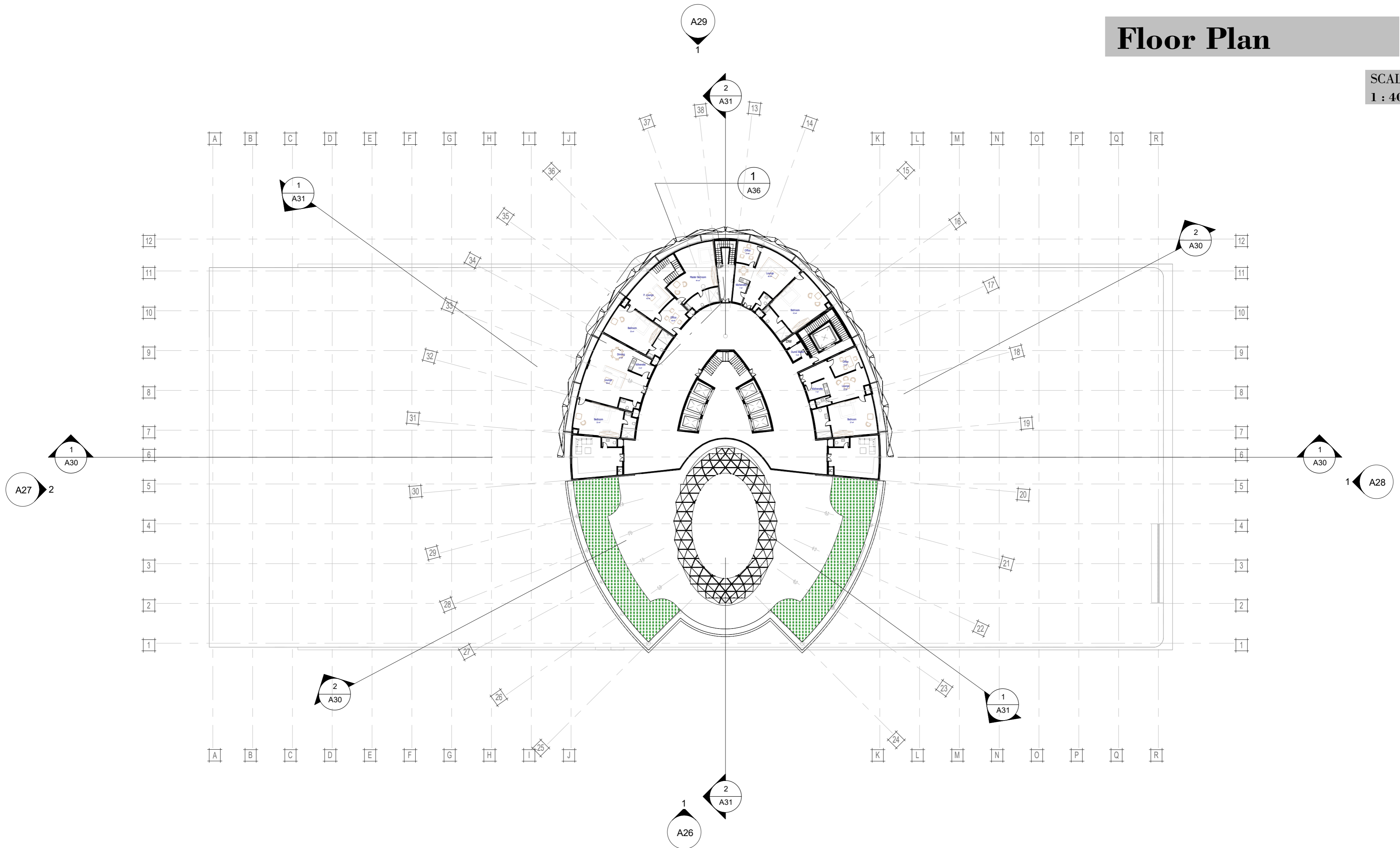

39_Thirty Ninth Floor

1 : 400

Meniru Emmanuel Chidiebube 199051003

MED 1 Architecture May , 2021

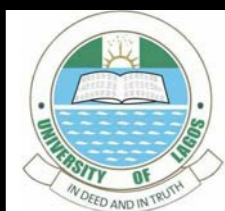

City Center 5 Star Hotel At Marina Lagos



ARC 801
Advanced Design Studio 1

CRITICS: Prof. Adebamowo, Dr. Adejumo, Dr. Obi, Dr. Jobi
Dr. Omoegun, Arc. Savage, Arc. Ajose-Adeogun
Arc. Williams

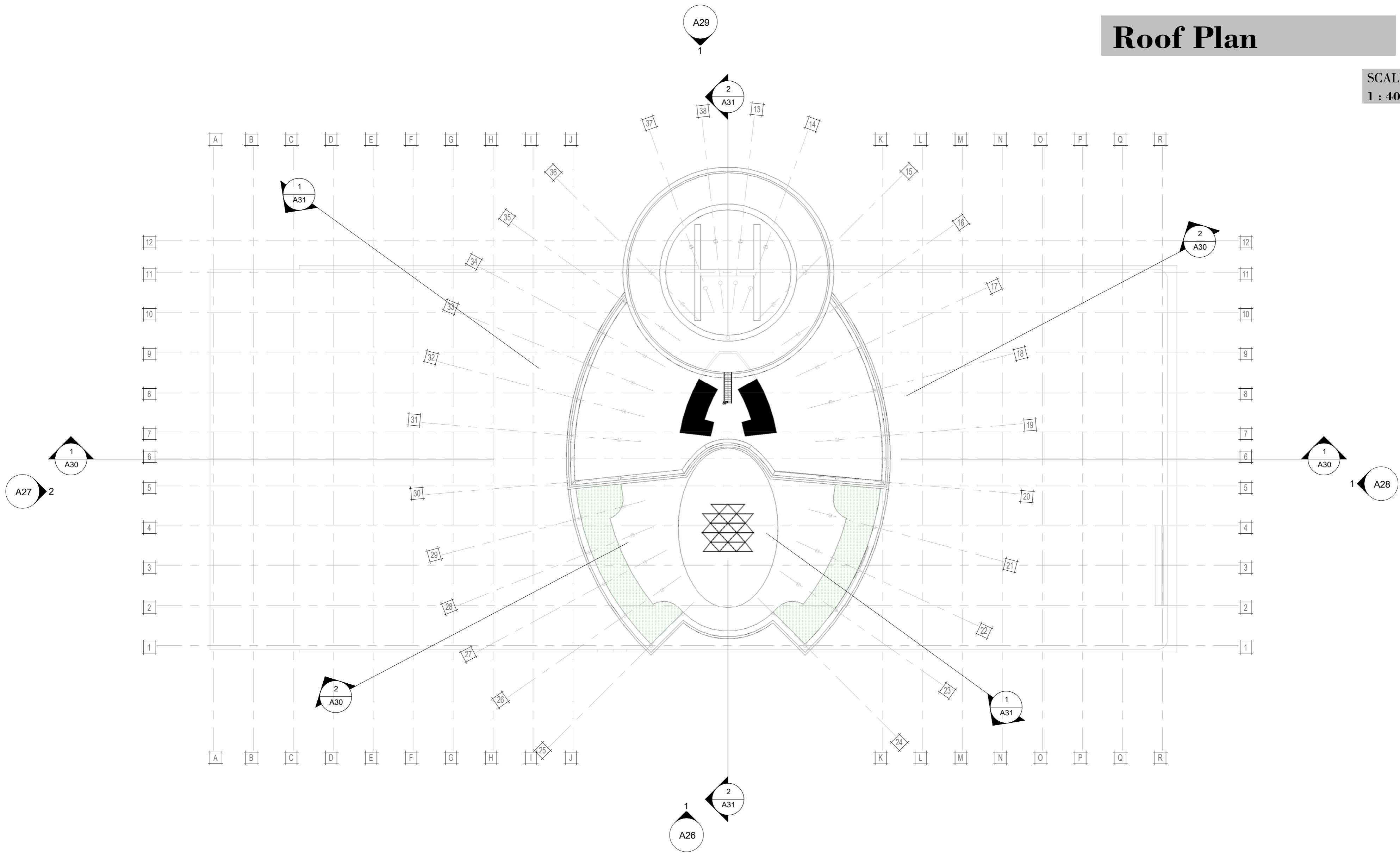

40_Roof Level

1 : 400

Meniru Emmanuel Chidiebube 199051003

MED 1 Architecture May , 2021

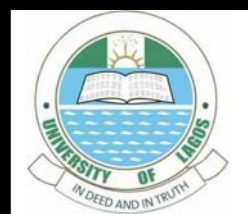

City Center 5 Star Hotel At Marina Lagos



ARC 801 Advanced Design Studio 1

CRITICS: Prof. Adebamowo, Dr. Adejumo, Dr. Obi, Dr. Jobi
Dr. Omoegun, Arc. Savage, Arc. Ajose-Adeogun
Arc. Williams

A B C D E F G H I J K L M N O P Q R

Elevation

A26

SCALE (@A2)
1 : 600



- 40 Roof Level
166200
- 39 Thirty Ninth Floor
162200
- 38 Thirty Eighth Floor
158200
- 37 Thirty Seventh Floor
154200
- 36 Thirty Sixth Floor
150200
- 35 Thirty Fifth Floor
146200
- 34 Thirty Fourth Floor
142200
- 33 Thirty Third Floor
138200
- 32 Thirty Second Floor
134200
- 31 Thirty First Floor
130200
- 30 Thirtieth Floor
126200
- 29 Twenty Ninth Floor
122200
- 28 Twenty Eighth Floor
118200
- 27 Twenty Seventh Floor
114200
- 26 Twenty Sixth Floor
110200
- 25 Twenty Fifth Floor
106200
- 24 Twenty Fourth Floor
102200
- 23 Twenty Third Floor
98200
- 22 Twenty Second Floor
94200
- 21 Twenty First Floor
90200
- 20 Twentieth Floor
86200
- 19 Nineteenth Floor
82200
- 18 Eighteenth Floor
78200
- 17 Seventeenth Floor
74200
- 16 Sixteenth Floor
70200
- 15 Fifteenth Floor
66200
- 14 Fourteenth Floor
62200
- 13 Thirteenth Floor
58200
- 12 Twelfth Floor
54200
- 11 Eleventh Floor
50200
- 10 Tenth Floor
46200
- 09 Ninth Floor
42200
- 08 Eight Floor
38200
- 07 Seventh Floor
34200
- 06 Sixth Floor
30200
- 05 Fifth Floor
26200
- 04 Fourth Floor
22200
- 03 Third Floor
19200
- 02 Second Floor
13200
- 01 First Floor
7200
- 00 Ground Floor
1200 Actual Ground Level

South Elevation

1 : 600

Meniru Emmanuel Chidiebube 199051003

MED 1 Architecture May , 2021

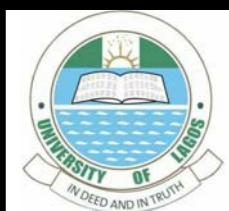

City Center 5 Star Hotel At Marina Lagos



ARC 801
Advanced Design Studio 1

CRITICS: Prof. Adebamowo, Dr. Adejumo, Dr. Obi, Dr. Jobi
Dr. Omoegun, Arc. Savage, Arc. Ajose-Adeogun
Arc. Williams

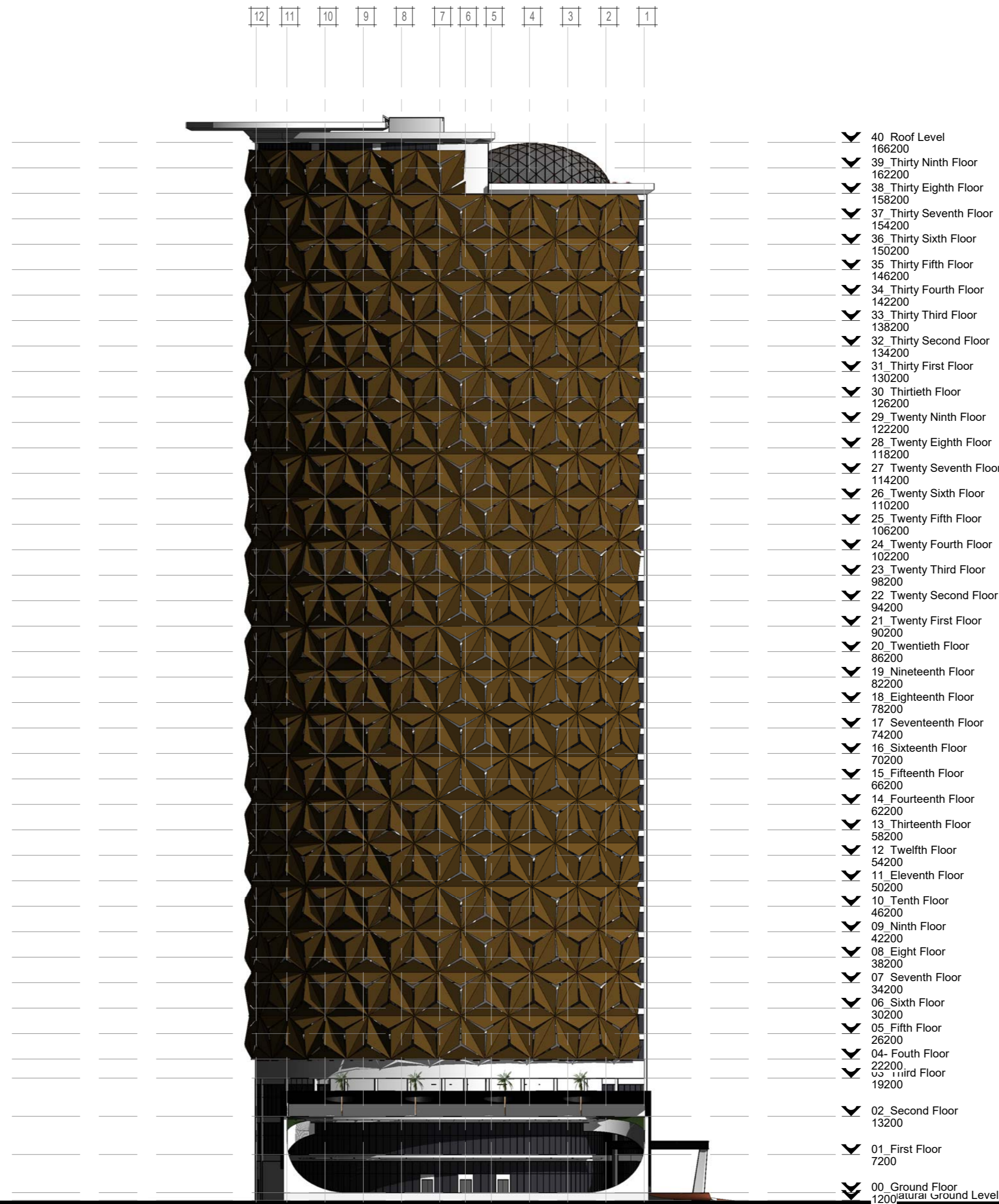

West Elevation

1 : 600

Meniru Emmanuel Chidiebube 199051003

MED 1 Architecture May , 2021

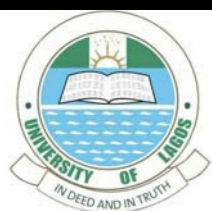

City Center 5 Star Hotel At Marina Lagos



ARC 801
Advanced Design Studio 1

CRITICS: Prof. Adebamowo, Dr. Adejumo, Dr. Obi, Dr. Jobi
Dr. Omoegun, Arc. Savage, Arc. Ajose-Adeogun
Arc. Williams

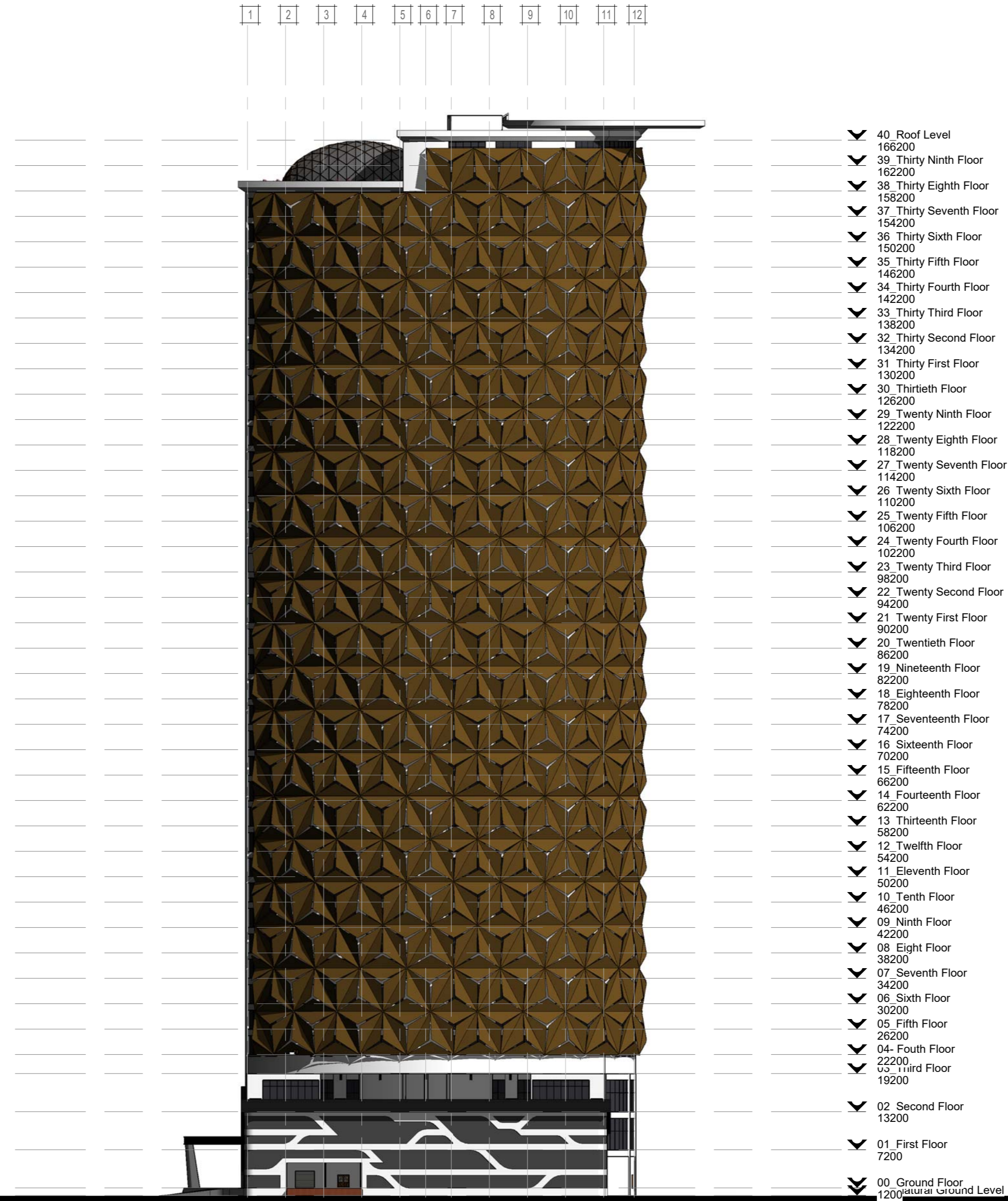

East elevation

1 : 600

Meniru Emmanuel Chidiebube 199051003

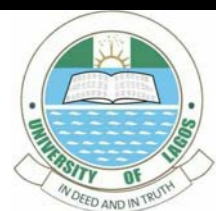

City Center 5 Star Hotel At Marina Lagos



ARC 801 Advanced Design Studio 1

MED 1 Architecture May , 2021

CRITICS: Prof. Adebamowo, Dr. Adejumo, Dr. Obi, Dr. Jobi
Dr. Omoegun, Arc. Savage, Arc. Ajose-Adeogun
Arc. Williams

R Q P O N M L K

J I H G F E D C B A

Elevation

A29

SCALE (@A2)
1 : 600

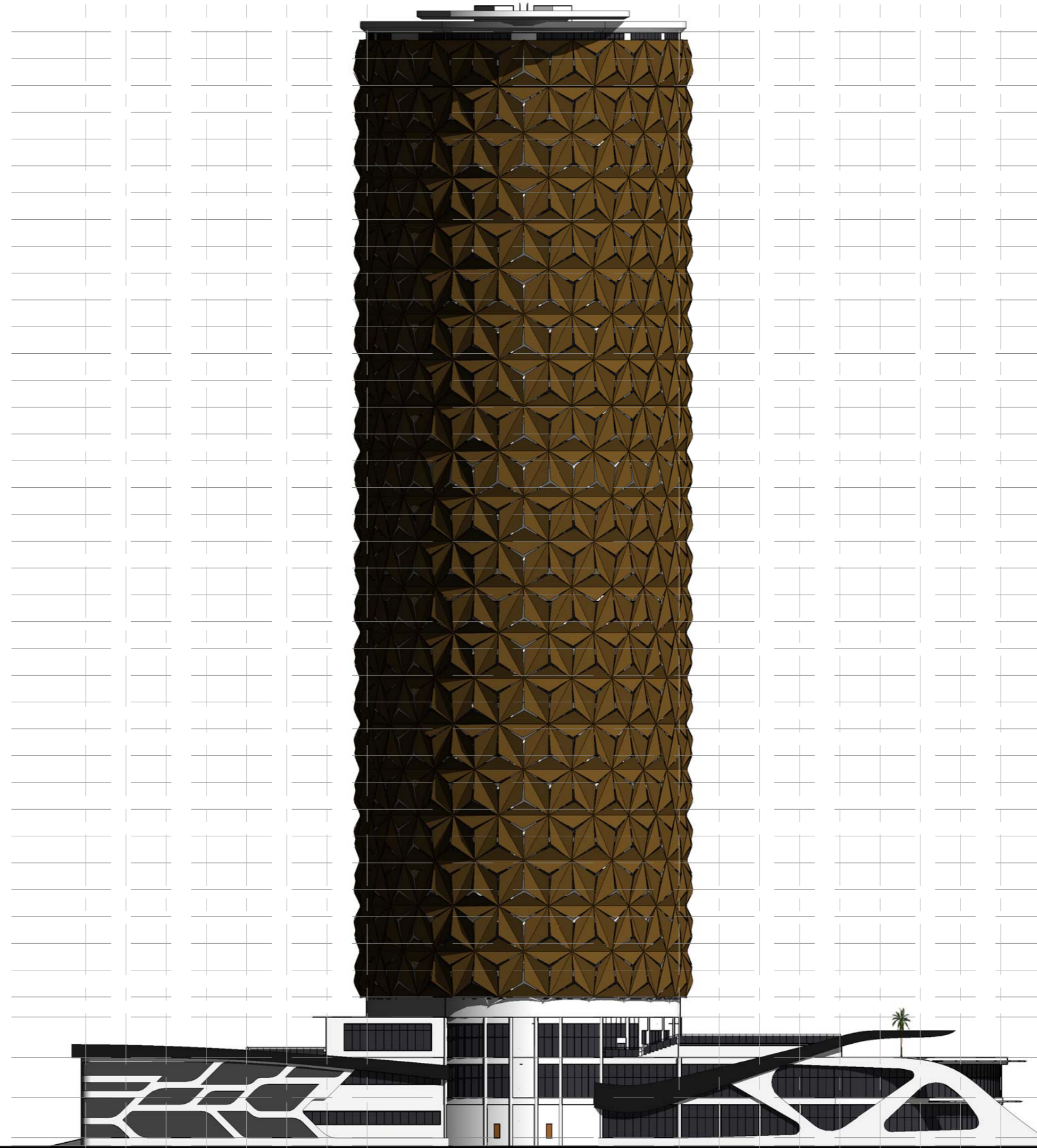

- 40 Roof Level 166200
- 39 Thirty Ninth Floor 162200
- 38 Thirty Eighth Floor 158200
- 37 Thirty Seventh Floor 154200
- 36 Thirty Sixth Floor 150200
- 35 Thirty Fifth Floor 146200
- 34 Thirty Fourth Floor 142200
- 33 Thirty Third Floor 138200
- 32 Thirty Second Floor 134200
- 31 Thirty First Floor 130200
- 30 Thirtieth Floor 126200
- 29 Twenty Ninth Floor 122200
- 28 Twenty Eighth Floor 118200
- 27 Twenty Seventh Floor 114200
- 26 Twenty Sixth Floor 110200
- 25 Twenty Fifth Floor 106200
- 24 Twenty Fourth Floor 102200
- 23 Twenty Third Floor 98200
- 22 Twenty Second Floor 94200
- 21 Twenty First Floor 90200
- 20 Twentieth Floor 86200
- 19 Nineteenth Floor 82200
- 18 Eighteenth Floor 78200
- 17 Seventeenth Floor 74200
- 16 Sixteenth Floor 70200
- 15 Fifteenth Floor 66200
- 14 Fourteenth Floor 62200
- 13 Thirteenth Floor 58200
- 12 Twelfth Floor 54200
- 11 Eleventh Floor 50200
- 10 Tenth Floor 46200
- 09 Ninth Floor 42200
- 08 Eighth Floor 38200
- 07 Seventh Floor 34200
- 06 Sixth Floor 30200
- 05 Fifth Floor 26200
- 04 Fourth Floor 22200
- 03 Third Floor 19200
- 02 Second Floor 13200
- 01 First Floor 7200
- 00 Ground Floor 1200

North Elevation

1 : 600

Meniru Emmanuel Chidiebube 199051003

MED 1 Architecture May , 2021

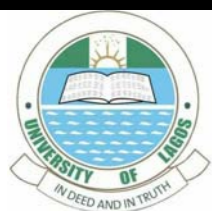

City Center 5 Star Hotel At Marina Lagos



ARC 801 Advanced Design Studio 1

CRITICS: Prof. Adebamowo, Dr. Adejumo, Dr. Obi, Dr. Jobi
Dr. Omoegun, Arc. Savage, Arc. Ajose-Adeogun
Arc. Williams

A B C D E F G H I J

K L M N O P Q R

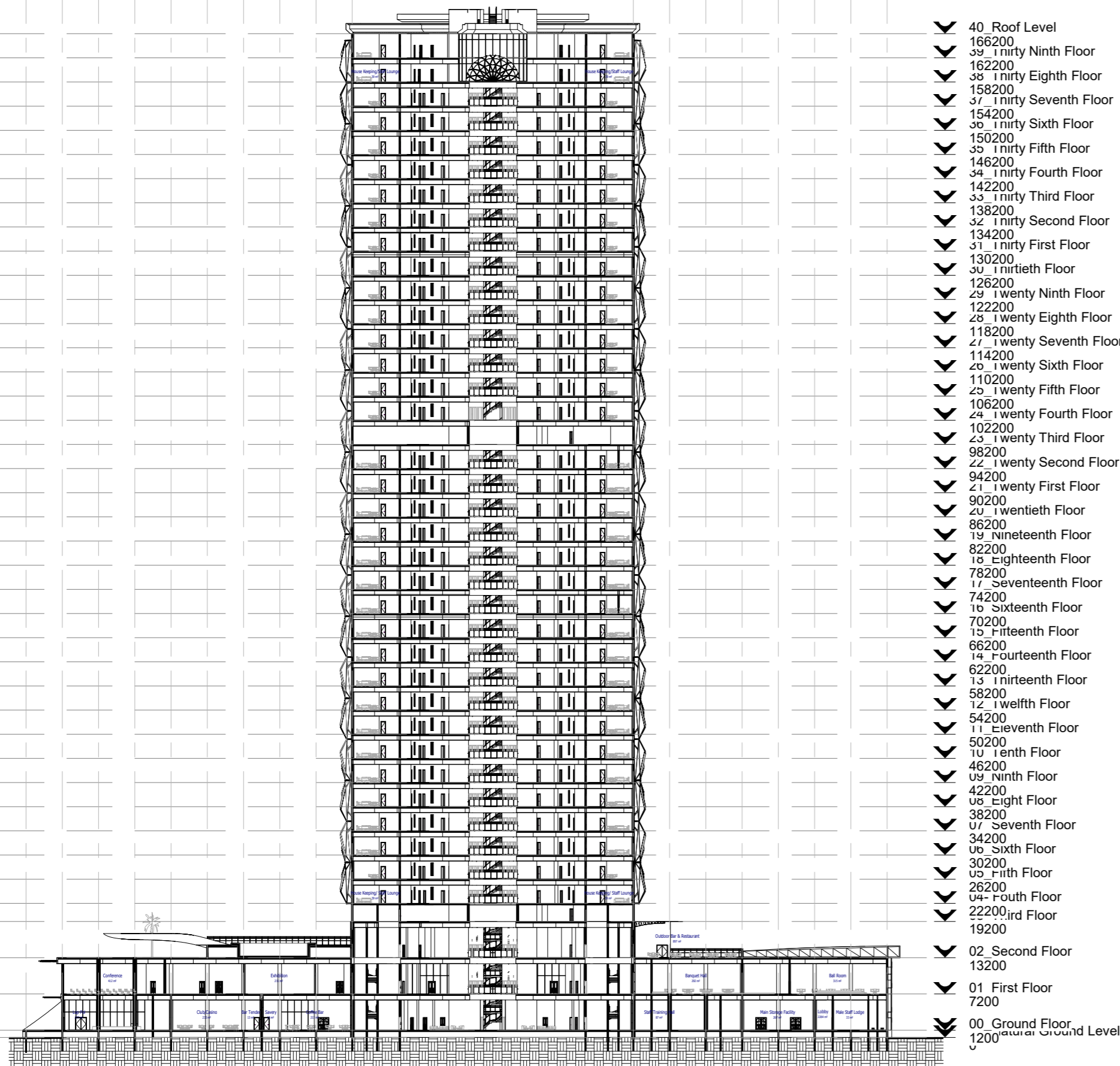

- 40 Roof Level 166200
- 39 Thirty Ninth Floor 162200
- 38 Thirty Eighth Floor 158200
- 37 Thirty Seventh Floor 154200
- 36 Thirty Sixth Floor 150200
- 35 Thirty Fifth Floor 146200
- 34 Thirty Fourth Floor 142200
- 33 Thirty Third Floor 138200
- 32 Thirty Second Floor 134200
- 31 Thirty First Floor 130200
- 30 Thirtieth Floor 126200
- 29 Twenty Ninth Floor 122200
- 28 Twenty Eighth Floor 118200
- 27 Twenty Seventh Floor 114200
- 26 Twenty Sixth Floor 110200
- 25 Twenty Fifth Floor 106200
- 24 Twenty Fourth Floor 102200
- 23 Twenty Third Floor 98200
- 22 Twenty Second Floor 94200
- 21 Twenty First Floor 90200
- 20 Twentieth Floor 86200
- 19 Nineteenth Floor 82200
- 18 Eighteenth Floor 78200
- 17 Seventeenth Floor 74200
- 16 Sixteenth Floor 70200
- 15 Fifteenth Floor 66200
- 14 Fourteenth Floor 62200
- 13 Thirteenth Floor 58200
- 12 Twelfth Floor 54200
- 11 Eleventh Floor 50200
- 10 Tenth Floor 46200
- 09 Ninth Floor 42200
- 08 Eighth Floor 38200
- 07 Seventh Floor 34200
- 06 Sixth Floor 30200
- 05 Fifth Floor 26200
- 04 Fourth Floor 22200
- 03 Third Floor 19200
- 02 Second Floor 13200
- 01 First Floor 7200
- 00 Ground Floor 1200
- 1200 Natural Ground Level

Section 1

1 : 750

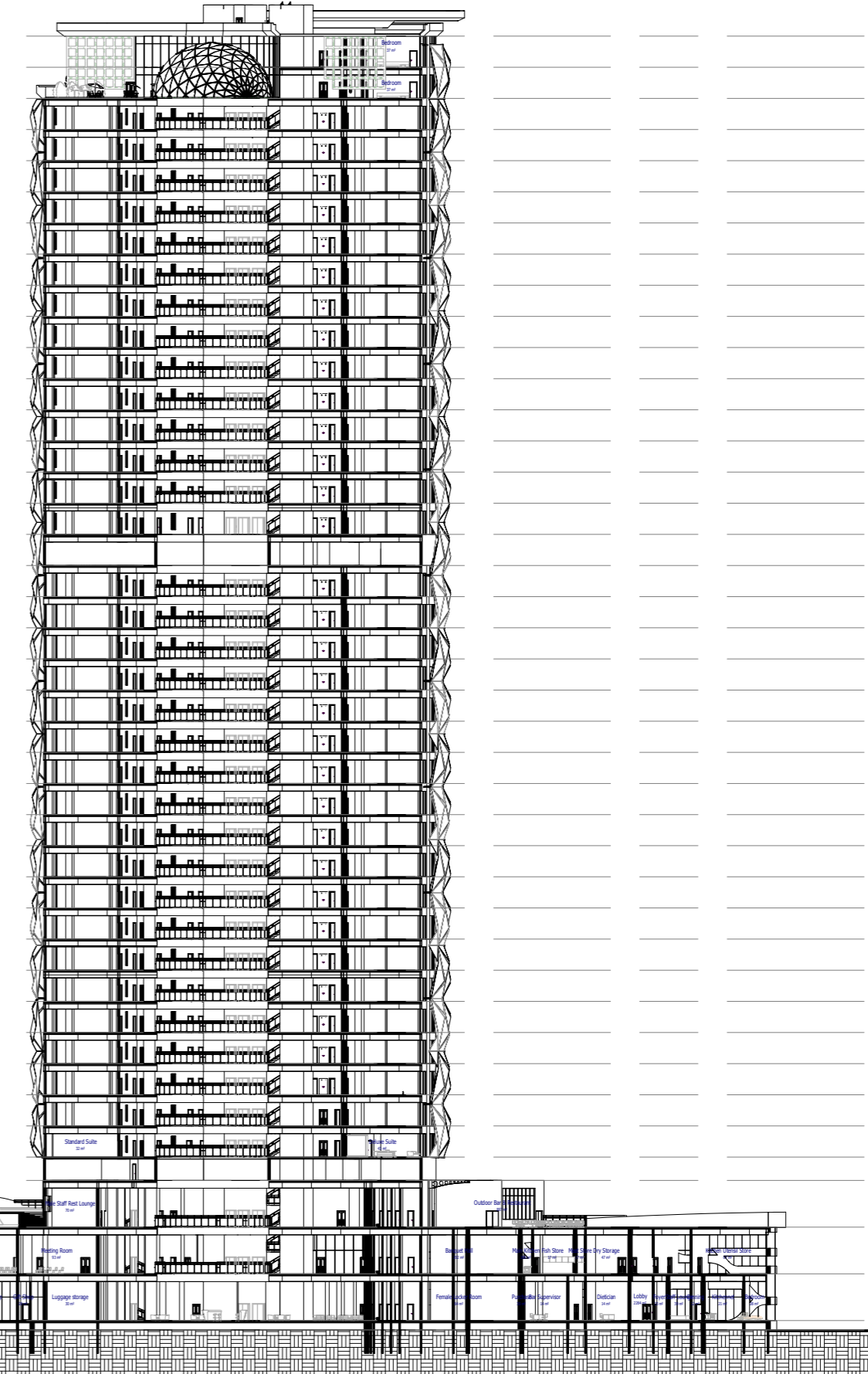

- 40 Roof Level 166200
- 39 Thirty Ninth Floor 162200
- 38 Thirty Eighth Floor 158200
- 37 Thirty Seventh Floor 154200
- 36 Thirty Sixth Floor 150200
- 35 Thirty Fifth Floor 146200
- 34 Thirty Fourth Floor 142200
- 33 Thirty Third Floor 138200
- 32 Thirty Second Floor 134200
- 31 Thirty First Floor 130200
- 30 Thirtieth Floor 126200
- 29 Twenty Ninth Floor 122200
- 28 Twenty Eighth Floor 118200
- 27 Twenty Seventh Floor 114200
- 26 Twenty Sixth Floor 110200
- 25 Twenty Fifth Floor 106200
- 24 Twenty Fourth Floor 102200
- 23 Twenty Third Floor 98200
- 22 Twenty Second Floor 94200
- 21 Twenty First Floor 90200
- 20 Twentieth Floor 86200
- 19 Nineteenth Floor 82200
- 18 Eighteenth Floor 78200
- 17 Seventeenth Floor 74200
- 16 Sixteenth Floor 70200
- 15 Fifteenth Floor 66200
- 14 Fourteenth Floor 62200
- 13 Thirteenth Floor 58200
- 12 Twelfth Floor 54200
- 11 Eleventh Floor 50200
- 10 Tenth Floor 46200
- 09 Ninth Floor 42200
- 08 Eighth Floor 38200
- 07 Seventh Floor 34200
- 06 Sixth Floor 30200
- 05 Fifth Floor 26200
- 04 Fourth Floor 22200
- 03 Third Floor 19200
- 02 Second Floor 13200
- 01 First Floor 7200
- 00 Ground Floor 1200
- 1200 Natural Ground Level

Section 2

1 : 750

Meniru Emmanuel Chidiebube 199051003

MED 1 Architecture May , 2021

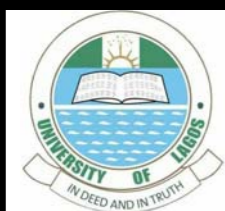

City Center 5 Star Hotel At Marina Lagos



ARC 801
Advanced Design Studio 1

CRITICS: Prof. Adebamowo, Dr. Adejumo, Dr. Obi, Dr. Jobi
Dr. Omoegun, Arc. Savage, Arc. Ajose-Adeogun
Arc. Williams

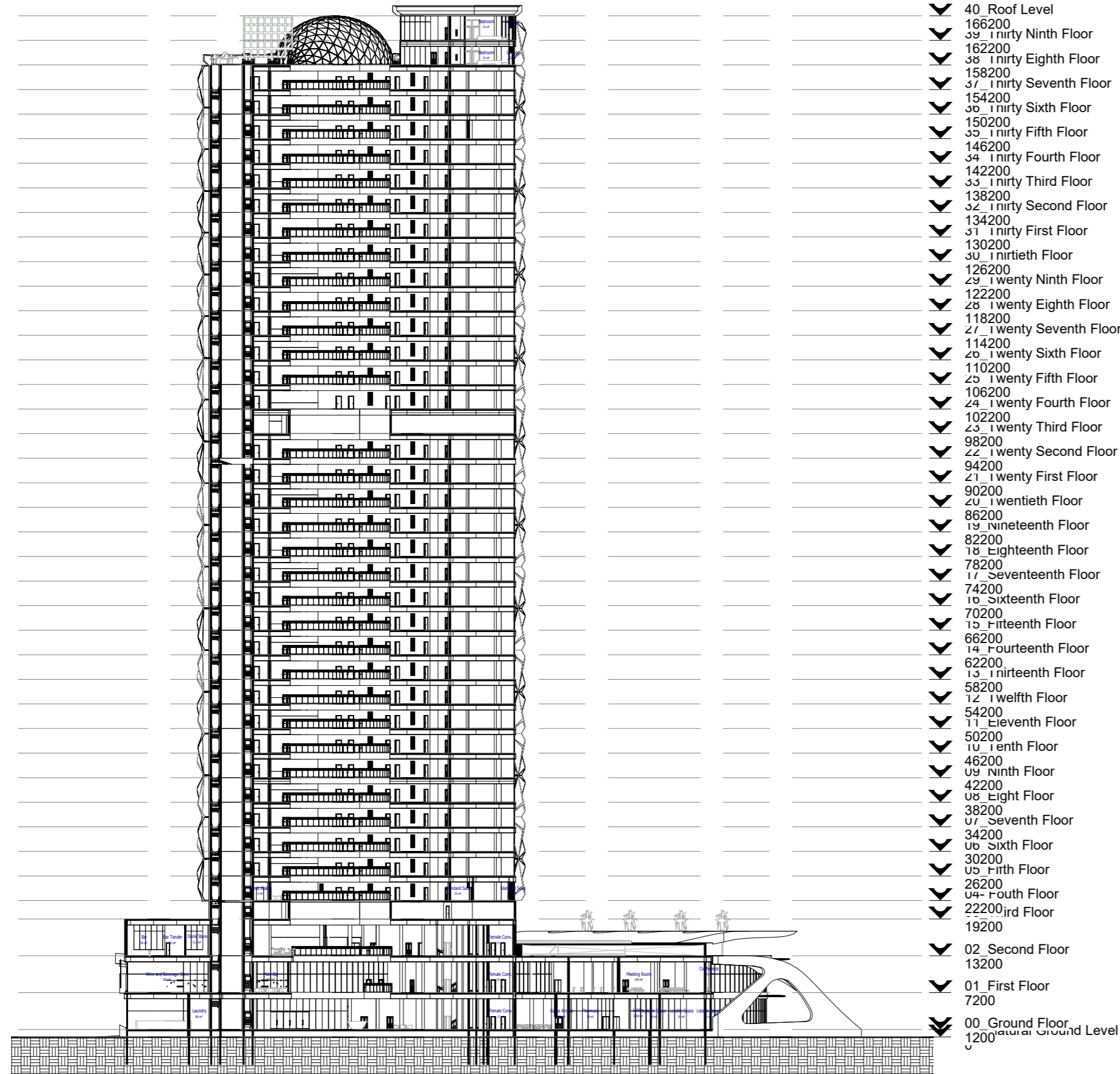

Section 3

1 : 750

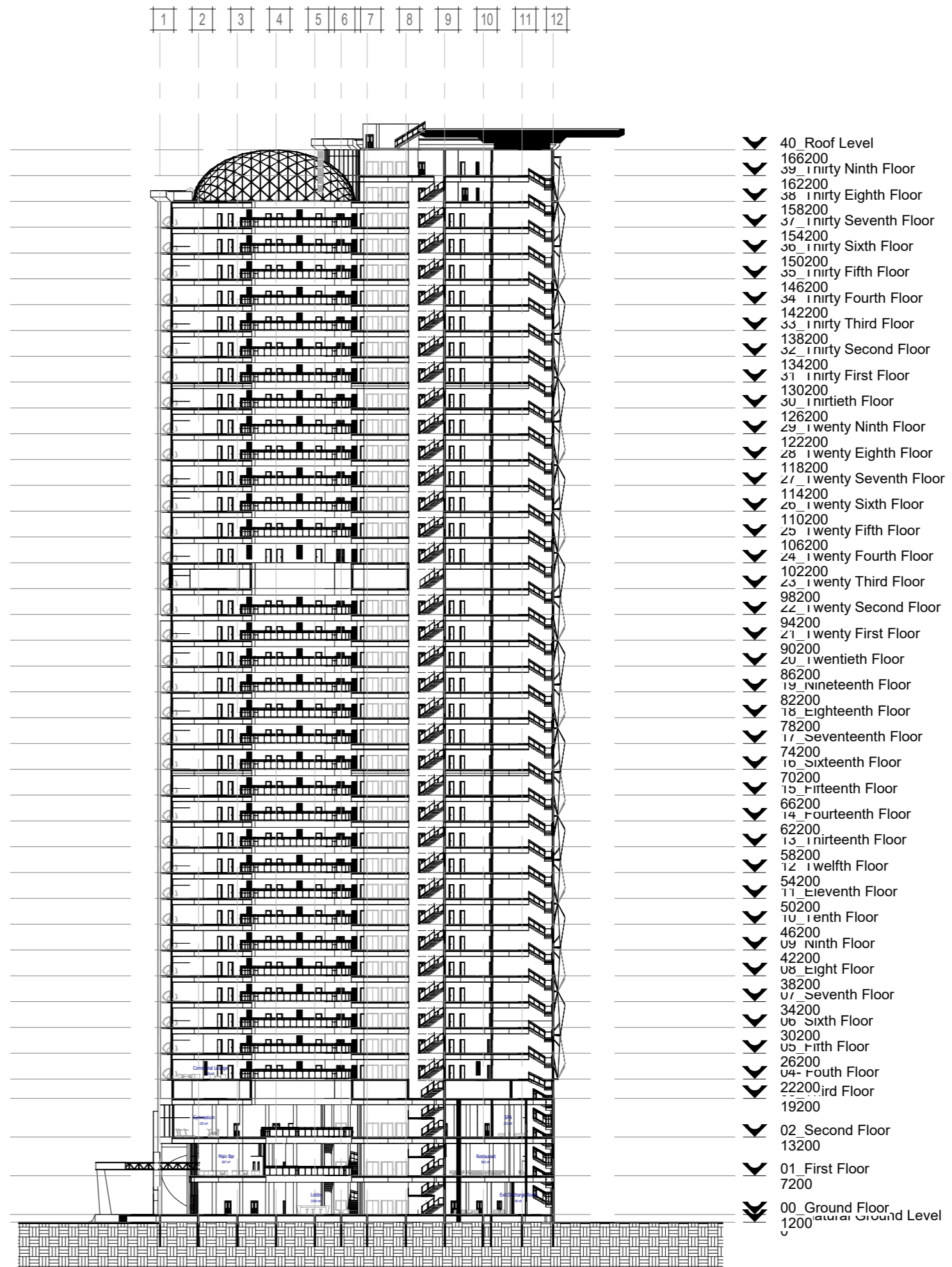

Section 4

1 : 750

Meniru Emmanuel Chidiebube 199051003

MED 1 Architecture May , 2021

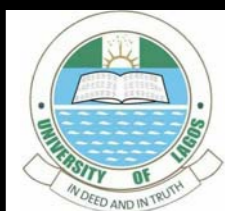

City Center 5 Star Hotel At Marina Lagos



ARC 801

Advanced Design Studio 1

CRITICS: Prof. Adebamowo, Dr. Adejumo, Dr. Obi, Dr. Jobi
Dr. Omoegun, Arc. Savage, Arc. Ajose-Adeogun
Arc. Williams

ROOM SCHEDULE		
ROOM CLASS	FLOOR LOCATION	NUMBER
STANDARD SUITE (Single)	4th to 22nd 24th to 37th	160
STANDARD SUITE (Double)	4th to 22nd 24th to 37th	160
DELUXE SUITE (Single)	4th to 22nd 24th to 37th	96
DELUXE SUITE (Double)	4th to 22nd 24th to 37th	96
EXECUTIVE SUITE	4th to 22nd 24th to 37th	64
RESIDENTIAL SUITE (Type A)	38th & 39th	2
RESIDENTIAL SUITE (Type B)	38th & 39th	4
PRESIDENTIAL SUITE	38th & 39th	1
TOTAL		583

Room Schedule 1

1 : 10

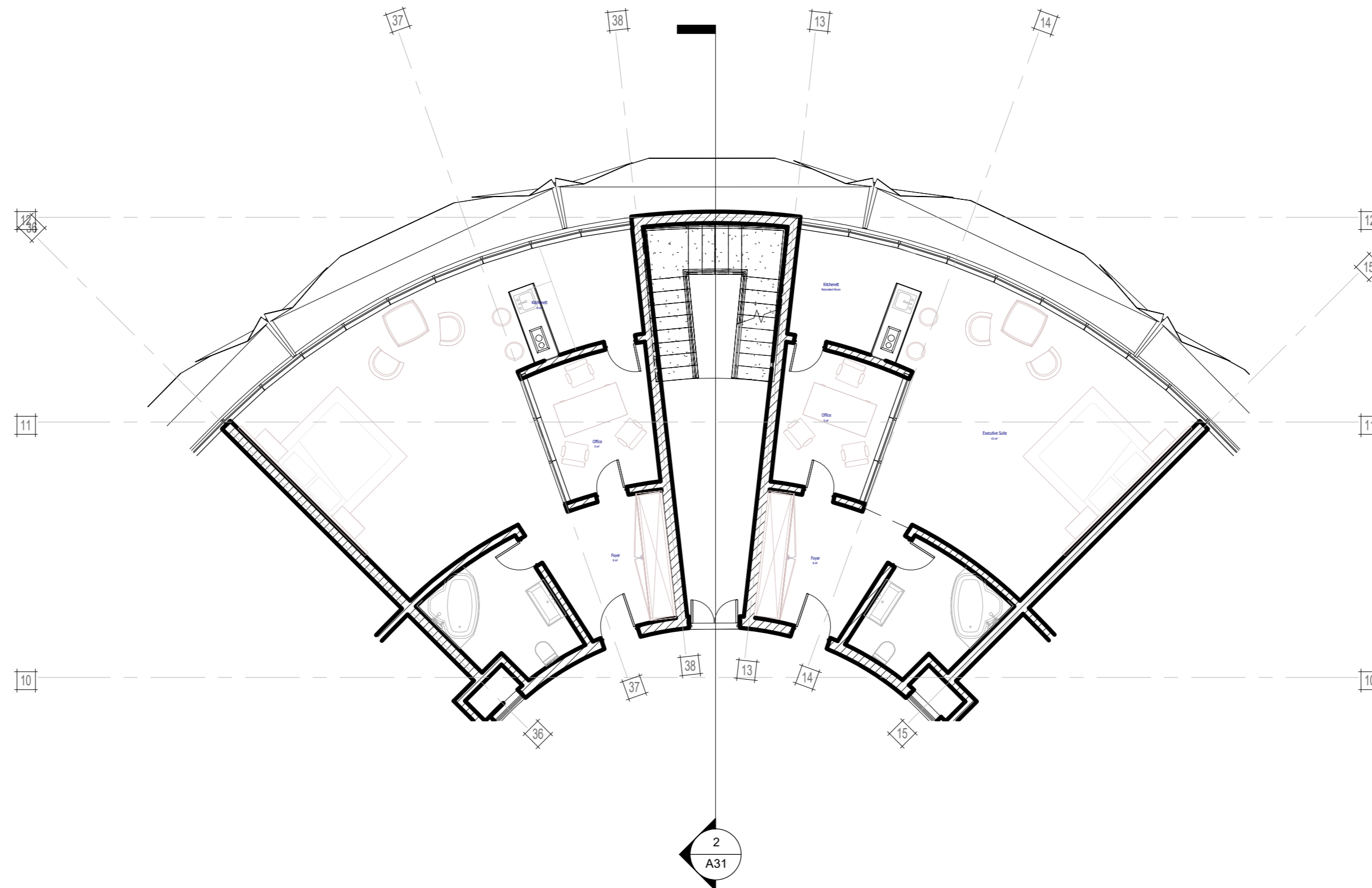

04_ Fouth to Thirthy Seventh Floor - Executive Suite

1 : 100

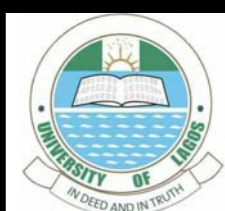

ROOM SCHEDULE		
ROOM CLASS	FLOOR LOCATION	NUMBER
STANDARD SUITE (Single)	4th to 22nd 24th to 37th	160
STANDARD SUITE (Double)	4th to 22nd 24th to 37th	160
DELUXE SUITE (Single)	4th to 22nd 24th to 37th	96
DELUXE SUITE (Double)	4th to 22nd 24th to 37th	96
EXECUTIVE SUITE	4th to 22nd 24th to 37th	64
RESIDENTIAL SUITE (Type A)	38th & 39th	2
RESIDENTIAL SUITE (Type B)	38th & 39th	4
PRESIDENTIAL SUITE	38th & 39th	1
TOTAL		583

Room Schedule 2

1 : 10

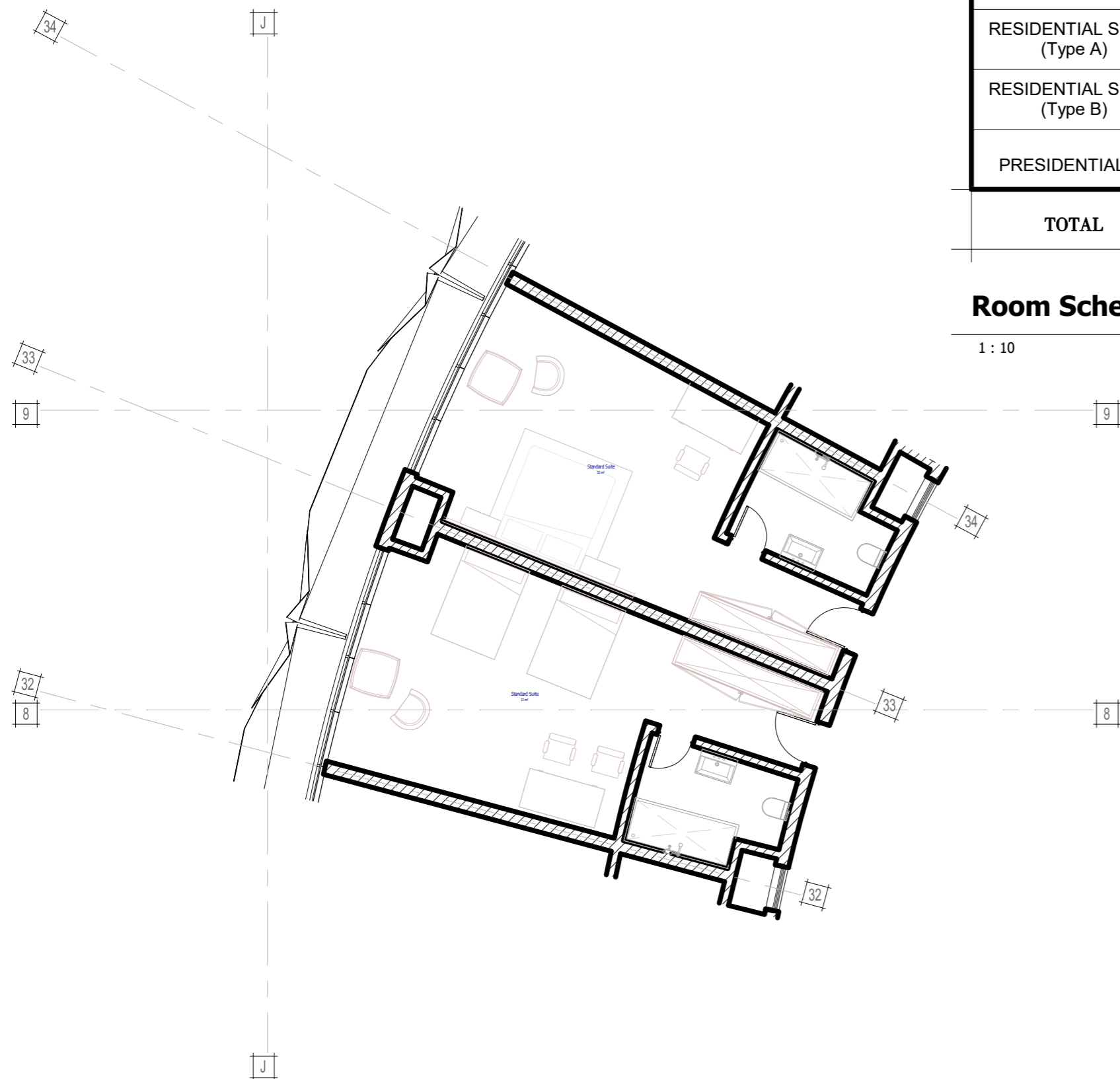

04_Fouth to Thirty Seventh Floor - Standard Suite_Single and Double

1 : 100

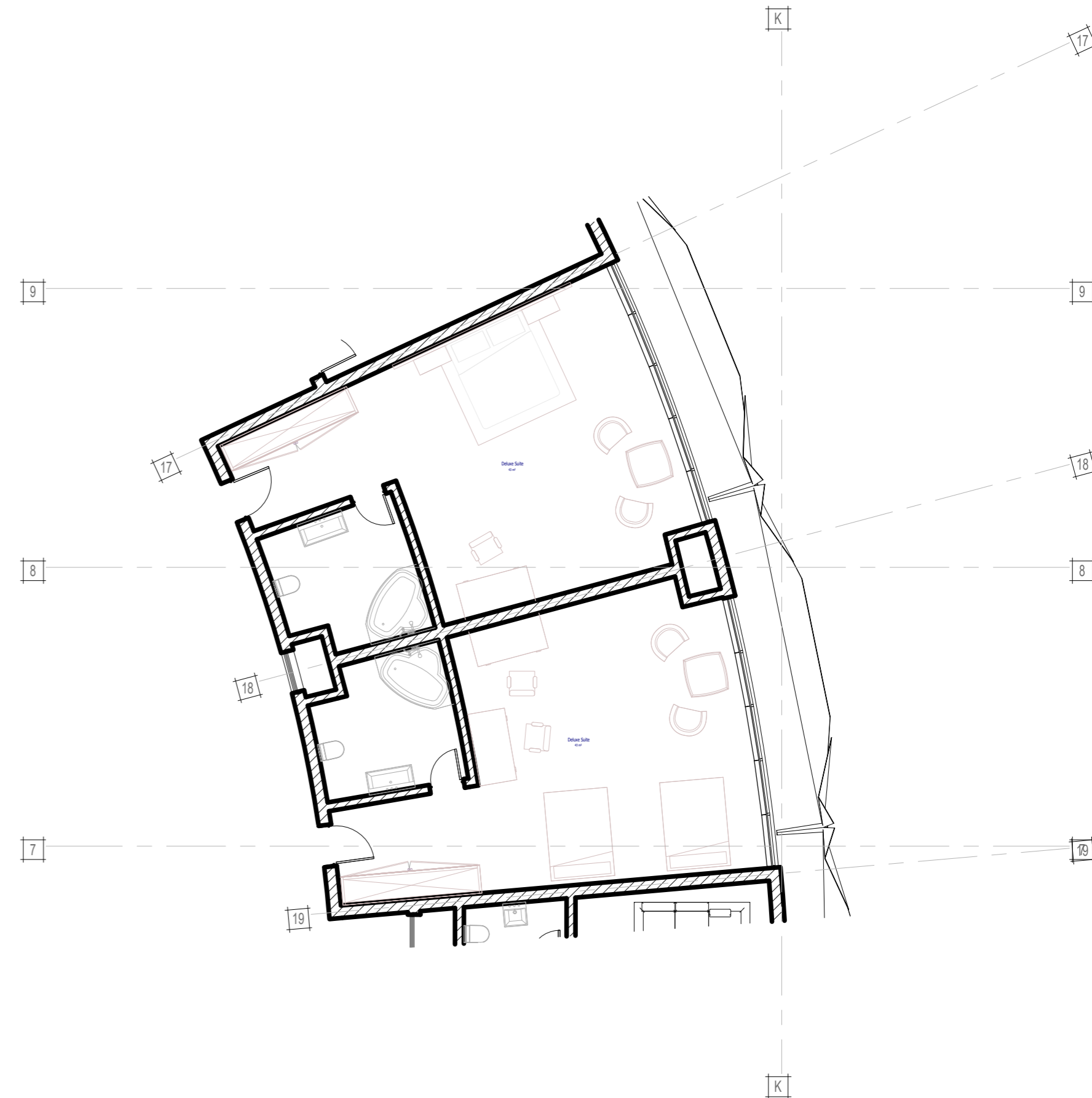

04_Fouth to Thirty Seventh Floor - Deluxe Suite_Single and Double

1 : 100

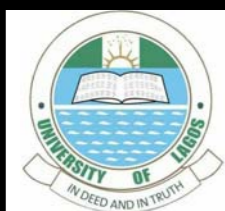

SCALE (@A2)
As indicated

ROOM SCHEDULE		
ROOM CLASS	FLOOR LOCATION	NUMBER
STANDARD SUITE (Single)	4th to 22nd 24th to 37th	160
STANDARD SUITE (Double)	4th to 22nd 24th to 37th	160
DELUXE SUITE (Single)	4th to 22nd 24th to 37th	96
DELUXE SUITE (Double)	4th to 22nd 24th to 37th	96
EXECUTIVE SUITE	4th to 22nd 24th to 37th	64
RESIDENTIAL SUITE (Type A)	38th & 39th	2
RESIDENTIAL SUITE (Type B)	38th & 39th	4
PRESIDENTIAL SUITE	38th & 39th	1
TOTAL		583

Room Schedule 3

1 : 10

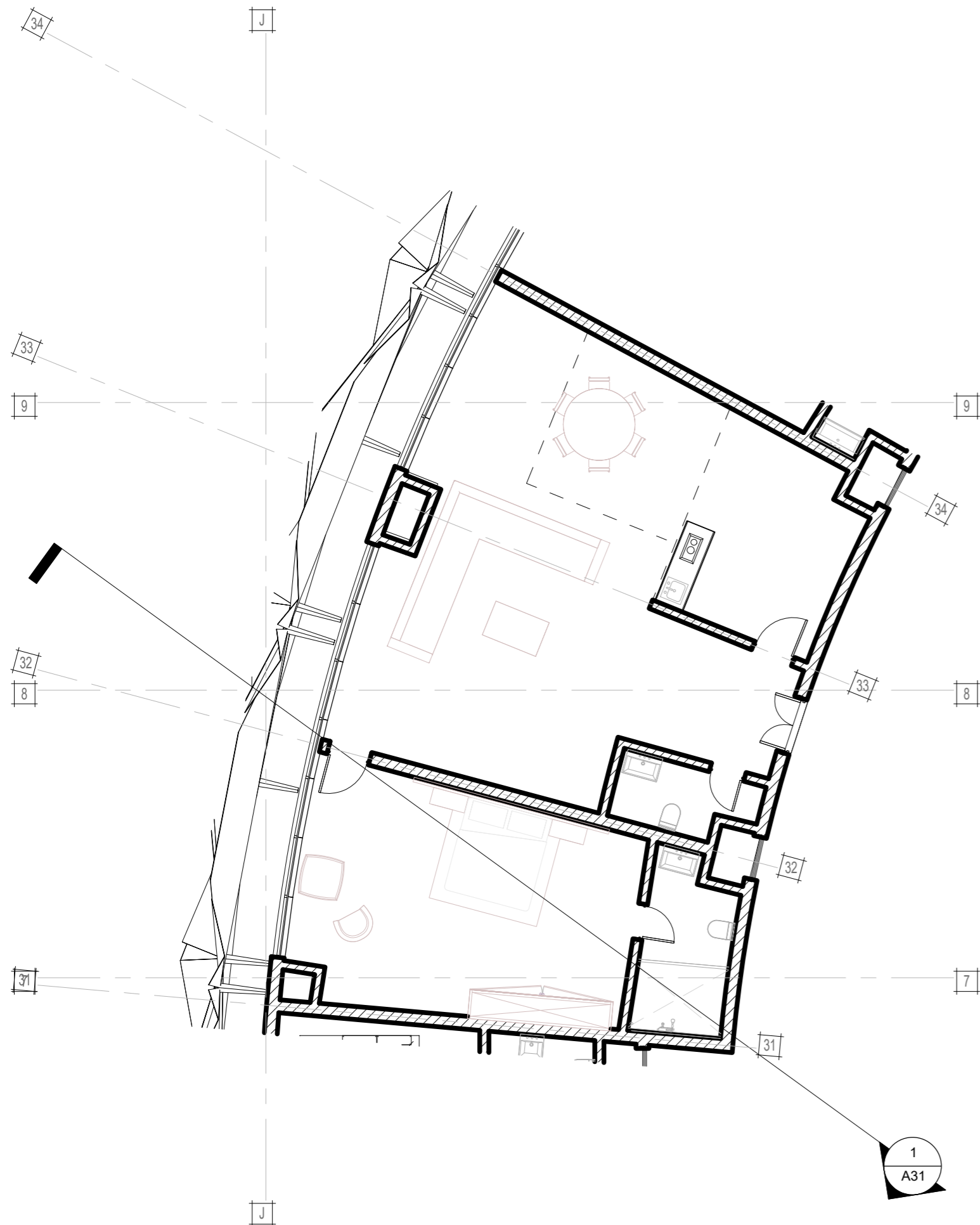

38_Thirty Eighth & Thirty Ninth Floor - One Bedroom Residential A

1 : 100

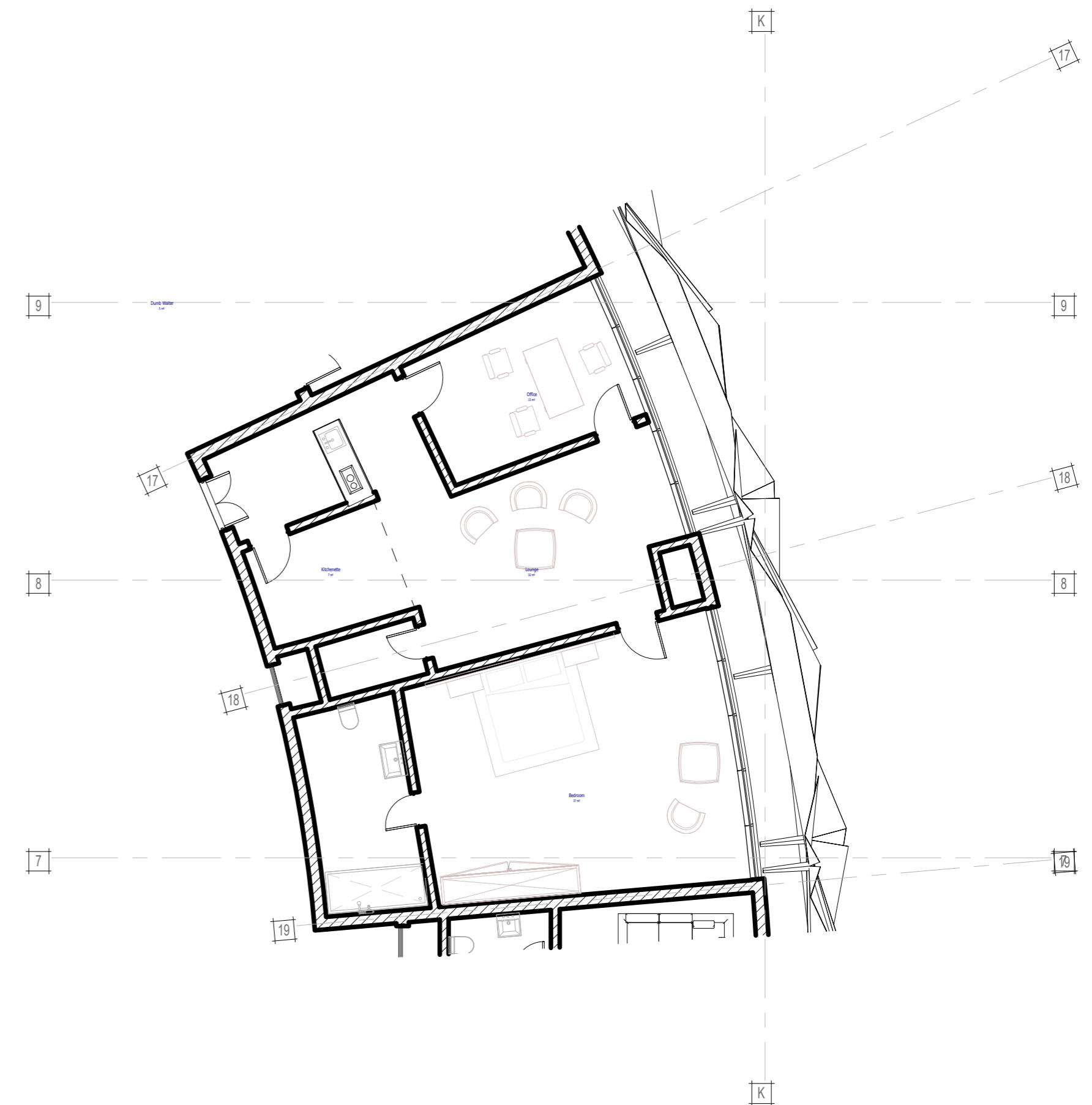

38_Thirty Eighth & Thirty Ninth Floor - One Bedroom Residential Suite B

1 : 100

Meniru Emmanuel Chidiebube 199051003

MED 1 Architecture May , 2021

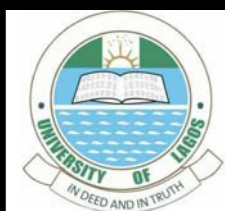

City Center 5 Star Hotel At Marina Lagos



ARC 801
Advanced Design Studio 1

CRITICS: Prof. Adebamowo, Dr. Adejumo, Dr. Obi, Dr. Jobi
Dr. Omoegun, Arc. Savage, Arc. Ajose-Adeogun
Arc. Williams

SCALE (@A2)
As indicated

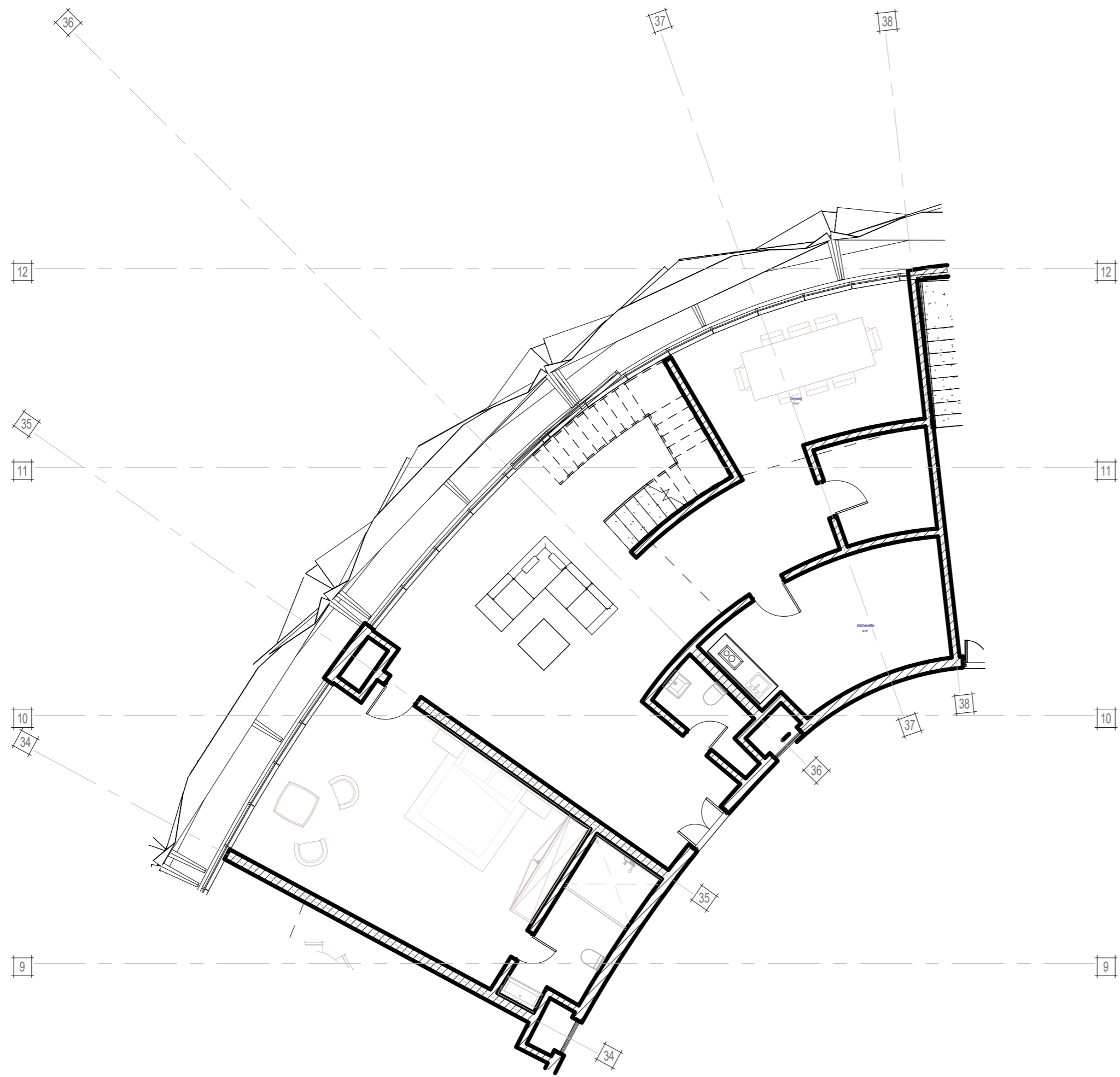

38_Thirty Eighth Floor - Presidential Suite

1 : 100

ROOM SCHEDULE		
ROOM CLASS	FLOOR LOCATION	NUMBER
STANDARD SUITE (Single)	4th to 22nd 24th to 37th	160
STANDARD SUITE (Double)	4th to 22nd 24th to 37th	160
DELUXE SUITE (Single)	4th to 22nd 24th to 37th	96
DELUXE SUITE (Double)	4th to 22nd 24th to 37th	96
EXECUTIVE SUITE	4th to 22nd 24th to 37th	64
RESIDENTIAL SUITE (Type A)	38th & 39th	2
RESIDENTIAL SUITE (Type B)	38th & 39th	4
PRESIDENTIAL SUITE	38th & 39th	1
TOTAL		583

Room Schedule 4

1 : 10

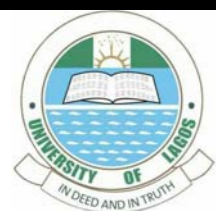

SCALE (@A2)
As indicated



39_Thirty Ninth Floor - Presidential Suite Cont.

1 : 100

ROOM SCHEDULE		
ROOM CLASS	FLOOR LOCATION	NUMBER
STANDARD SUITE (Single)	4th to 22nd 24th to 37th	160
STANDARD SUITE (Double)	4th to 22nd 24th to 37th	160
DELUXE SUITE (Single)	4th to 22nd 24th to 37th	96
DELUXE SUITE (Double)	4th to 22nd 24th to 37th	96
EXECUTIVE SUITE	4th to 22nd 24th to 37th	64
RESIDENTIAL SUITE (Type A)	38th & 39th	2
RESIDENTIAL SUITE (Type B)	38th & 39th	4
PRESIDENTIAL SUITE	38th & 39th	1
TOTAL		583

Room Schedule 5

1 : 10

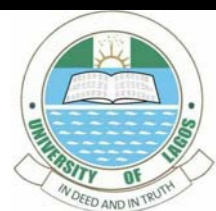

Kinetic Facade Cladding Detail

Details

A37

SCALE (@A2)

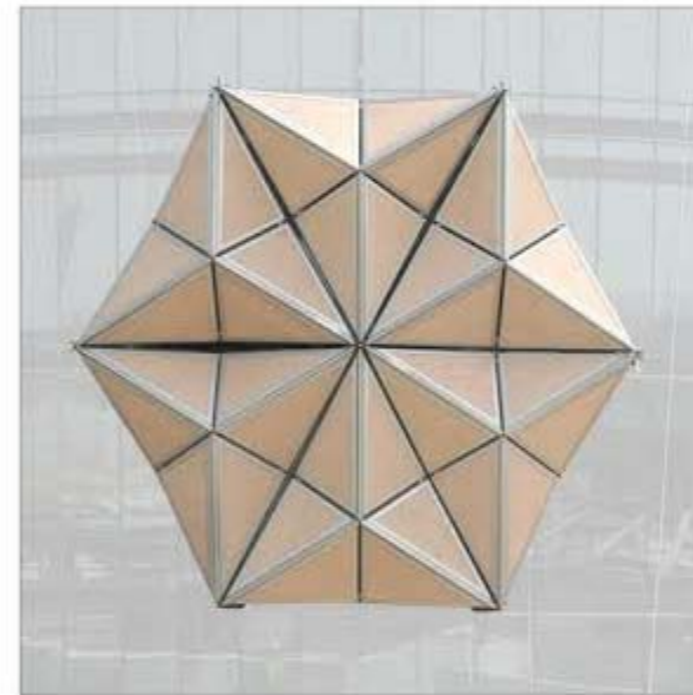
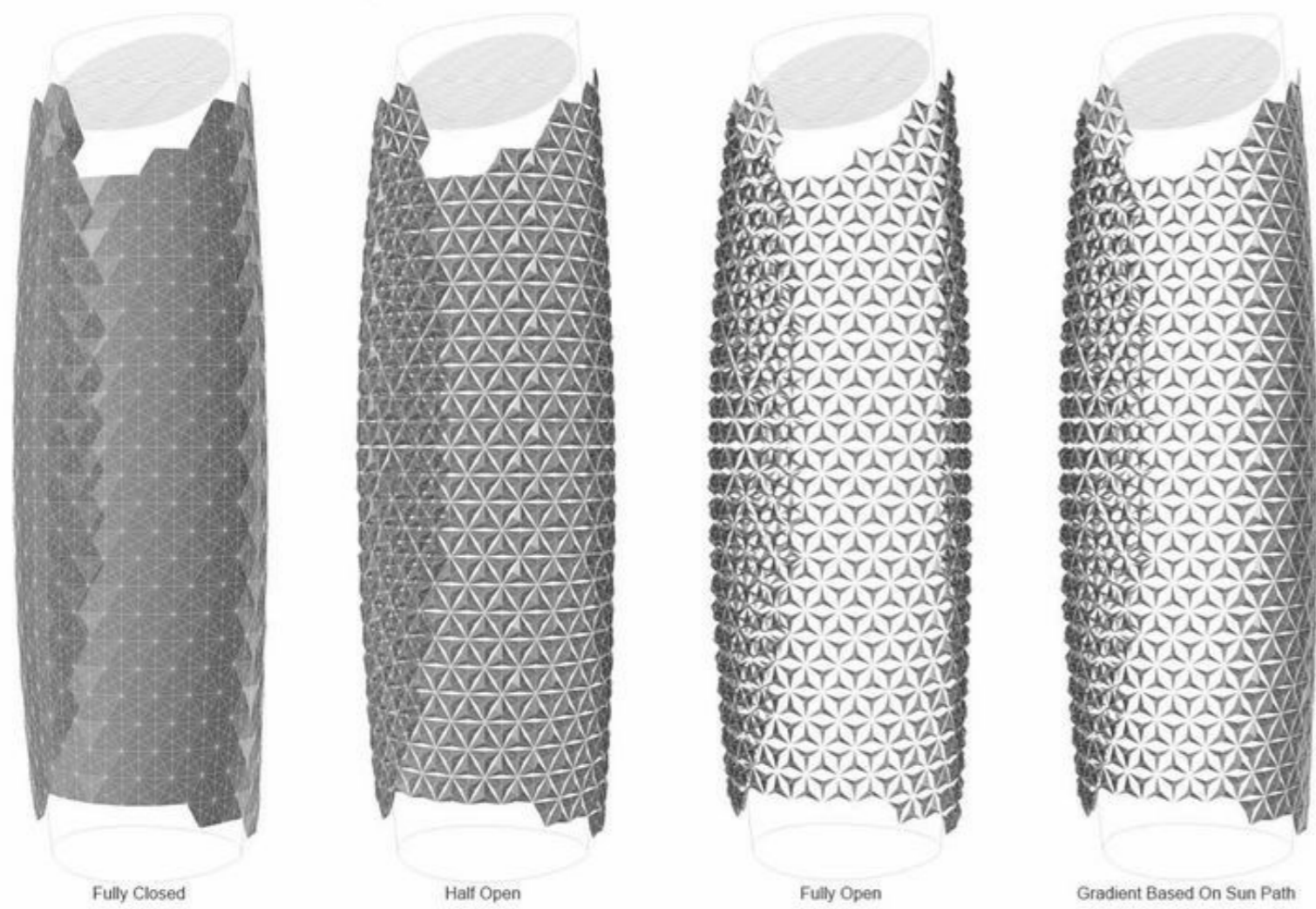

Fully Closed



Half Opened



Fully Open

Kinetic Facade Cladding controled manually and by Sun Path

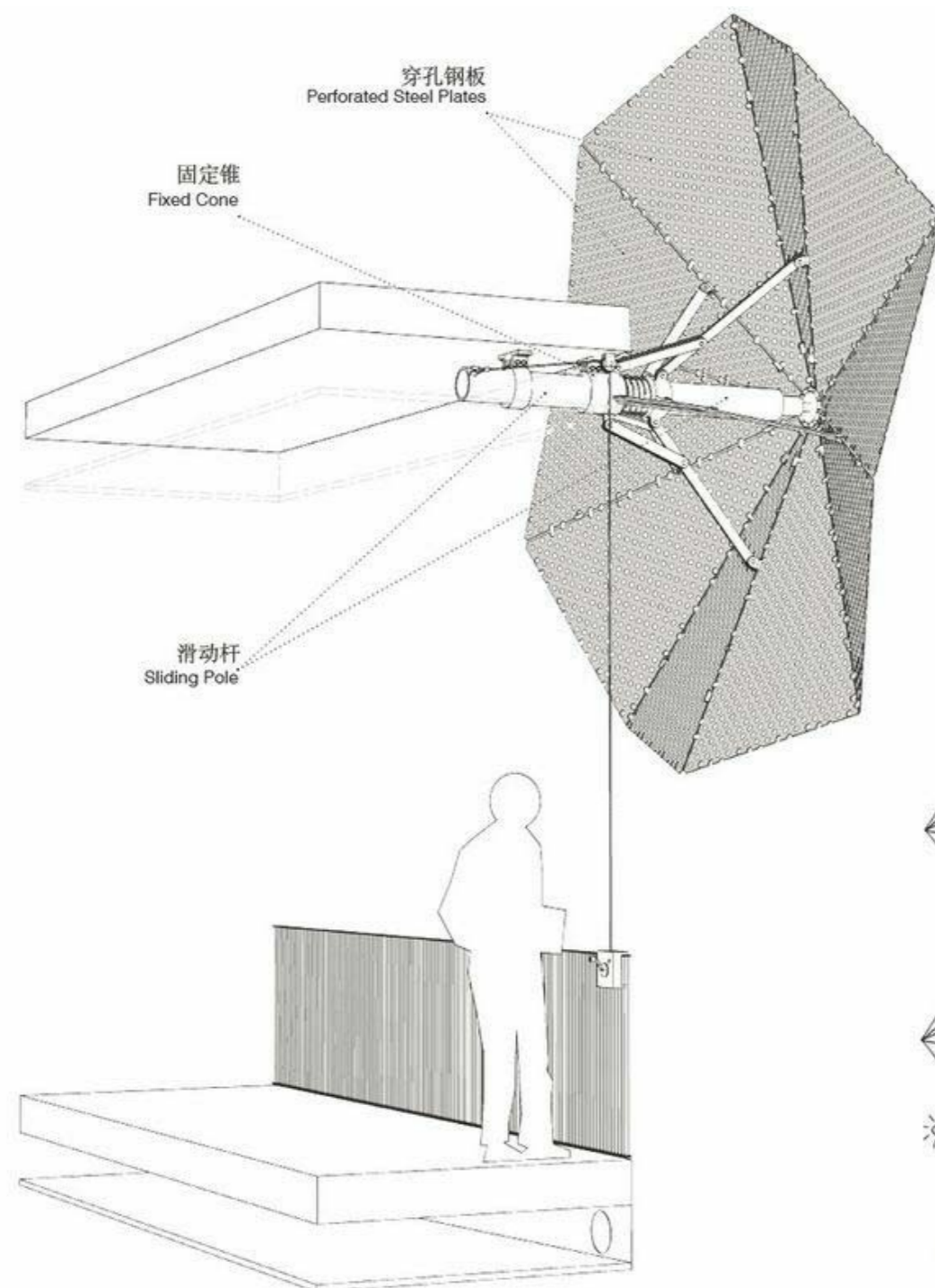

Umbrella Detail.

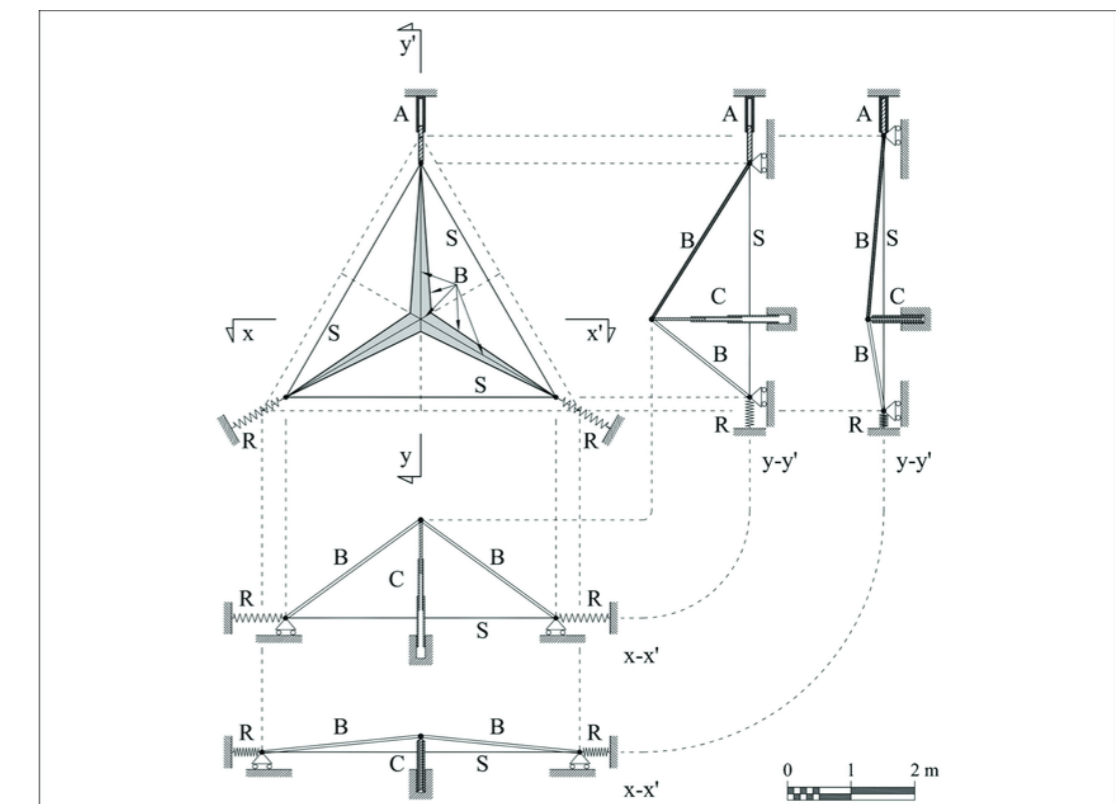
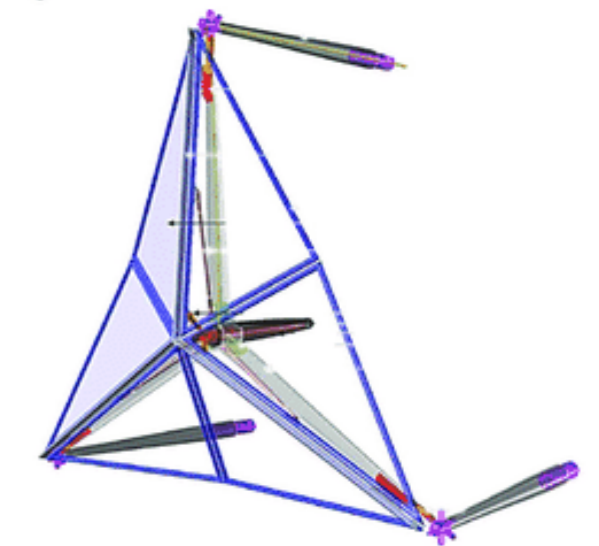
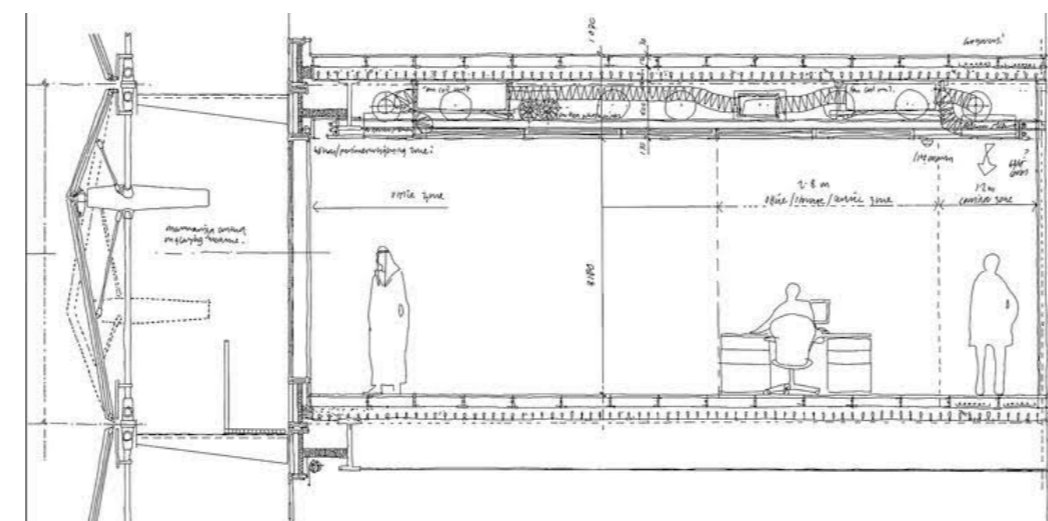
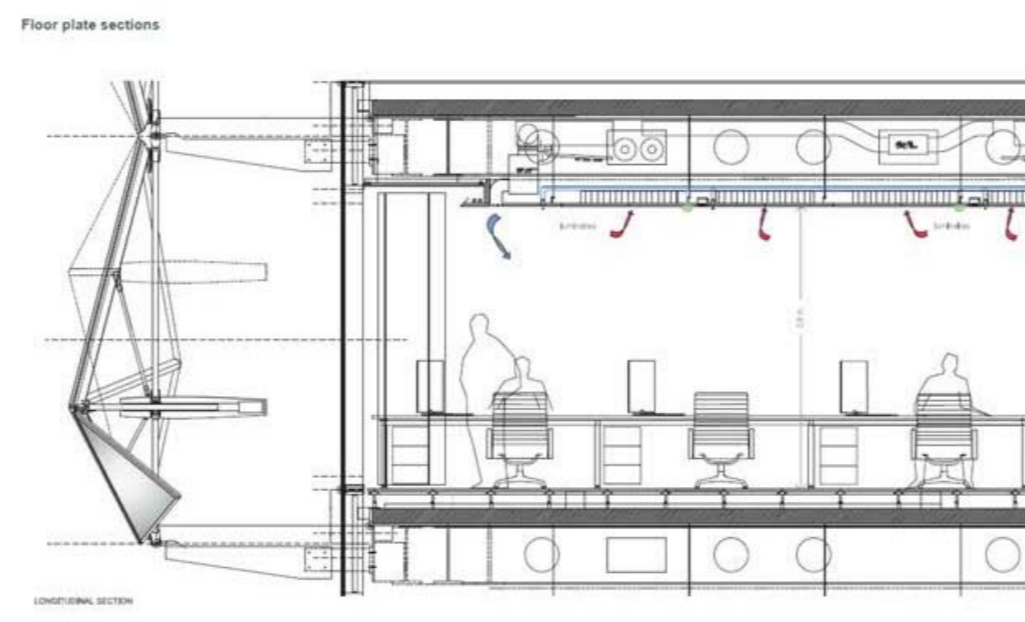

Meniru Emmanuel Chidiebube 199051003

MED 1 Architecture May , 2021

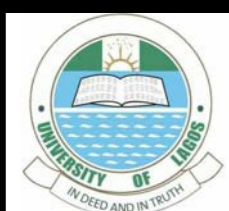

City Center 5 Star Hotel At Marina Lagos



ARC 801
Advanced Design Studio 1

CRITICS: Prof. Adebamowo, Dr. Adejumo, Dr. Obi, Dr. Jobi
Dr. Omoegun, Arc. Savage, Arc. Ajose-Adeogun
Arc. Williams

Roof Garden Detail A38

SCALE (@A2)

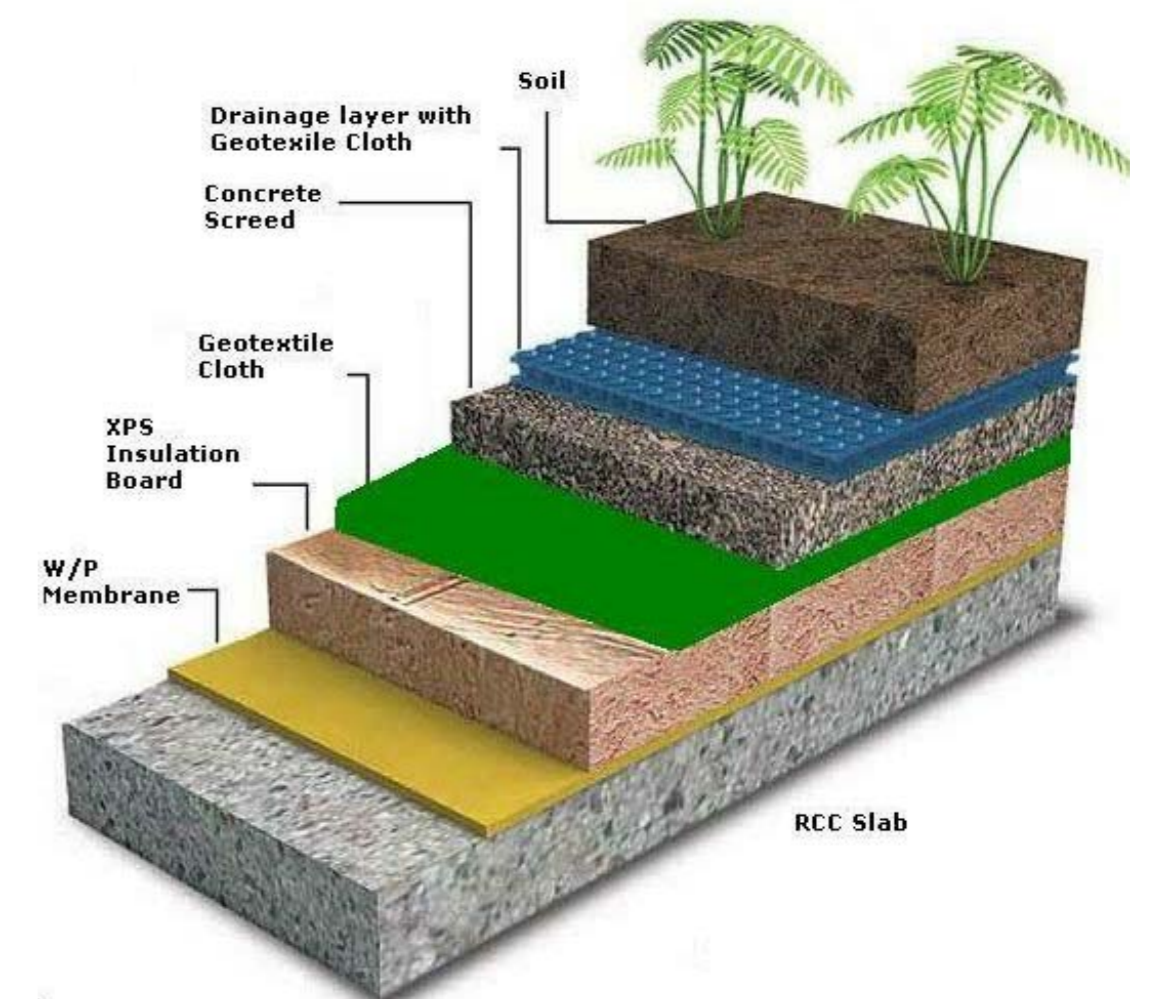
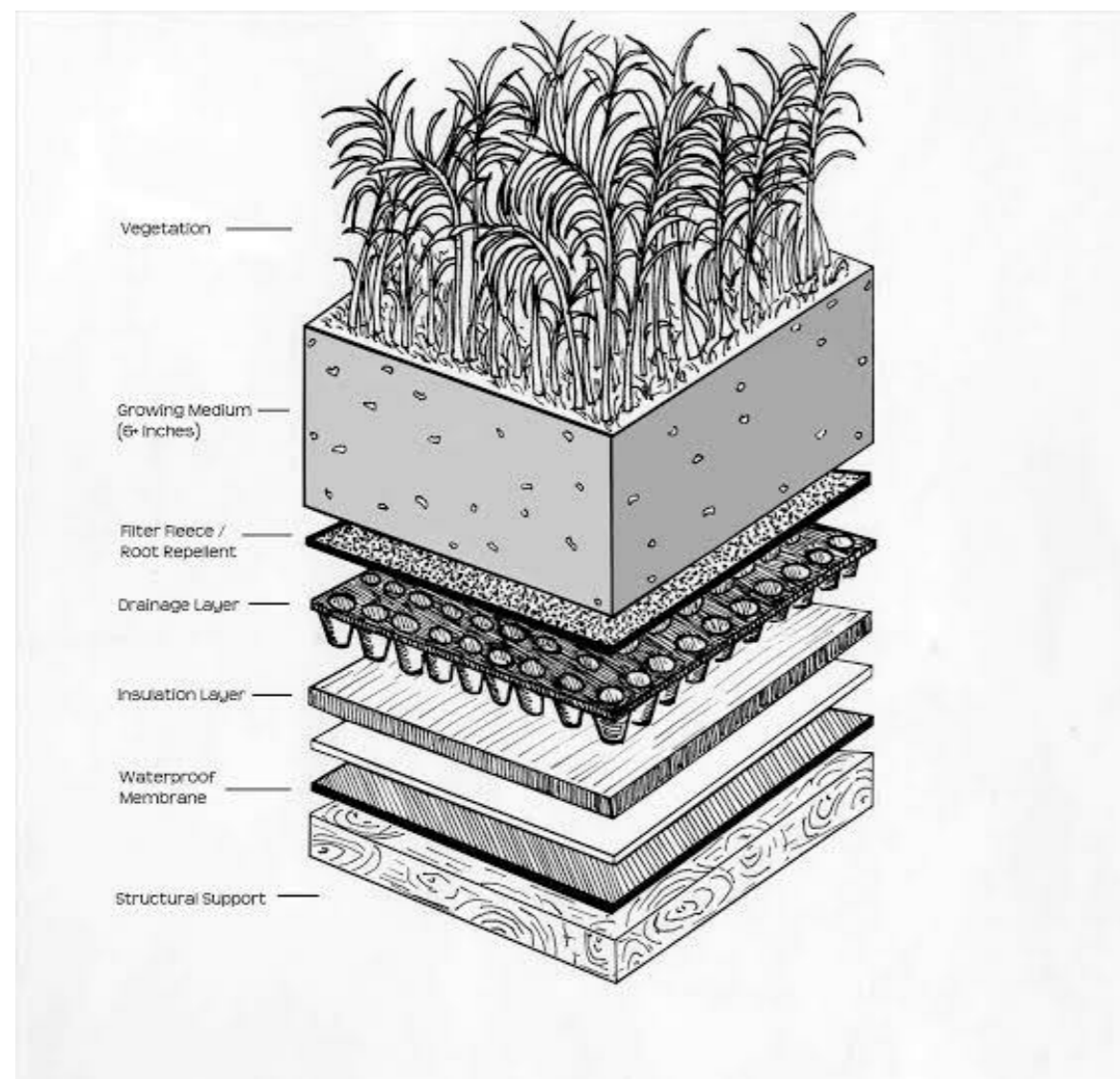
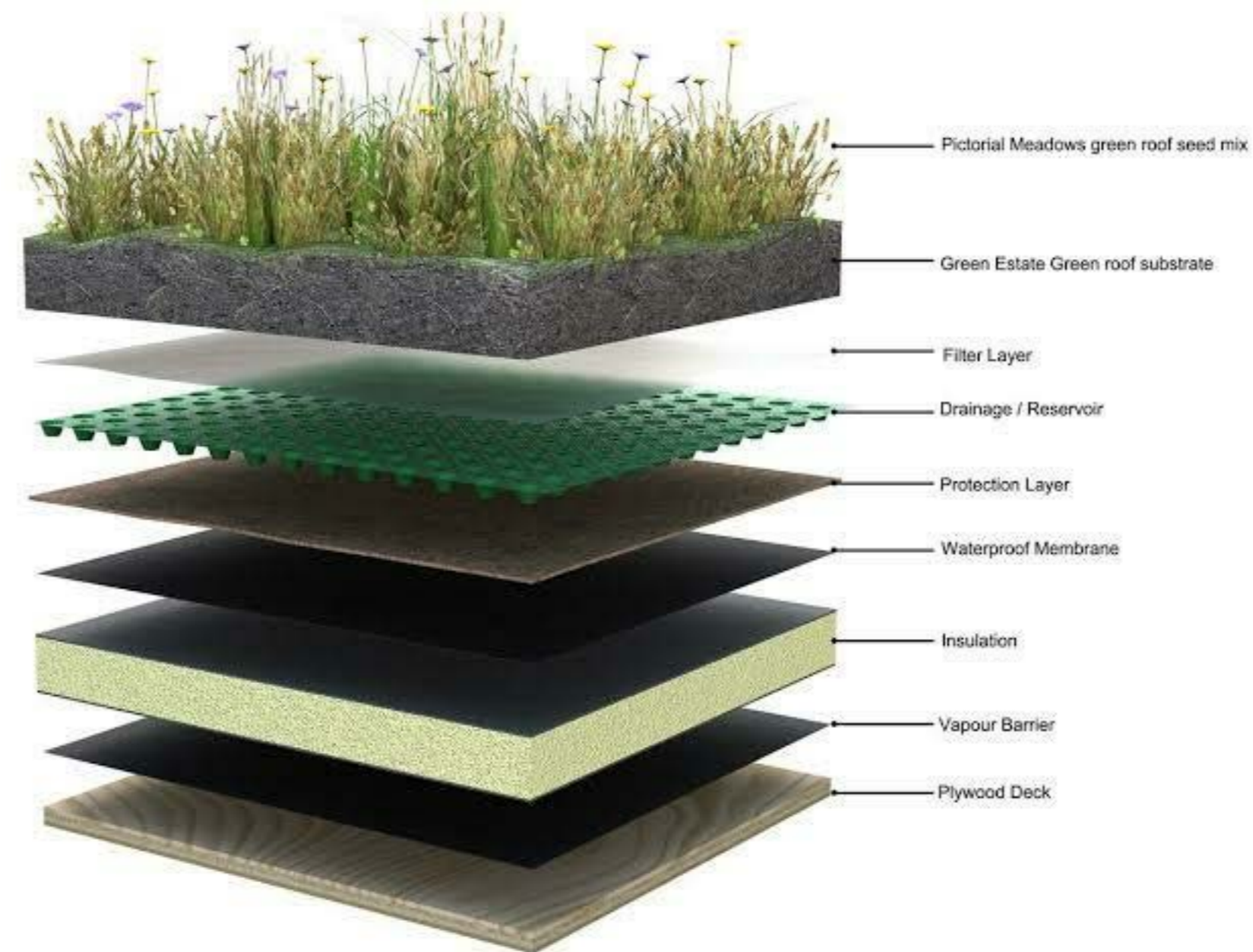

Meniru Emmanuel Chidiebube 199051003

MED 1 Architecture May , 2021

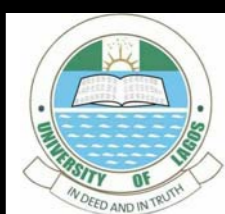

City Center 5 Star Hotel At Marina Lagos



ARC 801
Advanced Design Studio 1

CRITICS: Prof. Adebamowo, Dr. Adejumo, Dr. Obi, Dr. Jobi
Dr. Omoegun, Arc. Savage, Arc. Ajose-Adeogun
Arc. Williams